

USER MANUAL

DEMONSTRATION BOARD

DB-1



USER MANUAL

DEMONSTRATION BOARD DB-1



**SONEL S. A.
Wokulskiego 11
58-100 Świdnica
Poland**

Version 2.02 09.03.2026

CONTENTS

1	Safety	4
2	Application	5
3	The front panel	6
3.1	Arrangement of sockets and switches.....	6
3.2	Position of switches.....	7
4	Measurements	8
4.1	Measurement of the short circuit loop impedance	8
4.1.1	Measurement of the short circuit loop impedance in the L-PE circuit.....	8
4.1.2	Measurement of the short circuit loop impedance in the L-N circuit.....	10
4.2	Measurement of the parameters of the RCD switch.....	11
4.2.1	Realisation of measurements of the RCD switch parameters	11
4.3	Measurements of the earth resistance	13
4.3.1	Measurement of the earth electrode resistance using meters of the MRU series.....	14
a.	Earth resistance measurement R_E	14
b.	Earth resistance measurement R_{E1}	14
c.	Earth resistance measurement R_{E2} by means of the technical method.....	15
d.	Earth resistance measurement R_{E2} by means of the technical method using current clamp.....	15
e.	Earth resistance measurement R_{E2} by means of the two-clamp method	16
4.3.2	Measurement of the earth resistance using loop impedance meters	16
a.	Earth resistance measurement R_E	16
b.	Earth resistance measurement R_{E1}	17
c.	Earth resistance measurement R_{E2}	17
4.4	Earth resistivity measurements	18
4.5	Measurements of the continuity of equipotential bondings.....	19
4.5.1	Measurement of the resistance of the equipotential bonding between P1 and P2.....	19
4.5.2	Measurement of the resistance of equipotential bonding between P1 and P3	19
4.6	Insulation resistance measurement.....	20
4.6.1	Insulation resistance measurements in the L-N circuit.....	20
4.6.2	Insulation resistance measurements in the L-PE circuits.....	21
5	Replacement of fuses	21
6	Cleaning and maintenance	22
7	Dismantling and disposal	22
8	Technical specifications	22
9	Manufacturer	22

1 Safety

The DB-1 demonstration board has been designed for the purpose of simulation of measurements, whose results determine the safety conditions of a virtual installation. Therefore, in order to guarantee appropriate operation and correctness of the obtained results, the following recommendations must be followed:

- Before you proceed to operate the device read thoroughly the present manual and observe the safety regulations and instructions specified by the manufacturer.
- The device has been designed for operation at the nominal voltage of 220...240 V 50/60 Hz.
- The device cannot be used in the grid and with other devices in special interiors, for example those of a dangerous atmosphere regarding the risk of explosion or fire.
- It is unacceptable to operate the following:
 - ⇒ a damaged device which is completely or partially out of order
 - ⇒ a device with damaged power cable insulation,
 - ⇒ a device stored for an excessive period of time in disadvantageous conditions (e.g. excessive humidity). If the meter has been transferred from a cool to a warm environment of a high level of relative humidity, do not perform the measurements until the meter has been warmed up to the ambient temperature (approximately 30 minutes).
 - ⇒ a device with damaged housing.
- Before measurement of connection resistance or insulation resistance, make sure the measured object has been disconnected from the power supply. Disconnect the power cable of the device from the power supply contact and turn the RCD off.
- Repairs may be performed solely by an authorised service point. Before the device is connected to the power supply network, make sure the power supply socket is equipped with a properly connected earth pin. The board will not function if it is powered from a socket without an additional PE connection.
- The board is equipped with a protection constituted by two F 4A 250 V fuses (T 3,14A 250 V fuse are acceptable). The fuses are located in the device power supply socket. Should the fuse elements be damaged, they must be replaced.
- It is unacceptable to use other fuses.



WARNING

- **The DB-1 demonstration board may be used solely by qualified personnel who have appropriate certificates that entitle them to work on electric installations, or by persons working under their supervision. Using the board by unauthorised personnel or without supervision of such personnel may cause damage of the device and be a source of a serious danger for the user.**
- **Before the fuses are replaced, the device must be disconnected from the power supply network.**



NOTE!

- Before you proceed to operate the device, read thoroughly the present manual and observe the safety regulations and instructions specified by the manufacturer.
- The demonstration board has been designed for the purpose of simulation measurements of alternating voltage, impedance, short circuit, earth resistance, parameters of the RCD switch, ground resistivity, insulation resistance, resistance of equipotential bondings. Any application that differs from those specified in the present manual may cause damage of the device and be a source of a serious danger for the user.
- Before and during measurements of ground resistivity, insulation resistance, resistance of equipotential bondings, earth resistance (by means of the technical methods) disconnect the power cable of the device from the power supply socket and turn the RCD switch off. The power supply of the board is signalled by the „POWER ON“ diode.

2 Application

The DB-1 demonstration board is an indispensable element of training courses regarding realisation of electric measurements. It may be applied in schools, distribution centres of meters used in the power industry as well as in training centres.

The board may be used for the purpose of simulation of the following measurements:

- measurement of the short circuit loop impedance in the L-N circuit for the TT and TN networks,
- measurement of the short circuit loop impedance in the L-PE circuit for the TT and TN networks,
- measurement of the parameters of the RCD switch type AC,
- insulation resistance measurement in the L-N circuit,
- insulation resistance measurement in the L-PE circuit,
- measurement of the earth resistance by means of the technical method,
- earth resistance measurement using clamps,
- earth resistance measurement by means of the two-clamp method,
- earth resistance measurements by means of the impulse method,
- earth resistance measurements using meters for short-circuit loop measurements,
- resistivity measurements of three kinds of ground,
- measurement of the resistance of equipotential bondings,
- measurement of alternating voltage.

The demonstration board makes it possible to cause irregularities in the installation under scrutiny. This is possible thanks to the panel switches.

3 The front panel

3.1 Arrangement of sockets and switches

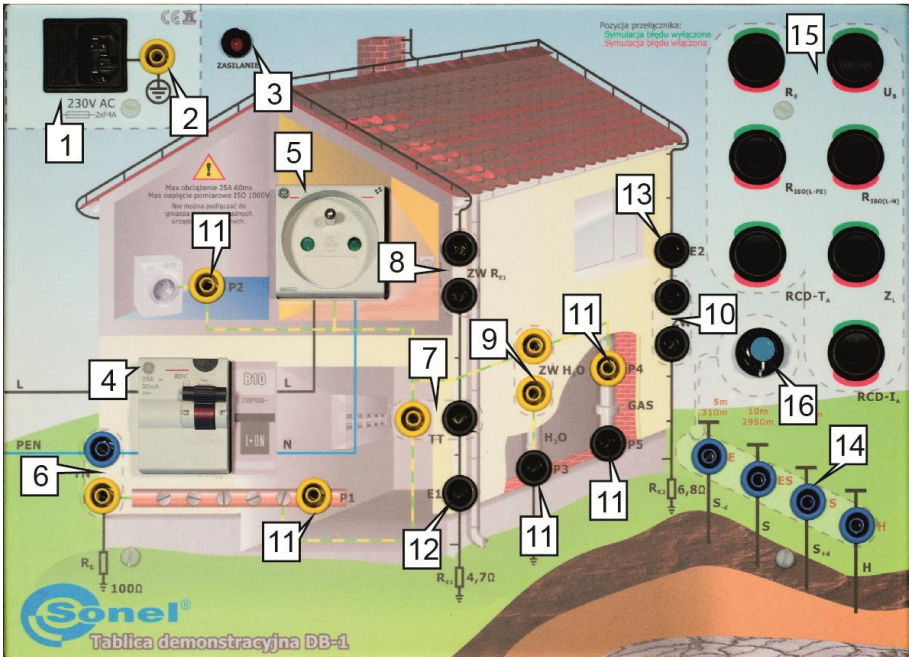

Fig. 1. Arrangements of the panel elements of the DB-1 demonstration board

- 1 Power supply network socket
- 2 Additional PE socket
- 3 Power supply signalling diode
- 4 RCD switch
- 5 Measurement socket
- 6 TN network jumper
- 7 TT network jumper
- 8 R_{E1} (Z_W R_{E1}) earth electrode jumper
- 9 Equipotential pipe connection jumper H₂O (Z_W H₂O)
- 10 R_{E2} (Z_W R_{E2}) earth electrode jumper
- 11 Measurement points P1, P2, P3, P4, P5
- 12 Measurement point of the R_{E1} (E1) earth electrode
- 13 Measurement point of the R_{E2} (E2) earth electrode
- 14 Measurement electrode sockets
- 15 Irregularity selection switches
- 16 Ground type switch for ground resistivity measurements

3.2 Position of switches

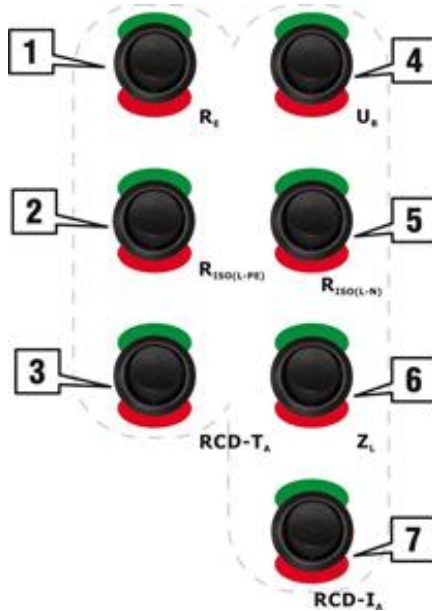

Fig. 2. Position of switches simulating irregularities in the electric installation of the measured object

- 1 R_E – high earth resistance at P2. $R_E = 1 \text{ k}\Omega$
- 2 U_B – the acceptable voltage value U_B has been exceeded during measurements of the RCD parameters in the measurement socket. $U_B > 25 \text{ V}$
- 3 $R_{ISO(L-PE)}$ – low insulation resistance – measurement L-PE. $R_{ISO(L-PE)} = 200 \text{ k}\Omega$
- 4 $R_{ISO(L-N)}$ – low insulation resistance – measurement L-N. $R_{ISO(L-N)} = 100 \text{ k}\Omega$
- 5 $RCD-T_A$ – the acceptable disconnection time of the RCD has been exceeded.
- 6 Z_L – high short circuit loop impedance. $Z_L \approx 6 \Omega$
- 7 $RCD-I_A$ – the activation current of the RCD is lower than the required value (damaged RCD or excessive leakage current of the installation). The leakage current of the installation $I_A \approx 15 \text{ mA}$

4 Measurements

4.1 Measurement of the short circuit loop impedance

A reliable and the most commonly used method of protection from electric shock consists in protection from indirect touch in circuits equipped with circuit breakers. The method consists in an automatic disconnection in the case of fault.

Conductive elements of the device are connected to the protective conductor of the power supply network. At the moment a hazardous touch voltage appears, which is caused by a metallic short circuit with the phase conductor of the power supply network, the current will flow in the phase – protective conductor circuit. The current is called short-circuit current. The passage of the short circuit current will cause activation of the circuit breakers and the power supply system will be turned off. The condition that must be met to have the protection level specified for the device as sufficient approved is that the elements must not be under a dangerous touch voltage for an excessive period of time. Therefore the safety device must respond quickly, and within the period of time specified in the relevant norms. The condition of appropriate protection may be expressed by the following equation:

$$Z_S \leq \frac{U_0}{I_A}$$

Z_S – short circuit loop impedance
 I_A – current activating the circuit breaker within the required period of time
 U_0 – power supply network nominal voltage in relation to earth

4.1.1 Measurement of the short circuit loop impedance in the L-PE circuit

Measurement of the short circuit loop impedance in the L-PE circuit may be performed using the MPI-5XX meter in the $Z_{L-PE[RCD]}$ function. Should another meter or function be used, the RCD switch of the demonstration board may be triggered.

In order to perform the measurement proceed as follows:

- connect the power supply network cable to the socket of the demonstration board,
- select the kind of TT or TN network using a jumper in the appropriate position (Figure 3),
- all the switches simulating irregularities must be in the „green” position,
- turn the RCD switch on,
- connect the meter to the power network socket of the board using leads, in accordance with Figure 4,
- perform the measurement

The demonstration board permits to perform measurements of a short circuit loop, whose value may be artificially overstated (simulation of irregularities). In order to do so, before you proceed to perform the measurement place the Z_L switch in the „red” position. Having finished the measurement, place the Z_L switch again in the „green” position.

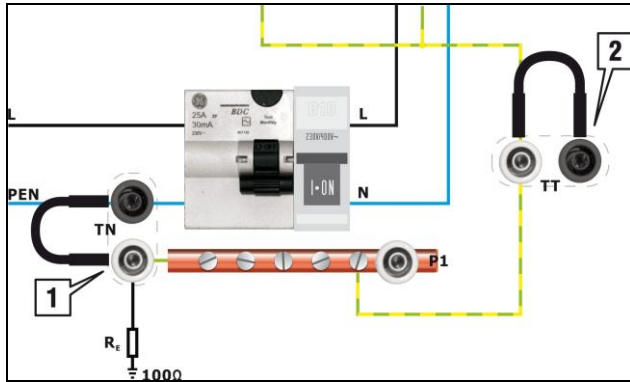

Fig. 3. Network type selection jumpers.
1 - jumper simulating measurements in the TN network,
2 - jumper placed simulating measurements in the TT network

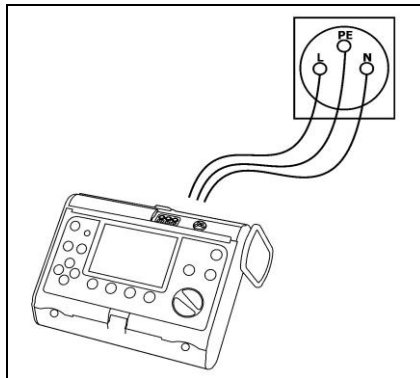

Fig. 4. Connection of the meter

Expected results

- Switch **Z_L „green”** for the TN network (**TN jumper**): $Z_{L-PE} = Z_{L-N}$ of the network + 1.4 Ω
- Switch **Z_L „red”** for the TN network (**TN jumper**): $Z_{L-PE} = Z_{L-N}$ of the network + 5.5 Ω
- Switch **Z_L „green”** for the TT network (**TT jumper**): $Z_{L-PE} = Z_{L-N}$ of the network + 5.5 Ω
- Switch **Z_L „red”** for the TT network (**TT jumper**): $Z_{L-PE} = Z_{L-N}$ of the network + 10 Ω

Z_{L-N} of the network – the network impedance in the L-N circuit of the socket to which the demonstration board cable is connected.

4.1.2 Measurement of the short circuit loop impedance in the L-N circuit

Measurements may be performed with any meter for measurements of the short circuit loop whose short circuit current does not exceed 25 A, and whose measurement time does not exceed 60 ms, e.g. MZC-30X, MZC-20X, MPI-5XX.

In order to perform the measurement proceed as follows:

- connect the power supply network cable to the socket of the demonstration board,
- select the kind of network, **TT** or **TN**, using the jumper in the appropriate position (Fig. 3),
- all the switches simulating irregularities must be in the „green” position,
- turn the RCD switch on,
- connect the meter to the power network socket of the board using leads, in accordance with Figure 4,
- perform the measurement.

The demonstration board permits to perform measurements of a short circuit loop, whose value may be artificially overstated (simulation of irregularities). In order to do so, before you proceed to perform the measurement place the Z_L switch in the „red” position. Having finished the measurement, place the Z_L switch again in the „green” position.

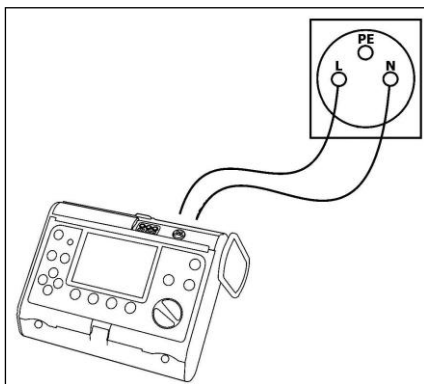

Fig. 5. Connection of the meter

Expected results

- Switch Z_L „green” for the TN network (**TN jumper**): $Z_{L-N} = Z_{L-N}$ of the network + 1.1 Ω
- Switch Z_L „red” for the TN network (**TN jumper**): $Z_{L-N} = Z_{L-N}$ of the network + 5.5 Ω
- Switch Z_L „green” for the TT network (**TT jumper**): $Z_{L-N} = Z_{L-N}$ of the network + 1.1 Ω
- Switch Z_L „red” for the TT network (**TT jumper**): $Z_{L-N} = Z_{L-N}$ of the network + 5.5 Ω

Z_{L-N} of the network – the network impedance in the L-N circuit of the socket to which the demonstration board cable is connected.

4.2 Measurement of the parameters of the RCD switch

The principal function of the RCD switch (**R**esidual **C**urrent **D**evice) is to provide additional protection against electric shock. The purpose the RCD switch is to disconnect the protected circuit in the case of an excessive leakage current in the circuit in question.

The measurement section of the RCD switch measures constantly the differential current I_{Δ} and causes disconnection of the protected circuit from the power supply source, if the differential current exceeds the characteristic value for the given switch. The value in question is the nominal differential current, which is indicated by the symbol $I_{\Delta n}$. The voltage on the housing of the protected device, in accordance with the Ohm's law, is:

$$U_B = I_{\Delta} \cdot R_E$$

here R_E is the resistance between the earth terminal of the protected device and the earth.

4.2.1 Realisation of measurements of the RCD switch parameters

In order to perform the measurement proceed as follows:

- connect the power supply network cable to the socket of the demonstration board,
- select the kind of network, **TT** or **TN**, using the jumper in the appropriate position (Figure 3),
- all the switches simulating irregularities must be in the „green“ position,
- turn the RCD switch on,
- connect the meter to the power network socket of the board using leads, in accordance with Figure 6,
- perform the measurement.

The demonstration board permits to simulate irregularities in an installation equipped with a RCD switch:

- The RCD switch-**T_A** in the in the „red“ position simulates an error consisting in shunting of the N PE lead with the RCD switch. During a measurement with this error, the RCD switch will not function, and the meter will display an adequate message, e.g. RCD.
- The RCD switch-**I_A** in the „red“ position causes an additional current leakage in the PE lead. During a measurement with this error the RCD switch will be activated at an incorrect moment (the T_A and I_{Δ} measurements will not be possible). The meter will display an adequate message, e.g. Err.
- Switch **U_B** in the „red“ position simulates a hazardous touch voltage during a measurement of the RCD parameters. Meter will display an adequate message, e.g. $U_B > 25$ V. If the meter is supposed to block the measurements and display this message, the acceptable touch voltage U_L set for the meter must not exceed 25 V. Should the acceptable touch voltage U_L during measurement be set at 50V, the meter will perform the measurements and display the results.

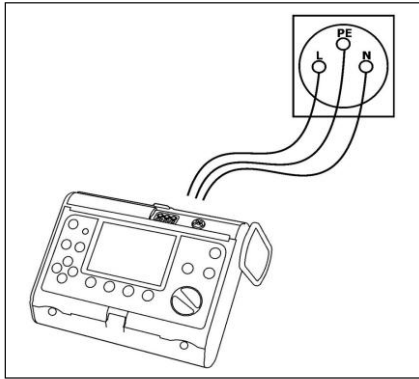

Fig. 6. Connection of the meter

Expected results

- Switches „green” RCD- T_A , RCD- I_A and U_B for the TN and TT network: $I_A = 15 \dots 30 \text{ mA}$, $T_A < 300 \text{ ms}$, $U_B \approx 0.2 \text{ V}$, $R_E \approx 0.00 \text{ k}\Omega$
- The RCD switch- T_A „red” for the TN and TT network: message „RCD”
- The RCD switch- I_A „red” for the TN and TT network: $I_A < 15 \text{ mA}$, or the message „Err”, „RCD activated during the measurement”
- Switch U_B „red” for the TN and TT network : $I_A = 15 \dots 30 \text{ mA}$, $T_A < 300 \text{ ms}$, $U_B \approx 31 \text{ V}$, $R_E \approx 1 \text{ k}\Omega$ or „excessive U_L voltage”

4.3 Measurements of the earth resistance

The quality of the earth systems significantly influence the safety of operation of electric installations and devices, and particularly the reliability of the protection from electric shock and lightning protection. Earth systems have also other functions related to safety, namely they are used to carry off electric charge where there is a risk of explosion (e.g. at petrol stations). In order to revise electric installations and fulfil the requirements related to the protection from electric shock, it is necessary to perform the measurements of earth resistance. The resistance in question permits to determine the value of touch voltage, which may be generated between different conductive elements of the protective lead.

In the case of measurements of a single earth system, the most common method is the 3-pole potential drop method. It consists in driving measurement electrodes into the ground near the earth system under test and forcing the passage of current in the following circuit: meter-the earth system in question-current electrode-meter.

Measurements of multiple earth systems may be performed using the aforementioned method, disconnecting subsequent earth electrodes during the measurement. Since it is an arduous task, the meters which are equipped with clamps may perform the measurement without the necessity to disconnect the measured earth system. In the case of this method the current and voltage electrodes are placed in a similar manner to the 3-pole method, but the current is measured with clamps which are fastened to the earth system under test. The meter calculates the resistance „knowing“ the current flowing through the tested earth electrode, and ignoring the current flowing through the adjacent earth electrodes. However the measurement method with clamps cannot be applied in those multiple systems in which individual earth electrodes are interconnected below the ground.

Measurements of multiple earth systems may be performed by means of the two-clamp method. This measurement is performed with two pairs of clamps – apart from the measurement clamps also transmission clamps must be used (whose internal structure is different). The transmission clamps induce current in the tested circuit. The value of the current is measured with measurement clamps. The result of the measurement is the resistance of the whole circuit through which the measurement current is flowing. Using this method, remember of the requirements: this function is excellent for the purpose of measurements of multiple earth systems of low and medium resistance values. In order to obtain a correct measurement the resistance of the earth electrode must be significantly higher than the resultant resistance value for the whole earth electrode system (the two-clamp measurement measures the sum of the resistance of the tested earthing resistance and the resultant value of the other earth resistances). The principal and considerable advantage of this measurement is the fact that there is no necessity to drive auxiliary electrodes into the ground.

There is also another method of an earth resistance measurements. This is the measurement of the surge earth resistance. The purpose of this measurement is to diagnose the dynamic parameters of lightning protection earth system. The surge measurement is performed at an excitation whose shape corresponds to a lightning pulse. The parameters of the pulse are defined by two values: the duration of the pulse leading edge t_1 and the duration of the semi-peak t_2 .

The DB-1 demonstration board permits to perform measurements of the earth resistance of three distinct earth electrodes, namely R_E , R_{E1} , R_{E2} . Earth resistance measurement R_{E2} is also possible using the clamp method. In order to perform such a measurement, instead of a jumper at the $E2$, it is necessary to use an **auxiliary lead**, which is included in the board delivery package and fasten the clamps on the lead. In order to perform the measurements it is also possible to use the meters of the MRU-10X and MRU-20X series. It is also allowed to use meters dedicated to measurements of the short circuit loop. However, using such a meter may activate the RCD switch.

4.3.1 Measurement of the earth electrode resistance using meters of the MRU series

a. Earth resistance measurement R_E

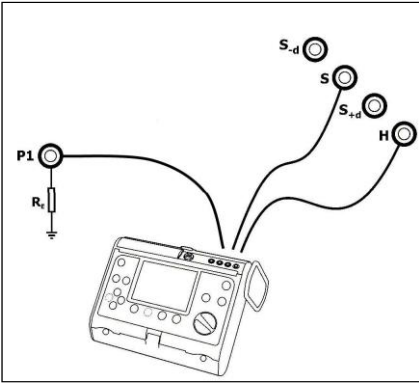

Fig. 7. Connection of the meter

In order to perform the R_E earth resistance measurement proceed as follows:

- disconnect the power supply network cable from the socket of the demonstration board,
- remove the **TN** or **TT** jumper, the **ZW H₂O** jumper, the earth electrode **R_{E1}**: **ZW R_{E1}** jumper
- a jumper may be fastened on the **R_{E2}** earth electrode,
- connect the earth resistance meter (MRU-XXX) to the sockets in accordance with Figure 7,
- perform the measurement.

Expected results

- $R_E = 100 \Omega$
- $R_H = 200 \Omega$
- $R_S = 200 \Omega$

b. Earth resistance measurement R_{E1}

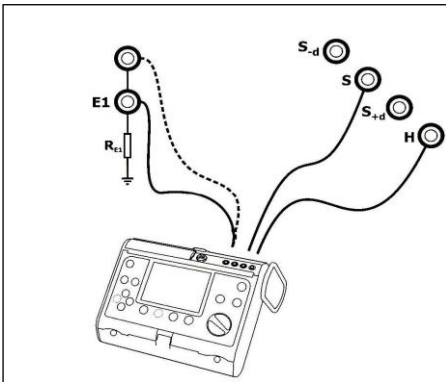

Fig. 8. Connection of the meter

In order to perform the R_{E1} earth resistance measurement proceed as follows:

- disconnect the power supply network cable from the socket of the demonstration board,
- remove the **TN** or **TT** jumper, the **ZW H₂O** jumper, the earth electrode **R_{E1}**: **ZW R_{E1}** jumper
- a jumper may be fastened on the **R_{E2}** earth electrode,
- connect the earth resistance meter (MRU-XXX) to the sockets in accordance with Figure 8,
- perform the measurement.

Expected results

- $R_{E1} = 4.7 \Omega$
- $R_H = 200 \Omega$
- $R_S = 200 \Omega$

c. **Earth resistance measurement R_{E2} by means of the technical method**

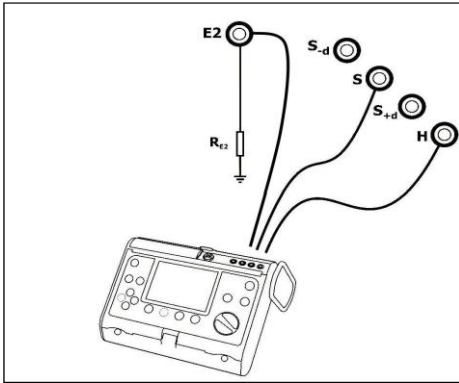

Fig. 9. Connection of the meter

In order to perform the R_{E2} earth resistance measurement proceed as follows:

- disconnect the power supply network cable from the socket of the demonstration board,
- remove the TN or TT jumper, the ZW H₂O jumper, the earth electrode R_{E1} : ZW R_{E1} jumper
- place a jumper on the R_{E2} ZW R_{E2} earth electrode,
- connect the earth resistance meter (MRU-XXX) to the sockets in accordance with Figure 9,
- perform the measurement.

Expected results

- $R_E = 6.8 \Omega$
- $R_H = 200 \Omega$
- $R_S = 200 \Omega$

d. **Earth resistance measurement R_{E2} by means of the technical method using current clamp**

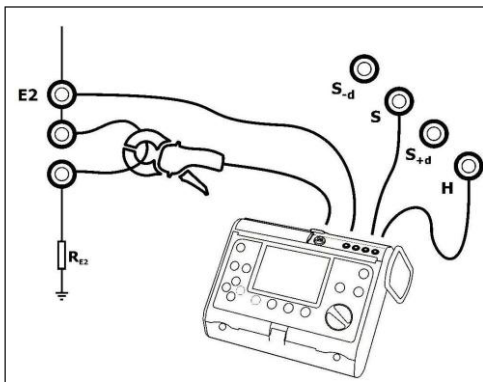

Fig. 10. Connection of the meter

In order to perform the R_{E2} earth resistance measurement using clamp proceed as follows:

- disconnect the power supply network cable from the socket of the demonstration board,
- since the measurement of the measurement current is performed with clamps, the user is free to place all the jumpers,
- use an **auxiliary lead**, instead of the jumper on the E2,
- connect the earth resistance meter (MRU-XXX) to the sockets in accordance with Figure 10,
- perform the measurement.

Expected results

- $R_E = 6.8 \Omega$
- $R_H = 200 \Omega$
- $R_S = 200 \Omega$

e. Earth resistance measurement R_{E2} by means of the two-clamp method

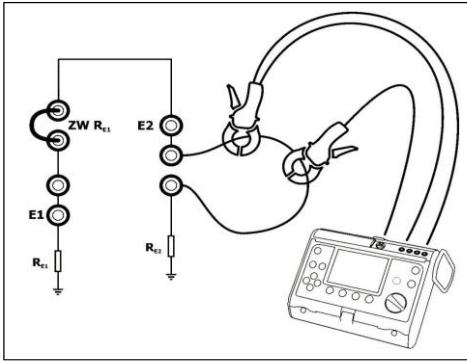

Fig. 11. Connection of the meter.

In order to perform the R_{E2} earth resistance measurement by means of the two-clamp method proceed as follows:

- disconnect the power supply network cable from the socket of the demonstration board,
- place a jumper on the $ZW R_{E1}$,
- remove the **TN** or **TT** jumper and the **ZW H₂O** jumper,
- use an **auxiliary lead**, instead of the jumper on the **E₂**,
- connect the earth resistance meter (MRU-XXX) to the sockets in accordance with Figure 11,
- perform the measurement.

Expected results

- $R_E = 11.5 \Omega$

4.3.2 Measurement of the earth resistance using loop impedance meters

Measurements of the earth resistance may also be performed with meters for measuring the short circuit loop impedance. In order to perform such measurements, the phase conductor of the power supply network is used as an auxiliary source of voltage which permits to generate the measurement current.

The result of the measurement is a sum of the impedance of the tested earth resistance, the working earth system, the source and the phase conductor, and thus it is burdened with a positive error. However if it does not exceed the acceptable value for the tested earth system, it may be assumed the earth system is properly constructed and there is no need to apply more precise measurement methods. Certain meters used for the purpose of measurements of the short circuit loop impedance may activate the differential RCD switch. This may influence the maximum measurement current and the time of generating such current by the meter. In order to avoid activation of the RCD switch, it is recommended to use the measurement of the short circuit loop impedance in the $Z_{L-PE[RCD]}$ function.

a. Earth resistance measurement R_E

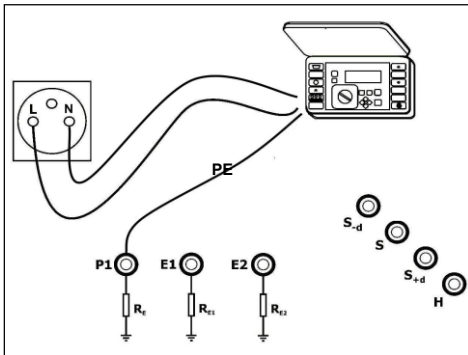

Fig. 12. Connection of the meter

In order to perform the R_E earth resistance measurement proceed as follows:

- connect the power supply network cable to the socket of the demonstration board,
- remove the **TN** or **TT** jumper, the **ZW H₂O** jumper, the earth electrode **RE₁**: **ZW RE₁** jumper,
- place a jumper on the **RE₂** earth electrode,
- turn the RCD switch on,
- connect meter of the short circuit loop impedance in accordance with Figure 12,
- perform the measurement,
- the measurement may provoke activation of the RCD switch (it is impossible to perform a measurement).

Expected results

- $R_E = 100 \Omega + Z_{L-N}$ of the network

b. Earth resistance measurement R_{E1}

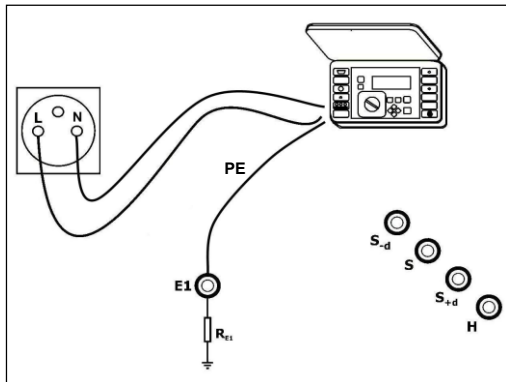

Fig. 13. Connection of the meter

In order to perform the R_{E1} earth resistance measurement proceed as follows:

- connect the power supply network cable to the socket of the demonstration board,
- remove the **TN** or **TT** jumper, the **ZW H₂O** jumper, the earth electrode R_{E1} : **ZW R_{E1}** jumper,
- turn the RCD switch on,
- connect meter of the short circuit loop impedance in accordance with Figure 13,
- perform the measurement,
- the measurement may provoke activation of the RCD switch (it is impossible to perform a measurement).

Expected results

- $R_E = 4.5 \Omega + Z_{L-N}$ of the network

c. Earth resistance measurement R_{E2}

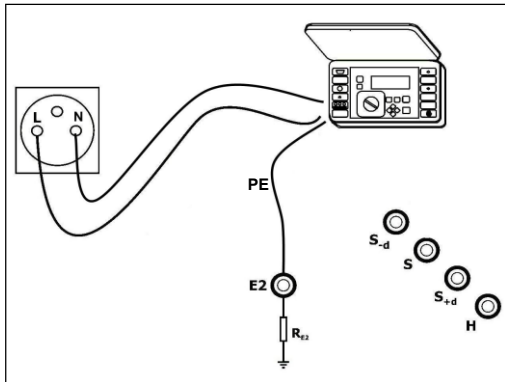

Fig. 14. Connection of the meter

In order to perform the R_{E2} earth resistance measurement proceed as follows:

- connect the power supply network cable to the socket of the demonstration board,
- remove the **TN** or **TT** jumper, the **ZW H₂O** jumper, the earth electrode R_{E1} : **ZW R_{E1}** jumper,
- place a jumper on the R_{E2} earth electrode,
- turn the RCD switch on,
- connect meter of the short circuit loop impedance in accordance with Figure 14,
- perform the measurement,
- the measurement may provoke activation of the RCD switch (it is impossible to perform a measurement).

Expected results

- $R_E = 6.8 \Omega + Z_{L-N}$ of the network

4.4 Earth resistivity measurements

Earth resistivity measurements are used to prepare designs of earth systems, in cathode protection or in geology.

Earth resistivity measurements are performed using four electrodes which are placed in line in equal distances (Wenner's method). In order to determine the ground resistivity value it is necessary to measure the resistance and perform calculations taking into account the distances between the electrodes. Modern meters permit to take into account the distances between the electrodes and all the calculations are performed automatically. The meter will display both the resistance value of the measurement probes (in Ω) and the ground resistivity value (in Ωm).

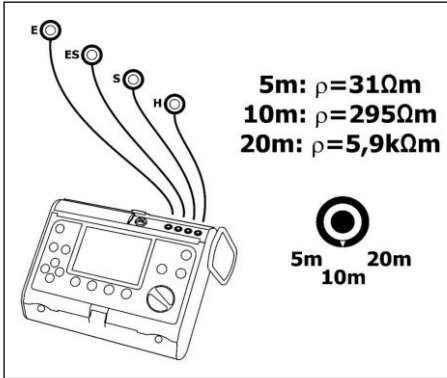

Fig. 15. Connection of the meter

In order to perform the measurement proceed as follows:

- disconnect the power supply network cable from the socket of the demonstration board,
- connect earth resistance and ground resistivity meter (MRU-XXX) to the sockets in accordance with Figure 5,
- place the „ground type selection” switch at the selected position,
- perform the measurement having previously entered to the meter the appropriate value of the distances between the measurement electrodes.

Expected results

- Switch in the position **5 m**: $\rho = 31 \Omega\text{m}$
- Switch in the position **10 m**: $\rho = 295 \Omega\text{m}$
- Switch in the position **20 m**: $\rho = 5.9 \text{ k}\Omega\text{m}$

4.5 Measurements of the continuity of equipotential bondings

Using the demonstration board it is possible to simulate a measurement of the resistance the equipotential bonding of an electric installation. The measurement may be performed between point **P1** of the equipotential bonding and point **P2** or **P3**. It is also possible to simulate irregularities related to the resistance of the equipotential bonding of point **P2** and point **P1**.

In order to activate this function the R_E switch simulating the irregularity must be placed in the „red” position.

4.5.1 Measurement of the resistance of the equipotential bonding between P1 and P2

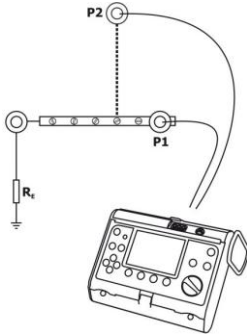

Fig. 16. Connection of the meter

In order to perform a measurement of the resistance of equipotential bonding between **P1** and **P2** proceed as follows:

- disconnect the power supply network cable from the socket of the demonstration board,
- place all the switches simulating irregularities in the „green” position,
- turn the RCD switch off,
- connect the meter with cables to the network socket of the board in accordance with Figure 16,
- perform the measurement,
- change the position of the irregularities switch R_E to the „red” position,
- perform the measurement.

Expected results

- Switch R_E in the „green” position: $R_{cont}(P1-P2) = 0.4 \Omega$
- Switch R_E in the „red” position: $R_{cont}(P1-P2) = 1 \text{ k}\Omega$

4.5.2 Measurement of the resistance of equipotential bonding between P1 and P3

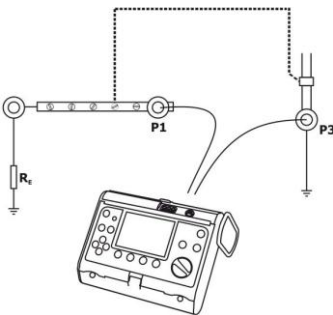

Fig. 17. Connection of the meter

In order to perform a measurement of the resistance of equipotential bonding between **P1** and **P3** proceed as follows:

- disconnect the power supply network cable from the socket of the demonstration board,
- place all the switches simulating irregularities in the „green” position,
- turn the RCD switch off,
- insert the **ZW H₂O** jumper,
- connect the meter with cables to the network socket of the board in accordance with Figure 17,
- perform the measurement.

Expected results

- $R_{cont}(P1-P3) = 0.4 \Omega$

4.6 Insulation resistance measurement

The purpose of the insulation resistance measurements is to determine the conditions of the installation insulation and electric power loads. The conditions of the insulation is a decisive factor in the context of safety of operation and correct functioning of electrical devices. Good insulation is, apart from other means of protection, also a guarantee of protection from direct touch.

Before the measurements are performed, make sure the measured object is disconnected from the power supply network. This is why the meters manufactured by SONEL S.A. are equipped with a voltmeter.

The demonstration board permits a simulation of an insulation resistance measurement. The measurement may be performed in the **L-N** and **L-PE** circuits.



NOTE!

The test voltage must not exceed 1 kV.

4.6.1 Insulation resistance measurements in the L-N circuit

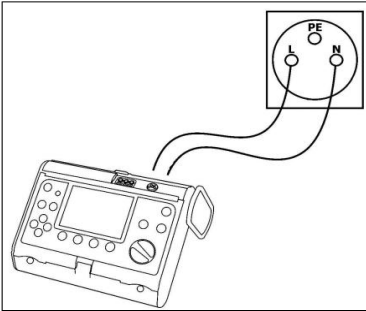

Fig. 18. Connection of the meter

In order to perform the measurement of the insulation resistance in the **L-N** circuit proceed as follows:

- disconnect the power supply network cable from the socket of the demonstration board,
- place all the switches simulating irregularities in the „green” position,
- turn the RCD switch off,
- connect the meter with cables to the network socket in the board in accordance with Figure 18,
- perform the measurement,
- change the position switch of the irregularities of the resistance of insulation $R_{ISO(L-N)}$ to the „red” position,
- perform the measurement.

Expected results

- Switch $R_{ISO(L-N)}$ „green” position: $R_{ISO(L-N)} = 100 \text{ M}\Omega$
- Switch $R_{ISO(L-N)}$ „red” position: $R_{ISO(L-N)} = 100 \text{ k}\Omega$

4.6.2 Insulation resistance measurements in the L-PE circuits

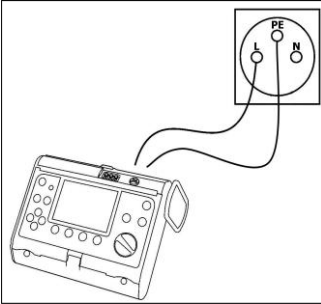

Fig. 19. Connection of the meter

In order to perform the measurement of the insulation resistance in the L-PE circuit proceed as follows:

- disconnect the power supply network cable from the socket of the demonstration board,
- place all the switches simulating irregularities in the „green” position,
- turn the RCD switch off,
- connect the meter with cables to the network socket in the board in accordance with Figure 19,
- perform the measurement,
- change the position switch of the irregularities of the resistance of insulation $R_{ISO(L-PE)}$ to the „red” position,
- perform the measurement.

Expected results

- Switch $R_{ISO(L-PE)}$ „green” position: $R_{ISO(L-PE)} \geq 3 \text{ G}\Omega$
- Switch $R_{ISO(L-PE)}$ „red” position: $R_{ISO(L-PE)} = 200 \text{ k}\Omega$

5 Replacement of fuses

In the case a defect of the device has been detected, when the signalling diode „POWER” is off in spite of a correct connection of the device to the power supply network, it is recommended to check the condition of the fuse elements. The fuse elements are in the mains socket from which the device is powered.

In order to do so, disconnect the power supply cord from the device and raise the fuse compartment using flat screwdriver. The compartment contains two fuses.

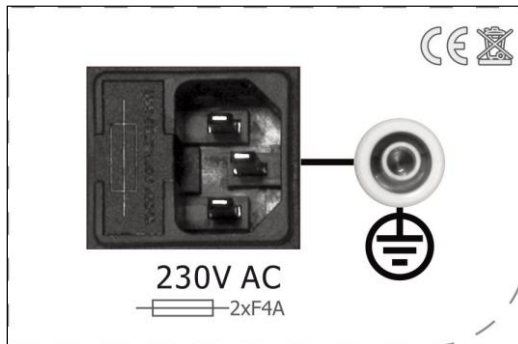

Fig. 20. Position of the fuses



NOTE!

Solely the following fuse elements are approved for the demonstration board: F4A 250 V or T3,15 250 V. In the case fuse elements which are not specified in the present manual are used, there is a risk of damage to the device and a serious danger for the user.

6 Cleaning and maintenance



NOTE!

Use only the maintenance methods specified in this manual.

The casing of the device may be cleaned with a soft, damp cloth using all-purpose detergents. Do not use any solvents or cleaning agents which might scratch the casing (powders, pastes, etc.). The electronic system does not require maintenance.

7 Dismantling and disposal

Worn-out electric and electronic equipment should be gathered selectively, i.e. it must not be placed with waste of another kind.

Worn-out electronic equipment should be sent to a collection point in accordance with the law of waste electrical and electronic equipment.

Before the equipment is sent to a collection point, do not dismantle any elements.

Observe local regulations concerning disposal of packages, waste batteries and accumulators.

8 Technical specifications

- a) measurement category acc. to EN 61010-1 CAT II 300 V
- b) type of insulation acc. to EN 61010-1 single
- c) ingress protection acc. to EN 60529..... IP40
- d) power supply..... 220...240 V, 50/60 Hz network
- e) max. power consumption ca. 15 mW
- f) RCD type30 mA type AC
- g) dimensions..... 405 x 300 x 140 mm
- h) weight ca. 3.6 kg
- i) operating temperature..... +10... +40°C
- j) storage temperature..... -20... +60°C
- k) quality standard design, construction and manufacturing are ISO 9001 compliant
- l) the product meets EMC requirements acc. to..... EN 61000-1 3-2, 3-3

9 Manufacturer

The manufacturer and provider of warranty and post-warranty service:

SONEL S.A.

Wokulskiego 11
58-100 Świdnica
Poland

tel. +48 74 884 10 53 (Customer Service)

e-mail: customerservice@sonel.com

web page: www.sonel.com



NOTE!

Service repairs must be performed only by the manufacturer.

NOTES

NOTES



SONEL S.A.

Wokulskiego 11
58-100 Świdnica
Poland

Customer Service

tel. +48 74 884 10 53
e-mail: customerservice@sonel.com

www.sonel.com