

USER MANUAL

GPS-1 MODULE



USER MANUAL

GPS-1 MODULE



**SONEL S.A.
Wokulskiego 11
58-100 Świdnica
Poland**

Version 1.01 07.01.2026



- Due to continuous product development, the manufacturer reserves the right to make changes to functionality, features and technical parameters of the analyzers. The manufacturer provides long-term support for the product, adding new functionalities and fixing noticed errors.
- This manual describes the firmware version 1.00.



CONTENTS

1	General information	4
1.1	Safety symbols	4
1.2	Safety	4
1.3	General characteristics	4
1.4	Module assembly	6
1.5	Screw terminal connections	6
2	Module operation	7
3	Firmware update	7
4	IRIG-B generator	8
4.1	IRIG-B format	9
4.2	IRIG-B frame structure	10
5	Technical data	13
5.1	Time synchronization	13
5.2	IRIG-B port	13
5.3	Environmental conditions and other technical data	13
5.4	Standards	14
6	Cleaning and maintenance	15
7	Storage	15
8	Dismantling and utilization	15
9	Manufacturer	15

1 General information

1.1 Safety symbols

The following international symbols are used on the module and in this manual:

	Do not dispose of with other household waste		Declaration of Conformity with EU directives (<i>Conformité Européenne</i>)		Conforms to relevant Australian standards
--	--	---	---	---	---

1.2 Safety

To avoid electric shock or fire, you must observe the following guidelines:

- Before you proceed to operate the module, acquaint yourself thoroughly with the present manual and observe the safety regulations and specifications provided by the manufacturer.
- Any application that differs from those specified in the present manual may result in damage to the device and constitute a source of danger for the user.
- Before starting the work, check the module, wires, and other accessories for any sign of mechanical damage.
- It is unacceptable to operate the device when:
 - ⇒ it is damaged and completely or partially out of order,
 - ⇒ its cords and cables have damaged insulation,
 - ⇒ any of the accessories is mechanically damaged.
- Repairs may be performed only by an authorized service point.

1.3 General characteristics

The GPS-1 module is an accessory dedicated to the PQM-750 power quality analyzer. It is a GPS receiver with an SMA-type connector to which an external GPS antenna is connected. The GPS receiver synchronizes the analyzer's time with the Coordinated Universal Time (UTC) and ensures microsecond-level measurement time-stamping accuracy.

Three GPS antenna variants are available for use with the GPS-1 module:

- with a 10-meter cable,
- with a 20-meter cable,
- with a 30-meter cable.

The module can also function as a time synchronization signal server using the IRIG-B standard. The IRIG-B signal generator allows for synchronization with other PQM-750 analyzers or other devices supporting the IRIG-B standard. The physical interface used is RS-485, enabling long-distance signal transmission with a bus architecture.

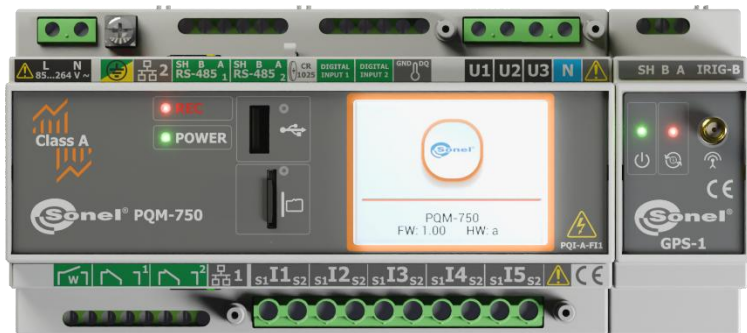

Fig. 1. View of the PQM-750 analyzer with the GPS-1 module connected.

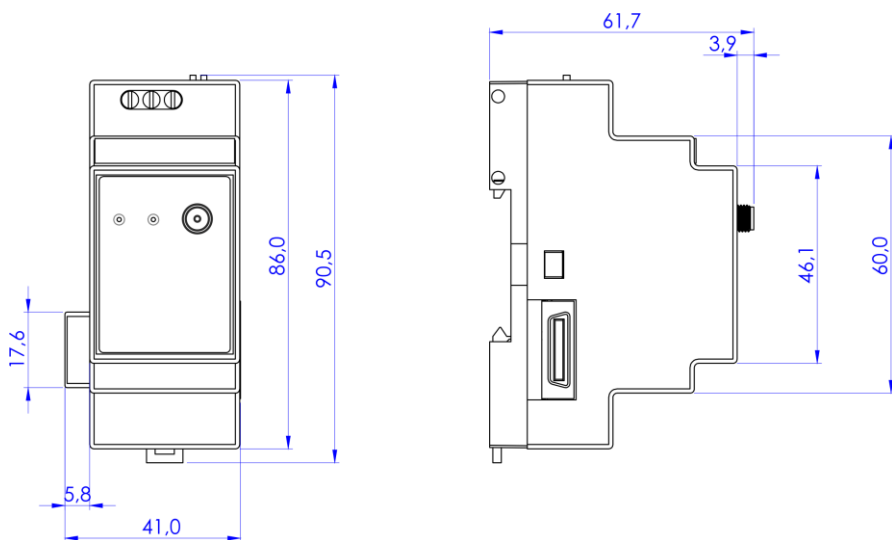

Fig. 2. External dimensions of the module (in millimeters).

1.4 Module assembly

The module is designed to work with the PQM-750 analyzer and is also powered by it. To connect the module, follow the procedure below:

- Disconnect the PQM-750 analyzer from the power supply and then turn it off according to user manual.
- Place the GPS-1 module on a 35 mm DIN rail (if used) and slide it to the right side of the PQM-750 analyzer so that the side connector of the GPS-1 module fully engages the analyzer's expansion connector.
- Secure the GPS-1 module on the right side with a mechanical lock to prevent accidental disconnection from the analyzer.
- Connect the GPS antenna to the GPS-1 module and (optionally) connect the cables to the IRIG-B server output.
- Connect the PQM-750 analyzer to the power supply. The analyzer will turn on automatically.

To remove the GPS-1 module:

- Disconnect the PQM-750 analyzer from the power supply and then turn it off following the user manual.
- Disconnect the GPS antenna and IRIG-B output cables from the module (if used).
- Remove any mechanical locking devices on the modules.
- Disconnect the GPS-1 from the analyzer by sliding the module to the right.
- If the module is mounted on a 35 mm DIN rail, use a tool to pull down the lower tab on the module and then tilt the bottom of the module toward you.
- Connect the PQM-750 analyzer to the power supply. The analyzer will turn on automatically.



CAUTION!

Additional modules should only be connected to the PQM-750 meter after the power is turned off and the main module is powered off. Failure to follow this recommendation may result in damage to the meter and/or the connected module.

1.5 Screw terminal connections

Table 1 lists all the screw terminals of the GPS-1 module.

Tab. 1. GPS-1 module screw terminals.

Terminal name	Terminal number	Designation	Wire cross-section in mm ²	Strip length in mm
IRIG-B (RS-485)	1	A/+	0.5...3.3	6
	2	B/-		
	3	shielding		

2 Module operation

The GPS-1 module begins operation immediately after the master PQM-750 analyzer is powered on. Two LEDs are used to monitor the module's operation.

- **Green** (power supply):
 - Continuous light – correct operation.
 - Flashing at a frequency of 1 Hz – module initialization error.
- **Red** (synchronization status):
 - Continuous light – a state of correct time synchronization, high time accuracy (better than 100 μ s), and IRIG-B generator active.
 - A repeating sequence of 2.5 seconds of continuous light followed by 0.5 seconds off – indicates a state where the time accuracy is better than ± 1 ms but worse than 100 μ s. Such a situation can occur when the GPS antenna is disconnected, but the analyzer's time accuracy is still sufficient to mark measurement data as required by standards. The IRIG-B signal is generated.
 - Flashing at a frequency of 1 Hz – no time synchronization with the GPS clock, or the time accuracy is worse than 1 ms. IRIG-B generation depends on whether synchronization has previously been achieved. If this state has been achieved, the IRIG-B signal is continuously generated. If the synchronization state has not been obtained at any time since the module was powered on, IRIG-B signal generation is disabled.

The time required to obtain GPS synchronization depends on weather conditions (clouds, precipitation) and on location of receiving antenna. The antenna should be provided with high "visibility" of the sky in order to obtain the best results. To read the time with the required accuracy, the GPS receiver must first determine its own current geographical location (it must "see" at least 4 satellites - position and altitude).

After determining the position and synchronizing its internal clock with UTC time, the receiver enters the tracking mode. To ensure time synchronization in this mode, the visibility of only one GPS satellite is required. However, to determine the analyzer position (when it is moved), additional satellites must be visible (four for position and altitude or three if GPS does not update altitude data).

An additional important reason for extending the synchronization time with UTC is the need to read information about leap seconds. A packet with this information is broadcast by GPS satellites every 12.5 minutes, which can be a decisive factor in increasing the time required to achieve synchronization.

3 Firmware update

When new module firmware is released, it is included in the PQM-750 analyzer update package. The module update file is saved to the analyzer's internal memory card during the update. If the analyzer detects a GPS-1 module with an older firmware version during startup, it will automatically update it.

4 IRIG-B generator

The GPS-1 module has a built-in output that generates an unmodulated IRIG-B time synchronization signal in the RS-485 electrical standard. This output can be used to synchronize the time of other PQM-750 analyzers using their IRIG-B inputs or other devices with a compatible input.

The GPS-1 module ensures very low error in the generated IRIG-B signal relative to the GPS receiver. Advanced IRIG-B generator control uses a hardware solution that relates the generated 1PPS signal edge from the GPS receiver to the edge of the generated IRIG-B signal at the change of second.

The IRIG-B generator transmits time information encoded in 100 bits, with each bit lasting 10 ms. The full current time is transmitted every second.

The IRIG-B signal is activated after the first time synchronization is achieved (the red LED is lit continuously) and remains active until the module is powered off. It's important to remember that the IRIG-B signal is also generated when the time accuracy drops below 1 ms (e.g., when there's no signal from the GPS antenna for an extended period). The signal recipient can decide how to use the signal in such a situation – the encoded bit stream broadcast by the server includes information about the time accuracy (see the detailed description of the IRIG-B frame – [sec. 4.2](#)).

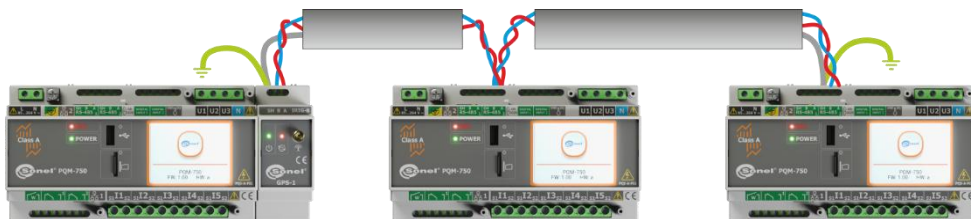

Fig. 3. Example of an IRIG-B synchronization network

Fig. 3 shows an example in which one PQM-750 analyzer synchronizes two other analyzers with a GPS-1 module. Twisted-pair cables are recommended for connections. Unshielded cables can be used for short connections, but shielded cables will increase the network's immunity to electromagnetic interference, especially in wide-area networks. Because the output on the GPS-1 module and the IRIG-B inputs on the PQM-750 analyzers are galvanically isolated, the "SH" shield terminals are also isolated. Therefore, they must be independently grounded, as shown in Fig. 3, to ensure that the cable shields are grounded on at least one side. Grounding on both sides is also acceptable.

For a wide-area network, e.g., exceeding several dozen meters, it is advisable to include terminating resistors at the ends of the bus (switches are located next to the terminals). This will prevent signal reflections and possible disruptions to the integrity of IRIG-B frames.

4.1 IRIG-B format

IRIG-B (*Inter Range Instrumentation Group Time Code Format B*) is the most common type of information encoding within the IRIG family of formats. It originates from a U.S. Army standard published in 1960. The latest version is Standard 200-04 "IRIG Serial Time Code Formats" from 2004.

In IRIG-B encoding, time is transmitted once per second, in binary-coded decimal (BCD) format, and optionally includes a binary seconds-of-day counter. The standard allows for a number of configurations, designated *IRIG-Bxyz*, where:

- *B* – denotes a transmission rate of 100 bits per second and a frame duration of 1 second,
- *x* – denotes the modulation technique,
- *y* – denotes the carrier frequency/resolution,
- *z* – denotes the frame content.

The format used in the GPS-1 module is **IRIG-B004**.

Tab. 2. IRIG format types. The format used in GPS-1 is marked with a background color and bold text.

Character/Number	Description	
Letter (Format)	Transmission rate	Frame duration
A	1000 pps	100 ms
B	100 pps	1 s
D	1 ppm	1 h
E	10 pps	10 s
G	10000 pps	10 ms
H	1 pps	60 s
1 digit	Modulation type	
0	Pulse width code	
1	Amplitude modulation, sine wave	
2	Manchester modulated	
2 digit	Carrier frequency / Resolution	
0	None / none	
1	100 Hz / 10 ms	
2	1 kHz / 1 ms	
3	10 kHz / 100 ms	
4	100 kHz / 10 ms	
5	1 MHz / 1 ms	
3 digit	Coded information	
0	BCD _{TOY} , CF, SBS	
1	BCD _{TOY} , CF	
2	BCD _{TOY}	
3	BCD _{TOY} , SBS	
4	BCD_{TOY}, BCD_{YEAR}, CF, SBS	
5	BCD _{TOY} , BCD _{YEAR} , CF	
6	BCD _{TOY} , BCD _{YEAR}	
7	BCD _{TOY} , BCD _{YEAR} , SBS	

Symbols used in Table 2:

- pps (*pulse per second*)
- ppm (*pulse per minute*)
- BCD (*Binary Coded Decimal*)
- CF (*Control Functions*)
- SBS (*Straight Binary Seconds*)
- TOY (*Time of Year*)
- YEAR

4.2 IRIG-B frame structure

A single IRIG-B frame is transmitted once per second and contains 100 bits, each lasting 10 milliseconds. The following bit encodings are used (Fig. 4):

- Bit "0" – high state 2 ms, low state 8 ms,
- Bit "1" – high state 5 ms, low state 5 ms,
- Bit "Px" – high state 8 ms, low state 2 ms.

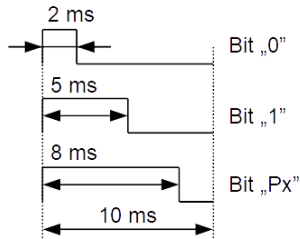

Fig. 4. The method of encoding bits in an IRIG-B frame.

Table 3 shows the frame structure in the IRIG-B004 coding standard as implemented in the GPS-1 module. Bits marked: Pref, P0...P9, have the form of the "Px" bit.

Tab. 3. IRIG-B004 frame construction.

Time [ms]	Meaning	Description
0	Pref	Reference bit. The rising edge of this bit indicates the start of a new second.
10	1	Bits of the units digit of the seconds (BCD encoding)
20	2	
30	4	
40	8	
50	0	Unused bit
60	10	Bits of the tens digit of the seconds (BCD encoding)
70	20	
80	40	
90	P1	
100	1	Bits of the units digit of the minutes (BCD encoding)
110	2	
120	4	
130	8	
140	0	Unused bit
150	10	Bits of the tens digit of the minutes (BCD encoding)
160	20	
170	40	
180	0	
190	P2	Position index
200	1	Bits of the units digit of the hours (BCD encoding)

Time [ms]	Meaning	Description
210	2	
220	4	
230	8	
240	0	Unused bit
250	10	
260	20	Bits of the tens digit of the hours (BCD encoding)
270	0	Unused bit
280	0	Unused bit
290	P3	Position index
300	1	
310	2	
320	4	
330	8	
340	0	Unused bit
350	10	
360	20	
370	40	
380	80	
390	P4	Position index
400	100	
410	200	Bits of the digits of the hundreds of days (BCD encoding)
420	0	Unused bit
430	0	Unused bit
440	0	Unused bit
450	0	Unused bit
460	0	Unused bit
470	0	Unused bit
480	0	Unused bit
490	P5	Position index
500	1	
510	2	
520	4	
530	8	
540	0	Unused bit
550	10	
560	20	
570	40	
580	80	
590	P6	Position index
600	CF1 (LSP)	Leap second waiting (LSP). This field displays 1 in 59 seconds BEFORE the leap second event until the LS event.
610	CF2 (LS)	Leap second (LS). This bit is only filled if the CF1 (LSP) bit is 1. Otherwise, it is 0. 0 = add a second 1 = subtract a second
620	CF3	Unused bit (=0)
630	CF4	Unused bit (=0)
640	CF5	Unused bit (=0)
650	CF6	Unused bit (=0)
660	CF7	Unused bit (=0)
670	CF8	Unused bit (=0)
680	CF9	Unused bit (=0)
690	P7	Position index
700	CF10	Unused bit (=0)
710	CF11 (TQ 2 ⁰)	
720	CF12 (TQ 2 ¹)	
730	CF13 (TQ 2 ²)	
740	CF14 (TQ 2 ³)	
		Time quality A 4-bit number (0...15) representing the approximate clock time error. See Table 4.

Time [ms]	Meaning	Description
750	CF15	Parity bit. The parity of all preceding data bits.
760	CF16 (CTQ 2 ⁰)	Continuous Time Quality A 3-bit number (0...7) representing the estimated maximum timing error in the transmitted frame. CTQ indicates the error at any time. See Table 5.
770	CF17 (CTQ 2 ¹)	
780	CF18 (CTQ 2 ²)	
790	P8	
800	2 ⁰	Binary seconds of the day counter (lower 9 bits)
810	2 ¹	
820	2 ²	
830	2 ³	
840	2 ⁴	
850	2 ⁵	
860	2 ⁶	
870	2 ⁷	
880	2 ⁸	
890	P9	Position index
900	2 ⁹	Binary seconds of the day counter (higher 8 bits)
910	2 ¹⁰	
920	2 ¹¹	
930	2 ¹²	
940	2 ¹³	
950	2 ¹⁴	
960	2 ¹⁵	
970	2 ¹⁶	
980	0	
990	P0	Position index

Tab. 4. Time Quality field

Binary (2 ³ ...2 ⁰)	Decimal	Description – Worst-case accuracy
1111	15	Error – clock failure, time uncertain
1011	11	Time accuracy <10 s relative to UTC
1010	10	Time accuracy <1 s relative to UTC
1001	9	Time accuracy <100 ms relative to UTC
1000	8	Time accuracy <10 ms relative to UTC
0111	7	Time accuracy <1 ms relative to UTC
0110	6	Time accuracy <100 µs relative to UTC
0101	5	Time accuracy <10 µs relative to UTC
0100	4	Time accuracy <1 µs relative to UTC
0011	3	Time accuracy <100 ns relative to UTC
0010	2	Time accuracy <10 ns relative to UTC
0001	1	Time accuracy <1 ns relative to UTC
0000	0	Clock tracks UTC time source (unused value)

Tab. 5. Continuous Time Quality field

Binary (2 ² ...2 ⁰)	Decimal	Description – Worst-case accuracy
111	7	Estimated maximum time error >10 ms or time error unknown
110	6	Estimated maximum time error <10 ms
101	5	Estimated maximum time error <1 ms
100	4	Estimated maximum time error <100 µs
011	3	Estimated maximum time error <10 µs
010	2	Estimated maximum time error <1 µs
001	1	Estimated maximum time error <100 ns
000	0	Unused value

5 Technical data

- Specifications are subject to change without prior notice. Recent revisions of technical documentation are available at the manufacturer's website.

5.1 Time synchronization

Time synchronization	
Supported GNSS Systems	GPS, BeiDou, GLONASS, Galileo
1PPS output accuracy (Internal)	<20 ns (clear sky) <500 ns (indoors)
Antenna	External active (10 m / 20 m / 30 m), magnetic mount, SMA connector.
Time from power on to synchronization (clear sky)	From 1 to 12.5 minutes (the maximum time is due to the interval between the GPS system's leap-second announcements)

5.2 IRIG-B port

IRIG-B port	
IRIG-B format	IRIG-B004
Isolation type	Digital isolator
Physical standard	RS-485
Isolation voltage	1000 Vrms
Max. number of receivers	100
Max. bus length	1000 m
Terminating resistors	Enabled – "ON" (top) indicates a resistor connected (120 Ω between A and B)
Time generation accuracy	±10 ns relative to the 1PPS signal from the GPS receiver (measured at the IRIG-B port terminals). A delay of approximately 5 ns should be added for each meter of twisted-pair cable used between the GPS-1 module and the receiver when the measurement is performed from the receiver side.

5.3 Environmental conditions and other technical data

Environmental conditions and other technical data	
Operating temperature range:	-20°C...+55°C
Storage temperature range	-30°C...+60°C
Humidity	10...90%
Ingress protection (according to IEC 60529)	IP30, indoor use only
Power consumption	< 1 W
Dimensions	41 x 87 x 62 mm
Weight	65 g

5.4 Standards



Conformity Note

SONEL S.A. hereby declares that the device type GPS-1 complies with Directives 2014/35/UE and 2014/30/UE. The full text of the EU Declaration of Conformity is available at the following website address: <https://sonel.pl/en/download/declaration-of-conformity/>

Standards	
Safety	IEC 61010-1:2010/AMD1:2016 (Ed. 3.0) Insulation (PQM-750 + GPS-1 set): single + protective grounding terminal (Protection Class I)
EMC	EN 55032 (CISPR 32):2015 IEC 61000-6-5:2015
Quality standard	Design, construction and manufacturing are ISO 9001 compliant

6 Cleaning and maintenance



NOTE!

Use only the maintenance methods specified by the manufacturer in this manual.

The casing of the module may be cleaned with a soft, damp cloth using all-purpose detergents. Do not use any solvents or cleaning agents which might scratch the casing (powders, pastes, etc.). The module electronic system does not require maintenance.

7 Storage

In the case of storage of the module, the following recommendations must be observed:

- Disconnect all the test leads and antenna from the module.
- Clean the module and all its accessories thoroughly.

8 Dismantling and utilization

Worn-out electric and electronic equipment should be gathered selectively, i.e. it must not be placed with waste of another kind.

Worn-out electronic equipment should be sent to a collection point in accordance with the electrical and electronic equipment waste law.

Before the equipment is sent to a collection point, do not dismantle any elements.

Observe local regulations concerning disposal of packages, waste batteries and accumulators.

9 Manufacturer

The manufacturer of the device and the provider of guarantee and post-guarantee services is:

SONEL S.A.

Wokulskiego 11

58-100 Świdnica

Poland

tel. +48 74 884 10 53 (Customer Service)

e-mail: customerservice@sonel.com

web page: www.sonel.com



NOTE!

Service repairs must be performed only by the manufacturer.

NOTES



SONEL S.A.

Wokulskiego 11
58-100 Świdnica
Poland

Customer Service

tel. +48 74 884 10 53
e-mail: customerservice@sonel.com

www.sonel.com