

USER MANUAL

POWER QUALITY ANALYZER

PQM-700



USER MANUAL

POWER QUALITY ANALYZER PQM-700



**SONEL S.A.
Wokulskiego 11
58-100 Świdnica
Poland**

Version 1.21.2 24.02.2026



Due to continuous product development, the manufacturer reserves the right to make changes to functionality, features and technical parameters of the analyzers. This manual describes the firmware version 1.21 and the SoneI Analysis v4.7.1 software.











CONTENTS

1	General information	5
1.1	Safety.....	5
1.2	General characteristics	6
1.3	Power supply of the analyzer	8
1.4	Tightness and outdoor operation.....	9
1.5	Mounting on DIN rail	10
1.6	Measured parameters.....	11
1.7	Compliance with standards	13
2	Operation of the analyzer	14
2.1	Buttons.....	14
2.2	Signalling LEDs.....	14
2.3	Switching the analyzer ON/OFF.....	15
2.4	Auto-off.....	15
2.5	PC connection and data transmission.....	15
2.6	Indication of connection error.....	16
2.7	Warning about too high voltage or current	17
2.8	Taking measurements.....	17
2.8.1	Start / stop of recording.....	17
2.8.2	Approximate recording times	17
2.9	Measuring arrangements	18
2.10	Inrush current.....	23
2.11	Key Lock	23
2.12	Sleep mode	23
2.13	Firmware update	24
2.13.1	Automatic update.....	24
2.13.2	Manual update.....	24
3	"Sonel Analysis" software	25
4	Design and measurement methods	26
4.1	Voltage inputs	26
4.2	Current inputs.....	26
4.2.1	Digital integrator.....	26
4.3	Signal sampling.....	27
4.4	PLL synchronization.....	27
4.5	Frequency measurement	27
4.6	Event detection	28
5	Calculation formulas.....	30
5.1	One-phase network.....	30
5.2	Split-phase network.....	34
5.3	3-phase wye network with N conductor.....	36
5.4	3-phase wye and delta network without neutral conductor.....	38
5.5	Methods of parameter's averaging.....	40

6	Technical specifications	41
6.1	Inputs	41
6.2	Sampling and RTC.....	42
6.3	Measured parameters - accuracy, resolution and ranges	42
6.3.1	Reference conditions	42
6.3.2	Voltage	42
6.3.3	Current	43
6.3.4	Frequency	44
6.3.5	Harmonics	44
6.3.6	Power and energy.....	44
6.3.7	Estimating the uncertainty of power and energy measurements.....	45
6.3.8	Flicker.....	46
6.3.9	Unbalance	47
6.4	Event detection - voltage and current RMS.....	47
6.5	Event detection - other parameters	47
6.5.1	Event detection hysteresis	48
6.6	Inrush current measurement	48
6.7	Recording.....	48
6.8	Power supply, battery and heater.....	49
6.9	Supported networks	50
6.10	Supported current probes	50
6.11	Communication	50
6.12	Environmental conditions and other technical data	51
6.13	Safety and electromagnetic compatibility	51
6.14	Standards.....	51
7	Cleaning and maintenance	52
8	Storage.....	52
9	Dismantling and disposal	52
10	Optional accessories	53
11	Manufacturer	54

1 General information

The following international symbols are used on the analyzer and in this manual:

	Warning; See explanation in manual		Functional earth terminal		Alternating voltage/ current
	Direct voltage/ current		Double Insulation (Protection Class)		Conforms to relevant European Union direc- tives (Conformité Européenne)
	Do not dispose of this product as un- sorted municipal waste		Recycling information		Conforms to relevant Australian standards
	<p>UL/cUL Safety Certification Mark</p> <p>The PQM-700 (US model) analyzer has been investigated and certified by Underwriters Laboratories (UL) in accordance with the following Standards: UL 61010-1, 3rd Edition, May 11, 2012, Revised July 15 2015, IEC 61010-2-030: 2010 (First Edition), UL 61010-2-030: 2012 (First Edition), CAN/CSA-C22.2 No. 61010-1-12, 3rd Edition, Revision dated July 2015, CAN/CSA-C22.2 No. 61010-2-030-12 (First Edition).</p> <p>It is UL/cUL listed under the UL File: E490376.</p>				

1.1 Safety



Warning

To avoid electric shock or fire, you must observe the following guidelines:

- Before you proceed to operate the analyzer, acquaint yourself thoroughly with the present manual and observe the safety regulations and specifications provided by the producer.
- Any application that differs from those specified in the present manual may result in damage to the device and constitute a source of danger for the user.
- Analyzers must be operated only by appropriately qualified personnel with relevant certificates authorizing the personnel to perform works on electric systems. Operating the analyzer by unauthorized personnel may result in damage to the device and constitute a source of danger for the user.
- The device must not be used for networks and devices in areas with special conditions, e.g. fire-risk and explosive-risk areas.
- Before starting the work, check the analyzer, wires, current probes and other accessories for any sign of mechanical damage. Pay special attention to the connectors.
- It is unacceptable to operate the device when:
 - ⇒ it is damaged and completely or partially out of order,
 - ⇒ its cords and cables have damaged insulation,
 - ⇒ of the device and accessories mechanically damaged.
- Do not power the analyzer from sources other than those listed in this manual.
- Do not connect inputs of the analyzer to voltages higher than the rated values.

- **Use accessories and probes with a suitable rating and measuring category for the tested circuit.**
- **Do not exceed the rated parameters of the lowest measurement category (CAT) of the used measurement set consisting of the analyzer, probes and accessories. The measurement category of the entire set is the same as of the component with the lowest measurement category.**
- **If possible, connect the analyzer to the de-energized circuits.**
- **Opening the device socket plugs results in the loss of its tightness, leading to a possible damage in adverse weather conditions. It may also expose the user to the risk of electric shock.**
- **Do not handle or move the device while holding it only by its cables.**
- **Do not unscrew the nuts from the cable glands, as they are permanently fixed. Unscrewing the nuts will void the guarantee.**
- **Repairs may be performed only by an authorized service point.**

The analyzer is equipped with an internal Li-Ion battery, which has been tested by an independent laboratory and is quality-certified for compliance with the standard *UN Manual of Tests and Criteria Part III Subsection 38.3 (ST/SG/AC.10/11/Rev.5)*. Therefore, the analyzer is approved for air, maritime and road transport.

1.2 General characteristics

Power Quality Analyzer PQM-700 (Fig. 1) is a high-tech device providing its users with a comprehensive features for measuring, analysing and recording parameters of 50/60 Hz power networks and power quality in accordance with the European Standard EN 50160. The analyzer is fully compliant with the requirements of IEC 61000-4-30, Class S.

The device is equipped with four cables terminated with banana plugs, marked as L1, L2, L3, N. The range of voltages measured by the four measurement channels is max. ± 1150 V. This range may be extended by using external voltage transducers.

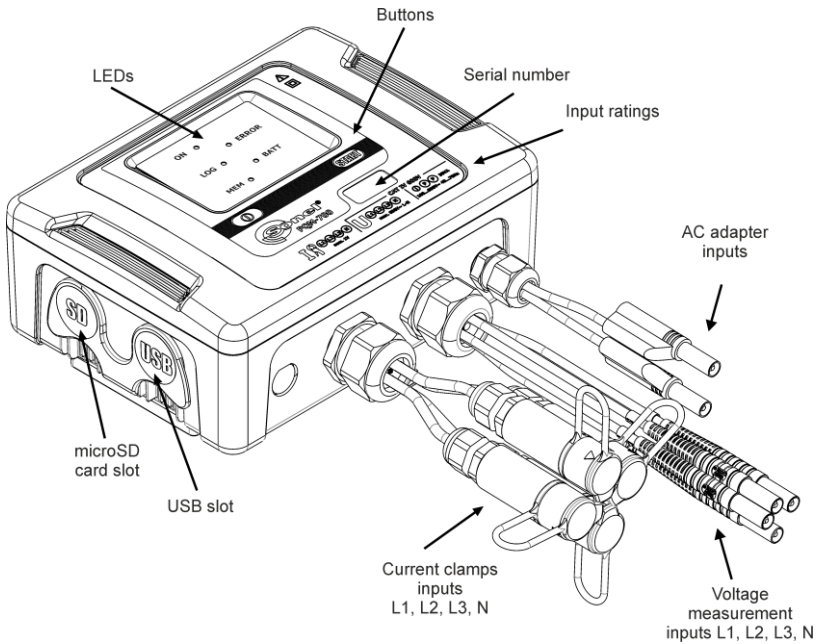

Fig. 1. Power Quality Analyser PQM-700. General view.

Current measurements are carried out using four current inputs installed on short cables terminated with clamp terminals. The terminals may be connected to the following probe types: flexible probes with nominal rating up to 6000 A and hard clamps. Also in case of current, the nominal range may be changed by using additional transformers.

The device has a built-in 2 GB microSD memory card. Data from the memory card may be read via USB slot or by an external reader.

Note

microSD card may be removed only when the analyser is turned off. Removing the card during the operation of the analyser may result in the loss of important data.

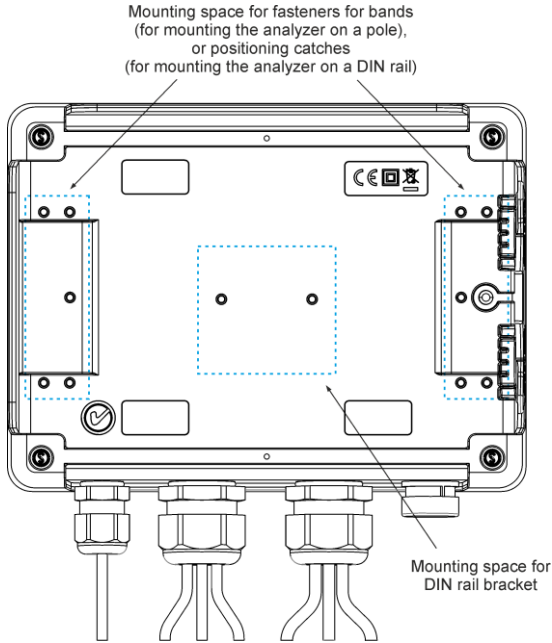

Fig. 2. The rear wall of PQM-700 analyzer.

Recorded parameters are divided into groups that may be independently turned on/off for recording purposes and this solution facilitates the rational management of the space on the memory card. Parameters that are not recorded, leave more memory space for further measurements.

PQM-700 has an internal power supply adapter operating in a wide input voltage range (100...415 V AC / 140...415 V DC), which is provided with independent cables terminated with banana plugs.

An important feature of the device is its ability to operate in harsh weather conditions – the analyzer may be installed directly on electric poles. The ingress protection class of the analyzer is IP65, and operating temperature ranges from -20°C to +55°C.

Uninterrupted operation of the device (in case of power failure) is ensured by an internal rechargeable lithium-ion battery.

The user interface consists of five LEDs and 2 buttons.

The full potential of the device may be released by using dedicated PC software *Sonel Analysis*.

Communication with a PC is possible via USB connection, which provides the transmission speed up to 921.6 kbit/s

1.3 Power supply of the analyzer

The analyzer has a built-in power adapter with nominal voltage range of 100...415 V AC / 140...415 V DC (90...460 V AC / 127...460 V DC including fluctuations). The power adapter has independent terminals (red cables) marked with letter P (*power*) To prevent the power adapter from being damaged by undervoltage, it automatically switches off when powered with input voltages below approx. 80 V AC (110 V DC).

To maintain power supply to the device during power outages, the internal rechargeable battery is used. It is charged when the voltage is present at terminals of the AC adapter. The battery is able to maintain power supply up to 6 hours at temperatures of -20 °C...+55 °C. After the bat-



tery is discharged the meter stops its current operations (e.g. recording) and switches off in the emergency mode. When the power supply from mains returns, the analyzer resumes interrupted recording.

Note

The battery may be replaced only by the manufacturer's service department.

1.4 Tightness and outdoor operation

PQM-700 analyzer is designed to work in difficult weather conditions – it can be installed directly on electric poles. Two bands with buckles and two plastic fasteners are used for mounting the analyzer. The fasteners are screwed to the back wall of the housing, and bands should be passed through the resulting gaps.

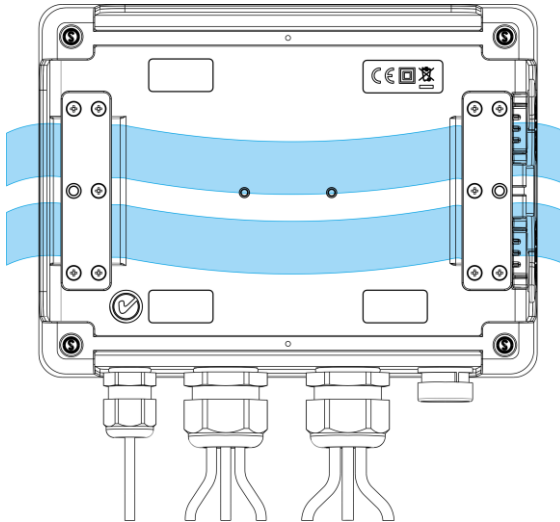

Fig. 3. Fasteners for bands (for mounting the analyzer on a pole)

The ingress protection class of the analyzer is IP65, and operating temperature ranges from -20°C to $+55^{\circ}\text{C}$.

Note

In order to ensure the declared ingress protection class IP65, the following rules must be observed:

- *Tightly insert the stoppers in the slots of USB and microSD card,*
- *Unused clamp terminals must be sealed with silicone stoppers.*

At ambient temperatures below 0°C or when the internal temperature drops below this point, the internal heater of the device is switched on – its task is to keep the internal temperature above zero, when ambient temperatures range from -20°C to 0°C .

The heater is powered from AC/DC adapter, and its power is limited to approx. 5 W.

1 General information

Due to the characteristics of the built-in lithium-ion rechargeable battery, the process of charging is blocked when the battery temperature is outside the range of 0°C...60°C (in such case, *SoneI Analysis* software indicates charging status as "charging suspended").

1.5 Mounting on DIN rail

The device is supplied with a bracket for mounting the analyzer on a standard DIN rail. The bracket must be fixed to the back of the analyzer with the provided screws. The set includes also positioning catches (in addition to fasteners for mounting the analyzer on a pole), which should be installed to increase the stability of the mounting assembly. These catches have special hooks that are supported on the DIN rail.

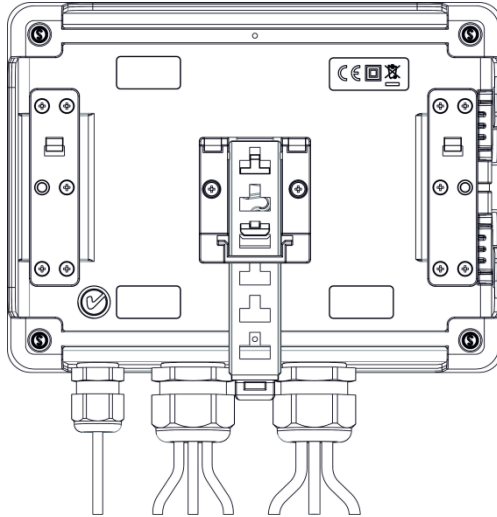

Fig. 4. The rear wall of the analyzer with fixtures for mounting on DIN rail.

1.6 Measured parameters

PQM-700 analyzer is designed to measure and record the following parameters:

- RMS phase and phase-to-phase voltages – up to 760 V (peak voltages ± 1150 V),
- RMS currents:
 - up to 6000 A (peak currents up to ± 20 kA) using flexible probes,
 - up to 1400 A using hard clamps,
- crest factors for current and voltage,
- mains frequency within the range of 40...70 Hz,
- active, reactive and apparent power and energy, distortion power,
- harmonics of voltages and currents (up to 50th),
- Total Harmonic Distortion THD_F and THD_R for current and voltage,
- power factor, $\cos\phi$, 4-quadrant $\tan\phi$,
- unbalance factors for three-phase mains and symmetrical components,
- flicker P_{ST} and P_{LT} ,
- inrush current for up to 60 s.

Some of the parameters are aggregated (averaged) according to the time selected by the user and may be stored on a memory card. In addition to average value, it is also possible to record minimum and maximum values during the averaging period, and to record the current value occurring in the time of measurement.

The module for event detection is also expanded. According to EN 50160, typical events include voltage dip (reduction of RMS voltage to less than 90% of nominal voltage), swell (exceeding 110% of the nominal value) and interruption (reduction of the supplied voltage below 5% of the nominal voltage) The user does not have to enter the settings defined in EN 50160, as the software provides an automatic configuration of the device to obtain energy measurement mode compliant with EN 50160 The user may also perform manual configuration – the software is fully flexible in this area. Voltage is only one of many parameters for which the limits of event detection may be defined. For example, the analyzer may be configured to detect power factor drop below a defined value, THD exceeding another threshold, and the 9th voltage harmonic exceeding a user-defined percentage value. Each event is recorded along with the time of occurrence. For events that relate to exceeding the pre-defined limits for voltage dip, swell, interruption, and exceeding minimum and maximum current values, the recorded information may also include a waveform for voltage and current. It is possible to save two periods before the event, and four after the event.

A very wide range of configurations, including a multitude of measured parameters make PQM-700 analyzer an extremely useful and powerful tool for measuring and analysing all kinds of power supply systems and interferences occurring in them. Some of the unique features of this device make it distinguishable from other similar analyzers available in the market.

Tab. 1 presents a summary of parameters measured by PQM-700, depending on the mains type.

Tab. 1. Measured parameters for different network configurations.

Network type, channel Parameter		1-phase		2-phase			3-phase wye with N,					3-phase triangle 3-phase wye without N,				
		L1/A	N	L1/A	L2/B	N	Σ	L1/A	L2/B	L3/C	N	Σ	L12/AB	L23/BC	L31/CA	Σ
U	RMS voltage	•		•	•			•	•	•			•	•	•	
U _{DC}	Voltage DC component	•		•	•			•	•	•			•	•	•	
I	RMS current	•	•	•	•	•		•	•	•	•		•	•	•	
I _{DC}	Current DC component	•	•	•	•	•		•	•	•	•		•	•	•	
F	Frequency	•		•				•					•			
CF U	Voltage crest factor	•		•	•			•	•	•			•	•	•	
CF I	Current crest factor	•	•	•	•	•		•	•	•	•		•	•	•	
P	Active power	•		•	•		•	•	•	•	•					•
Q ₁ , Q _B	Reactive power	•		•	•		•	•	•	•	•					• ⁽¹⁾
D, S _N	Distortion power	•		•	•		•	•	•	•	•					
S	Apparent power	•		•	•		•	•	•	•	•					•
PF	Power Factor	•		•	•		•	•	•	•	•					•
cosφ	Displacement power factor	•		•	•		•	•	•	•	•					
tanφ _{C-} , tanφ _{L-} , tanφ _{L+} , tanφ _{C+}	Tangent φ factor (4-quadrant)	•		•	•		•	•	•	•	•					• ⁽¹⁾
THD U	Voltage Total harmonic distortion	•		•	•			•	•	•			•	•	•	
THD I	Current Total harmonic distortion	•	•	•	•	•		•	•	•	•		•	•	•	
E _{P+} , E _{P-}	Active energy (consumed and supplied)	•		•	•		•	•	•	•	•					•
E _{QC-} , E _{OL+} , E _{QL-} , E _{QC+}	Reactive energy (4-quadrant)	•		•	•		•	•	•	•	•					• ⁽¹⁾
E _S	Apparent energy	•		•	•		•	•	•	•	•					•
U _{h1..U_{h50}}	Voltage harmonic amplitudes	•		•	•			•	•	•			•	•	•	
I _{h1..I_{h50}}	Current harmonic amplitudes	•	•	•	•	•		•	•	•	•		•	•	•	
Unbalance U, I	Symmetrical components and unbalance factors															•
P _{st} , P _{It}	Flicker factors	•		•	•			•	•	•			•	•	•	

Explanations: L1/A, L2/B, L3/C (L12/AB, L23/BC, L31/CA) indicate subsequent phases

N is a measurement for current channel I_N ,

Σ is the total value for the system.

- (1) In 3-wire networks, the total reactive power is calculated as inactive power $N = \sqrt{S_g^2 - P^2}$ (see discussion on reactive power in Power Quality Guide document)

1.7 Compliance with standards

PQM-700 is designed to meet the requirements of the following standards.

Standards valid for measuring network parameters:

- IEC 61000-4-30:2009 – Electromagnetic compatibility (EMC) - Testing and measurement techniques - Power quality measurement methods,
- IEC 61000-4-7:2002 – Electromagnetic compatibility (EMC) – Testing and Measurement Techniques - General Guide on Harmonics and Interharmonics Measurements and Instrumentation for Power Supply Systems and Equipment Connected to them,
- IEC 61000-4-15:2011 – Electromagnetic compatibility (EMC) – Testing and Measurement Techniques - Flickermeter – Functional and Design Specifications,
- EN 50160:2010 – Voltage characteristics of electricity supplied by public distribution networks.

Safety standards:

- IEC 61010-1 – Safety requirements for electrical equipment for measurement control and laboratory use. Part 1: General requirements

Standards for electromagnetic compatibility:

- IEC 61326 – Electrical equipment for measurement, control and laboratory use. Requirements for electromagnetic compatibility (EMC).



The device meets all the requirements of Class S as defined in IEC 61000-4-30. The summary of the requirements is presented in the table below.

Tab. 2. Summary of selected parameters in terms of their compliance with the standards

Aggregation of measurements at different intervals	IEC 61000-4-30 Class S: <ul style="list-style-type: none"> • Basic measurement time for parameters (voltage, current, harmonics, unbalance) is a 10-period interval for 50 Hz power supply system and 12-period interval for 60 Hz system, • Interval of 3 s (150 periods for the nominal frequency of 50 Hz and 180 periods for 60 Hz), • Interval of 10 minutes.
Real-time clock (RTC) uncertainty	IEC 61000-4-30 Class S: <ul style="list-style-type: none"> • Built-in real-time clock, set via <i>Sone!</i> Analysis software, no GPS/radio synchronization. • Clock accuracy better than ± 0.3 seconds/day
Frequency	Compliant with IEC 61000-4-30 Class S of the measurement method and uncertainty
Power supply voltage	Compliant with IEC 61000-4-30 Class S of the measurement method and uncertainty
Voltage fluctuations (flicker)	The measurement method and uncertainty meets the requirements of IEC 61000-4-15 standard.
Dips, interruptions and swells of supply voltage	Compliant with IEC 61000-4-30 Class S of the measurement method and uncertainty
Supply voltage unbalance	Compliant with IEC 61000-4-30 Class S of the measurement method and uncertainty
Voltage and current harmonics	Measurement method and uncertainty is in accordance with IEC 61000-4-7 Class I

2 Operation of the analyzer

2.1 Buttons





The keyboard of the analyzer consists of two buttons: ON/OFF  and START/STOP . To switch-on the analyzer, press ON/OFF button. START/STOP button is used to start and stop recording.

2.2 Signalling LEDs



The analyzer is equipped with five LEDs that indicate different operating states:

- **ON** (green) – the LED is on when the analyzer is turned on. During recording with activated sleep mode, the LED is off.
- **LOG** (yellow) – indicates recording in process. In standby mode the LED is lit continuously. During recording it flashes. During recording with activated sleep mode – it is off and then switched on in 10-sec. intervals.
- **ERROR** (red) – blinking of this LED indicates a potential problem with connecting to the tested network or the incompatibility of the active configuration with network parameters. Control criteria are defined in section 2.6. Continuous light indicates one of the possible internal errors of the analyzer (see also the description of additional statuses presented below).
- **MEM** (red) – when this LED is on, it indicates that the data cannot be recorded on the memory card. **MEM** LED is continuously lit when the entire space on the memory card is filled. See also the description of additional statuses presented below.
- **BATT** (red) - battery status. Blinking indicates that the battery is low (charged in 20% or less). When the battery is completely discharged, LED lights up for 5 seconds (with beep) and then the analyzer is switched off in emergency mode.

Additional statuses indicated by LEDs:

- Continuous light of **MEM** and **ERROR** LEDs – no memory card, card damaged or card error. When these LEDs are on after inserting a memory card, it may indicate that the card is incompatible with the analyzer. In this case there is no possibility of further work with the analyzer. START  button is inactive.
- Continuous light of **ERROR** LED and blinking **MEM** LED – card is not formatted (missing files required by the analyzer or files damaged) – in this case you can press the START  button (it is active), which will format the card (NOTE: all data on the card will be deleted). If the process is successful, **MEM** and **ERROR** LEDs will go off and the analyzer will be ready for further work.
- Blinking **ON** LED – FIRMWARE.PQF file detected on the card, containing the correct firmware update file. You may press the START button  to begin the update process. During the update process **ON** and **MEM** LEDs blink simultaneously. After this process is completed, the meter will restart. You may skip the firmware update by pressing the ON/OFF button  or by waiting 10 seconds.

2.3 Switching the analyzer ON/OFF

- The analyzer may be switched-on by pressing button . Green **ON** LED indicates that analyzer is switched on. Then, the analyzer performs a self-test and when an internal fault is detected, **ERROR** LED is lit and a long beep (3 seconds) is emitted – measurements are blocked. After the self-test, the meter begins to test if the connected mains configuration is the same as the configuration in analyzer's memory, and when an error is detected **ERROR** LED flashes every 0.5 seconds. When **ERROR** LED flashes the analyzer still operates as normal and measurements are possible.
- When the meter is switched on and detects full memory, **MEM** LED is lit – measurements are blocked, only read-out mode for current data remains active.
- When the meter is switched on and fails to detect the micro-SD card or detects its damage, **ERROR** and **MEM** LEDs are lit and measurements are blocked.
- If the connection test was successful, after pressing  the meter enters the recording mode, as programmed in the PC.
- To switch the analyzer OFF, keep button  pressed for 2 seconds, when no button or recording lock are active.



2.4 Auto-off

When the analyzer operates for at least 30 minutes powered by the battery (no power supply from mains) and it is not in the recording mode and PC connection is inactive, the device automatically turns-off to prevent discharging the battery.

The analyzer turns off automatically also when the battery is fully discharged. Such an emergency stop is preceded by activating BATT LED for 5 s and it is performed regardless of the current mode of the analyzer. In case of active recording, it will be interrupted. When the power supply returns, the recording process is resumed.

2.5 PC connection and data transmission

When the meter is switched-on, its USB port remains active.

- In the read-out mode for current data, PC software refreshes data with a frequency higher than once every 1 second.
- During the recording process, the meter may transmit data already saved in memory. Data may be read until the data transmission starts.
- During the recording process the user may view mains parameters in PC:
 - instantaneous values of current, voltage, all power values, total values for three phases,
 - harmonics and THD,
 - unbalance,
 - phasor diagrams for voltages and currents,
 - current and voltage waveforms drawn in real-time.
- When connected to a PC, button  is locked, but when the analyzer operates with key lock mode (e.g. during recording),  button is also locked.
- To connect to the analyzer, enter its PIN code. The default code is 000 (three zeros). The PIN code may be changed using *Sonel Analysis* software.
- When wrong PIN is entered three times in a row, data transmission is blocked for 10 minutes. Only after this time, it will be possible to re-entry PIN.
- When within 30 sec of connecting a PC to the device no data exchange occurs between the analyzer and the computer, the analyzer exits data exchange mode and terminates the connection.

Notes

- Holding down buttons **START** and **ⓘ** for 5 seconds results in an emergency setting of PIN code (000).
- If you the keys are locked during the recording process, this lock has a higher priority (first the user would have to unlock buttons to reset the emergency PIN). This is described in section 2.11.

USB is an interface that is continuously active and there is no way to disable it. To connect the analyzer, connect USB cable to your PC (USB slot in the device is located on the left side and is secured with a sealing cap). Before connecting the device, install *SoneI Analysis* software with the drivers on the computer. Transmission speed is 921.6 kbit/s.

2.6 Indication of connection error

During operation, the analyzer continuously monitors the measured parameters for compliance with the current configuration. Basing on several criteria listed below, the analyzer controls the lighting of **ERROR** LED. If the analyzer does not detect any inconsistency, this LED remains off. When at least one of the criteria indicates a potential problem, **ERROR** LED starts to blink.

The criteria used by the analyzer for detecting a connection error are as follows:

- deviation of RMS voltage exceeding $\pm 15\%$ of nominal value,
- deviation of the phase angle of the voltage fundamental component exceeding $\pm 30^\circ$ of the theoretical value with resistive load and symmetrical mains (see note below)
- deviation of the phase angle of the current fundamental component exceeding $\pm 55^\circ$ of the theoretical value with resistive load and symmetrical mains (see note below)
- network frequency deviation exceeding $\pm 10\%$ of the nominal frequency,
- in 3-phase 3- and 4-wire systems the analyzer also calculates the sum of all the currents (instantaneous values) and checks if it totals to zero. This helps in determining if all current probes are connected correctly (i.e. arrows on current probes facing to the load). If the calculated current sum RMS value is higher then 0.3% of I_{nom} it is treated as an error and blinking **ERROR** LED.

Note

To detect a phase error, the fundamental component of the measured sequence must be at least equal to 5% of the nominal voltage, or 1% of the nominal current. If this condition is not fulfilled, the correctness of angles is not verified.





2.7 Warning about too high voltage or current

During its operation, the analyzer monitors continuously the value of voltages and currents connected to the measuring inputs. If the voltage of any active phase exceeds approx. 20% of the nominal voltage ($>120\% U_{NOM}$) set in the measurement configuration, a two-tone continuous beep is activated. The same applies for currents – an alarm signal is activated if the measured current in any of the active channels exceeds 20% of nominal current (range of clamps; $>120\% I_{NOM}$). In such a situation, check whether the voltage and current in the measured network is within voltage and current limits allowable for the analyzer or check if the analyzer configuration is correct and change it, if necessary.



2.8 Taking measurements

2.8.1 Start / stop of recording

Recording may be triggered in three ways:

- immediate triggering - manually by pressing  button after configuring the meter from a PC – **LOG** LED flashes,
- scheduled triggering - according to time set in the PC. The user must first press  button to enter recording stand-by mode; in this case pressing  button does not trigger the recording process immediately (the meter waits for the first pre-set time and starts automatically). In standby mode **LOG** LED is lit continuously, after triggering it flashes,
- threshold triggering. The user must first press  button to enter recording stand-by mode; in this case pressing  button does not trigger the recording process immediately – the normal recording starts automatically after exceeding any threshold set in the settings. In standby mode **LOG** LED is lit continuously, after triggering it flashes.

Stopping the recording process:

- Recording may be manually stopped by holding for one second button  or from the PC application.
- Recording ends automatically as scheduled (if the end time is set), in other cases the user stops the recording (using button  or the software).
- Recording ends automatically when the memory card is full.
- After finishing the recording, when the meter is not in the sleep mode, **LOG** LED turns off and the meter waits for next operator commands.
- If the meter had LEDs turned-off during the recording process, then after finishing the recording no LED is lit; pressing any button activates **ON** LED.

2.8.2 Approximate recording times

The maximum recording time depends on many factors such as the size of the memory card, averaging time, the type of system, number of recorded parameters, waveforms recording, event detection, and event thresholds. A few selected configurations are given in Tab. 3. The last column presents approximate recording times for 2 GB memory card. The typical configurations shown in Tab. 3 assumes that I_N current measurement is enabled.

Tab. 3. Approximate recording times for a few typical configurations.

Configuration mode/profile	Averaging time	System type (current measurement on)	Events	Event waveforms	Waveforms after averaging period	Approximate recording time with 2GB allocated space
according to EN 50160	10 min	3-phase wye	• (1000 events)	• (1000 events)		60 years
according to the "Voltages and currents" profile	1 s	3-phase wye				270 days
according to the "Power and harmonics" profile	1 s	3-phase wye				23 days
according to the "Power and harmonics" profile	1 s	3-phase wye	• (1000 events)	• (1000 events)		22.5 day
all possible parameters	10 min	3-phase wye				4 years
all possible parameters	10 s	3-phase wye				25 days
all possible parameters	10 s	1-phase				64 days
all possible parameters	10 s	1-phase	• (1000 events / day)	• (1000 events / day)		22 days

2.9 Measuring arrangements

The analyzer may be connected directly and indirectly to the following types of networks:

- 1-phase (Fig. 5),
- 2-phase (split-phase) with split-winding of the transformer (Fig. 6),
- 3-phase wye with a neutral conductor (Fig. 7),
- 3-phase wye without neutral conductor (Fig. 8),
- 3-phase delta (Fig. 9).

In three-wire systems, current may be measured by the Aron method, which uses only two clamps that measure linear currents I_{L1} and I_{L3} . I_{L2} jest current is then calculated using the following formula:

$$I_{L2} = -I_{L1} - I_{L3}$$

This method can be used in delta systems (Fig. 10) and wye systems without a neutral conductor (Fig. 11).

Note

As the voltage measuring channels in the analyzer are referenced to N input, then in systems where the neutral is not present, it is necessary to connect N input to L3 network terminal. In such systems, it is not required to connect L3 input of the analyzer to the tested network. It is shown in Fig. 8, Fig. 9, Fig. 10 and Fig. 11 (three-wire systems of wye and delta type).

In systems with neutral conductor, the user may additionally activate current measurement in this conductor, after installing additional clamps in I_N channel. This measurement is performed after activating in settings the option of **Current in N conductor**.

Note

*In order to correctly calculate total apparent power S_e and total Power Factor (PF) in a 4-wire 3-phase system, it is necessary to measure the current in the neutral conductor. Then it is necessary to activate option **Current in N conductor** and to install 4 clamps as shown in Fig. 7. More information may be found in Power Quality Guide document.*

Pay attention to the direction of current clamps (flexible and CT). The clamps should be installed with the arrow indicating the load direction. It may be verified by checking an active power measurement - in most types of passive receivers active power is positive. When clamps are incorrectly connected, it is possible to change their polarity using *Sonel Analysis* software.

The following figures show schematically how to connect the analyzer to the tested network depending on its type.

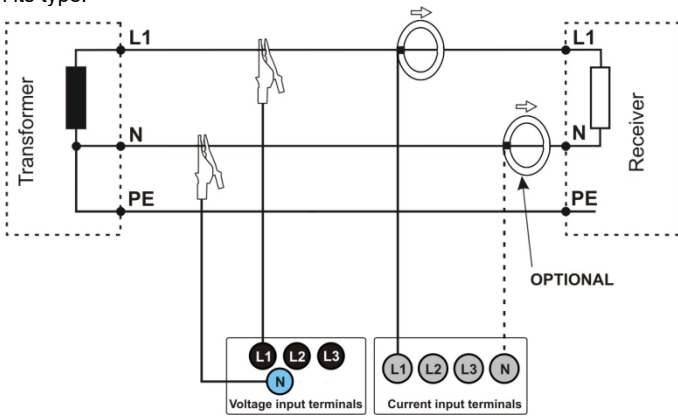

Fig. 5. Wiring diagram – single phase.

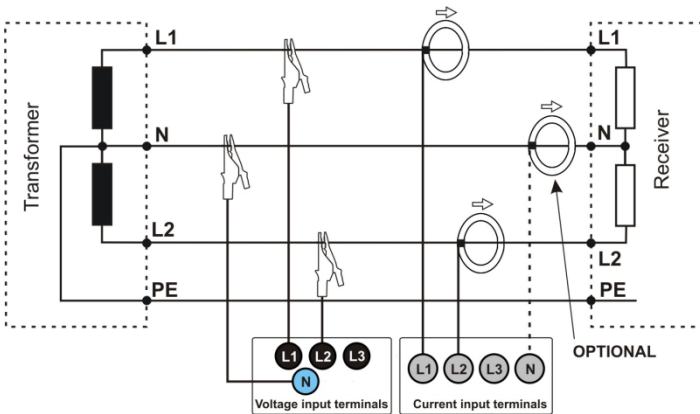

Fig. 6. Wiring diagram – 2-phase.

2 Operation of the analyzer

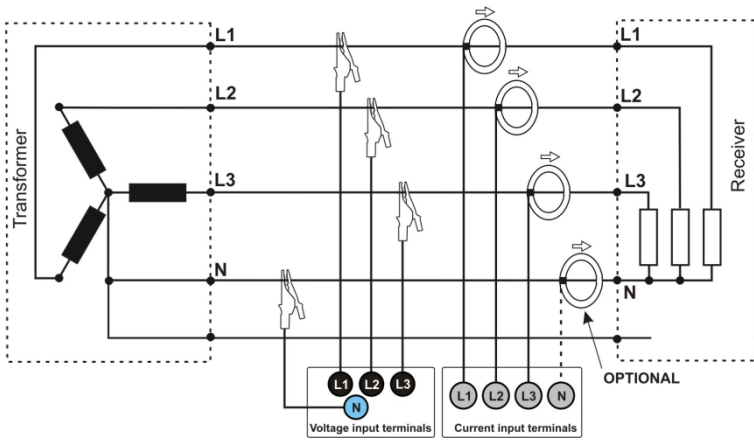

Fig. 7. Wiring diagram – 3-phase wye with a neutral conductor.

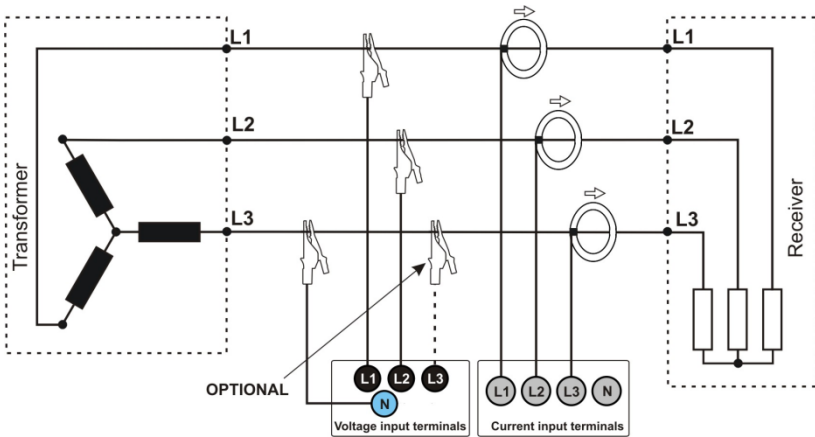

Fig. 8. Wiring diagram – 3-phase wye without neutral conductor.

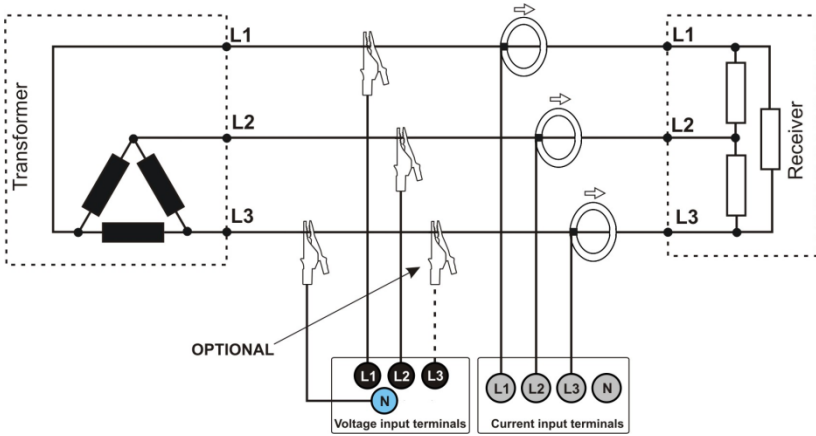

Fig. 9. Wiring diagram – 3-phase delta.

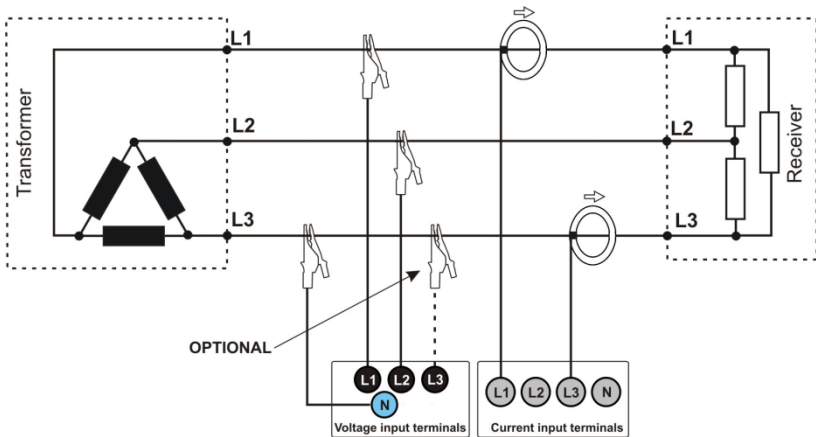

Fig. 10. Wiring diagram – 3-phase delta (current measurement using Aron method).

2 Operation of the analyzer

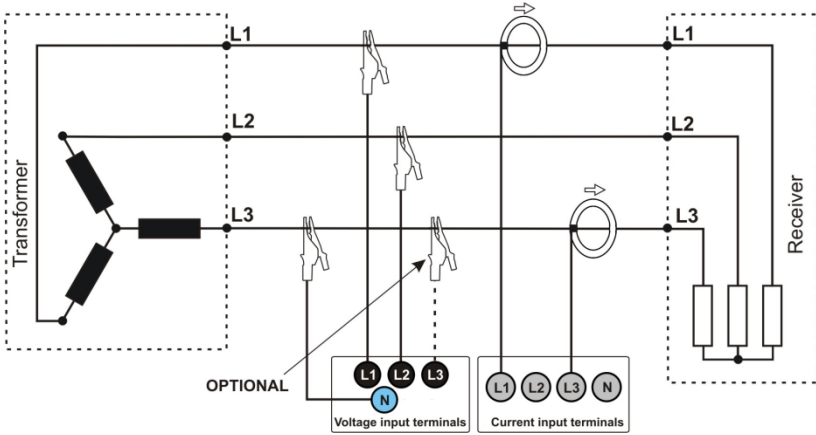

Fig. 11. Wiring diagram – 3-phase wye without neutral conductor (current measurement using Aron method).

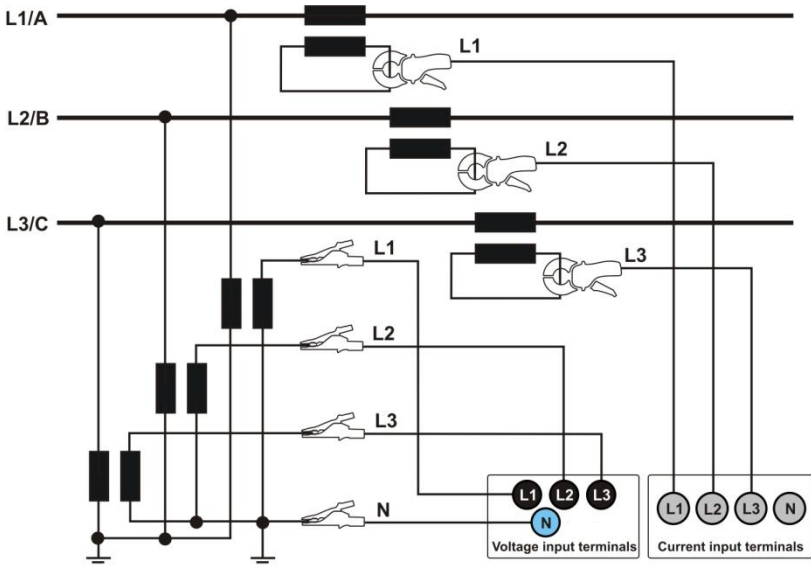

Fig. 12. Wiring diagram – indirect system with transducers – wye configuration.

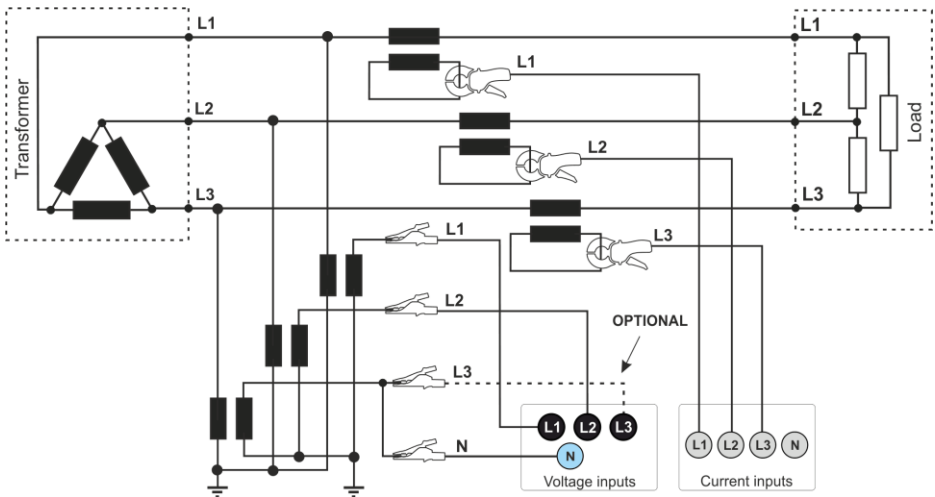

Fig. 13. Wiring diagram – indirect system with transducers – delta configuration.

2.10 Inrush current

This function allows user to record half-period values of voltage and current within 60 sec after starting the measurement. After this time, the measurements are automatically stopped. Before the measurement, set aggregation time at $\frac{1}{2}$ period. Other settings and measurement arrangements are not limited.

2.11 Key Lock

Using the PC program, the user may select an option of locking the keypad after starting the process of recording. This solution is designed to protect the analyzer against unauthorized stopping of the recording process.

To unlock the keys, follow these steps:

- press three times in a row  button in steps of 0.5 s and 1 s,
- then press  button within 0.5 s to 1 s,

When buttons are pressed, the user hears the sounds of inactive buttons – after completing the whole sequence the meter emits a double beep.

2.12 Sleep mode

PC software has the feature that can activate the sleep mode. In this mode, when the user starts recording, the meter turns off LEDs after 10 seconds. From this moment the following options are available:

- immediate triggering – after LEDs are turned off, **LOG** LED blinks every 10 s signalling the recording process,
- triggering by event – after LEDs are turned off, **LOG** LED blinks every 30 s in stand-by mode, and when the recording process starts **LOG** LED starts to blink every 10 s,
- scheduled triggering – after LEDs are turned off, **LOG** LED blinks every 30 s in stand-by mode, and when the recording process starts **LOG** LED starts to blink every 10 s.

2 Operation of the analyzer

In addition to the above cases:

- if the user interrupts the recording process by pressing , then LEDs are lit, unless the next recording is triggered,
- if the analyzer finishes the recording process due to the lack of space on the memory card or due to a completed schedule, the LEDs remain off.

Pressing any button (shortly) activates **ON** LED (and possibly other LEDs e.g. **MEM** depending on the state) and activates desired feature (if available).

2.13 Firmware update

Firmware of the analyzer must be regularly updated in order to correct discovered errors or introduce new functionalities. When the firmware is updated, check whether a new version of *Sonel Analysis* (and vice versa) is available, if yes – proceed with the upgrade.

2.13.1 Automatic update

Automatic update (recommended) is carried out with *Sonel Analysis* software. If the user activates option **Check online updates** in the software settings, the software will connect to the update server during startup. If updates are available, they are displayed (with a list of changes) and the user can confirm their download. The check for updates may be also activated manually by entering the menu and selecting **Help → On-line update**. If the firmware update is available and has been downloaded, you can upgrade the firmware of the meter. To do this:

1. Before starting the update, download all the data from the analyzer to a computer (download and save the recorded data on the disk).
2. Connect the analyzer to the mains for battery charging.
3. Connect the analyzer to the computer via a USB cable and establish a connection between the analyzer and the application. Immediately after connecting, *Sonel Analysis* should display a message about the option of updating the firmware (if the user sets in software options "**Check firmware updates while connecting**").
4. After confirming the update, wait until the process is completed.
5. **NOTE:** After a successful update, it is necessary to program the analyzer at least once before starting recording, in order to avoid inconsistencies in the recorded data.

2.13.2 Manual update

Manual update requires saving the appropriate firmware file on the memory card and starting the update with the button.

1. Before starting the update, download all the data from the analyzer to a computer (download and save the recorded data on the disk).
2. Connect the analyzer to the mains for battery charging.
3. Download a new firmware from the manufacturer's website www.sonel.com. If the file is compressed, extract file FIRMWARE.PQF.
4. FIRMWARE.PQF file must be saved in the root directory of the microSD card using an external card reader.
5. Insert the card into the analyzer. **ON** LED indicates that the firmware file was recognized and readiness to start the update.
6. Press **START**  button to begin the update. If the **START** button is not pressed within 10 seconds, the update is cancelled. The process progress is indicated by blinking LEDs **ON** and **MEM**.
7. **NOTE:** After a successful update, it is necessary to program the analyzer at least once before starting recording, in order to avoid inconsistencies in the recorded data.

3 **"Sonel Analysis" software**

Sonel Analysis is an application required to work with PQM-700 analyzer. It enables the user to:

- configure the analyzer,
- read data from the device,
- real-time preview of the mains,
- delete data in the analyzer,
- present data in the tabular form,
- present data in the form of graphs,
- analysing data for compliance with EN 50160 standard (reports), or other user-defined reference conditions,
- independent operation of multiple devices,
- upgrade the software and the device firmware to newer versions.

Detailed manual for *Sonel Analysis* is available in a separate document (also downloadable from the manufacturer's website www.sonel.com).

4 Design and measurement methods

4.1 Voltage inputs

The voltage input block is shown in Fig. 14. Three phase inputs L1/A, L2/B, L3/C have common reference line, which is the N (neutral) input. Such inputs configuration allows reducing the number of conductors necessary to connect the analyzer to the measured mains. Fig. 14 presents that the power supply circuit of the analyzer is independent of the measuring circuit. The power adapter has a nominal input voltage range 100...415 V AC (140...415 V DC) and has a separate terminals.

The analyzer has one voltage range, with voltage range $\pm 1150V$.

4.2 Current inputs

The analyzer has four independent current inputs with identical parameters. Current transformer (CT) clamps with voltage output in a 1 V standard, or several types of flexible (Rogowski) probes can be connected to each input.

A typical situation is using flexible clamps with built-in electronic integrator. However, the PQM-700 allows connecting the Rogowski coil alone to the input and a digital signal integration.

4.2.1 Digital integrator

The PQM-700 uses the solution with digital integration of signal coming directly from the Rogowski coil. Such approach has allowed the elimination of the analog integrator problems connected with the necessity to ensure declared long-term accuracy in difficult measuring environments. The analog integrators must also include the systems protecting the inputs from saturation in case DC voltage is present on the input.

A perfect integrator has an infinite amplification for DC signals which falls with the rate of 20 dB/decade of frequency. The phase shift is fixed over the whole frequency range and equals -90° .

Theoretically infinite amplification for a DC signal, if present on the integrator input, causes the input saturation near the power supply voltage and makes further operation impossible. In practically implemented systems, a solution is applied which limits the amplification for DC to a specified value, and in addition periodically zeroes the output. There are also techniques of active cancellation of DC voltage which involve its measurement and re-applying to the input, but with an opposite sign, which effectively cancels such voltage. There is a term "leaky integrator" which describes an integrator with finite DC gain. An analog leaky integrator is just an integrator featuring a capacitor shunted with a high-value resistor. Such a system is then identical with a low-pass filter of a very low pass frequency.

Digital integrator implementation ensures excellent long-term parameters – the entire procedure is performed by means of calculations, and aging of components, drifts, etc. have been eliminated. However, just like in the analog version, also here we can find the saturation problem and without a suitable counteraction the digital integration may become useless. It should be remembered that both, input amplifiers and analog-to-digital converters, have a given finite and undesirable offset which must be removed prior to integration. The PQM-700 analyzer firmware includes a digital filter which is to remove totally the DC voltage component. The filtered signal is subjected to digital integration. The resultant phase response has excellent properties, and the phase shift for most critical frequencies 50 and 60 Hz is minimal.

Ensuring the least possible phase shift between the voltage and current components is very important for obtaining small power measurement errors. It can be proven that approximate power

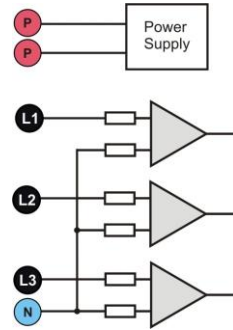

Fig. 14. Voltage Inputs and integrated AC power adapter.

measurement error can be described with the following relationship¹:

$$\text{Power measurement error} \approx \text{phase error (in radians)} \times \tan(\varphi) \times 100\%$$

where $\tan(\varphi)$ is the tangent of the angle between the fundamental voltage and current components. From the formula, it can be concluded that the measurement errors are increasing as the displacement power factor is decreasing; for example, at the phase error of only 0.1° and $\cos\varphi = 0.5$, the error is 0.3%. Anyway, for the power measurements to be accurate, the phase coincidence of voltage and current circuits must be the highest possible.

4.3 Signal sampling

The signal is sampled simultaneously in all eight channels at the frequency synchronized with the frequency of power supply voltage in the reference channel. This frequency equals 10.24 kHz for the 50 Hz and 60 Hz mains systems.

Each period includes then about 205 samples for 50 Hz systems, and about 170 samples for 60 Hz systems. A 16-bit analog-to-digital converter has been used which ensures 64-fold over-sampling.

3-decibel channels attenuation has been specified for frequency of about 12 kHz, and the amplitude error for the 2.4 kHz maximum usable frequency (i.e. the frequency of 40th harmonics in the 60 Hz system) is about 0.3 dB. The phase shift for this frequency is below 15° . Attenuation in the stop band is above 75 dB.

Please note that for correct measurements of phase shift between the voltage harmonics in relation to current harmonics and power of these harmonics, the important factor is not absolute phase shift in relation to the basic frequency, but the phase coincidence of voltage and current circuits. The highest phase difference error for $f = 2.4$ kHz is maximum 15° . Such error is decreasing with the decreasing frequency. Also an additional error caused by used clamps are transducers must be considered when estimating the measurement errors for harmonics power measurements.

4.4 PLL synchronization

The sampling frequency synchronization has been implemented by hardware. After passing through the input circuits, the voltage signal is sent to a band-pass filter which is to reduce the harmonics level and pass only the voltage fundamental component. Then, the signal is sent to the phase locked loop circuits as a reference signal. The PLL system generates the frequency which is a multiple of the reference frequency necessary for clocking of the analog-to-digital converter.

The input voltage range for which the PLL system will work correctly is quite another matter. The 61000-4-7 standard does not give here any concrete indications or requirements. The PQM-700 PLL circuit needs L1-N voltage above 10 V for proper operation.

4.5 Frequency measurement

The signal for measurement of 10-second frequency values is taken from the L1 voltage channel. It is the same signal which is used for synchronization of the PLL. The L1 signal is sent to the 2nd order band pass filter which passband has been set to 40...70 Hz. This filter is to reduce the level of harmonic components. Then, a square signal is formed from such filtered waveform. The signal periods number and their duration is counted during the 10-second measuring cycle. 10-second time intervals are determined by the real time clock (every full multiple of 10-second time). The frequency is calculated as a ratio of counted periods to their duration.

¹ "Current sensing for energy metering", William Koon, Analog Devices, Inc.

4.6 Event detection

The PQM-700 analyzer gives a lot of event detection options in the tested mains system. An event is the situation when the parameter value exceeds the user-defined threshold.

The fact of event occurrence is recorded on the memory card as an entry which includes:

- parameter type,
- channel in which the event occurred,
- times of event beginning and end,
- user-defined threshold value,
- parameter extreme value measure during the event,
- parameter average value measure during the event.

Depending on the parameter type, you can set one, two or three thresholds which will be checked by the analyzer. The table below lists all parameters for which the events can be detected, including specification of threshold types.

Tab. 4. Event threshold types for individual parameters

Parameter	Interruption	Dip	Swell	Minimum	Maximum
U	RMS voltage	•	•	•	
U _{DC}	DC voltage				•
f	Frequency			•	•
CF U	Voltage crest factor			•	•
u ₂	Voltage negative sequence unbalance				•
P _{st}	Short-term flicker P _{st}				•
P _{lt}	Long-term flicker P _{lt}				•
I	RMS current			•	•
CF I	Current crest factor				
i ₂	Current negative sequence unbalance				•
P	Active power			•	•
Q ₁ , Q _B	Reactive power			•	•
S	Apparent power			•	•
D, S _N	Distortion power			•	•
PF	Power factor			•	•
cosφ	Displacement power factor			•	•
tanφ	tanφ (4-quadrant)			•	•
E _{P+} , E _{P-}	Active energy (consumed and supplied)				•
E _{Q+} , E _{Q-}	Reactive energy (consumed and supplied, 4-quadrant)				•
E _S	Apparent energy				•
THD _F U	Voltage THD _F				•
U _{h2..U_{h50}}	Voltage harmonic amplitudes (order n = 2...50)				•
THD _F I	Current THD _F				•
I _{h2..I_{h50}}	Current harmonic amplitudes (order n = 2...50)				•

Some parameters can take positive and negative values. Examples are active power, reactive power, power factor and DC voltage. As the event detection threshold can only be positive, in order to ensure correct detection for above-mentioned parameters, the analyzer compares with the threshold their absolute values.

Example

Event threshold for active power has been set at 10 kW. If the load has a generator character, the active power with correct connection of clamps will be a negative value. If the measured absolute value exceeds the threshold, i.e. 10 kW (for example -11 kW) an event will be recorded – exceeding of the maximum active power.

Two parameter types: RMS voltage and RMS current can generate events for which the user can also have the waveforms record.

The analyzer records the waveforms of active channels (voltage and current) at the event start and end. In both cases, six periods are recorded: two before the start (end) of the event and four after start (end) of the event. The waveforms are recorded in an 8-bit format with 10.24 kHz sampling frequency.

The event information is recorded at its end. In some cases it may happen that event is active when the recording is stopped (i.e. the voltage dip continues). Information about such event is also recorded, but with the following changes:

- no event end time,
- extreme value is only for the period until the stop of recording,
- average value is not given,
- only the beginning waveform is available for RMS voltage or current related events.

In order to eliminate repeated event detection when the parameter value oscillates around the threshold value, the analyzer has a functionality of user-defined event detection hysteresis. It is defined in percent in the following manner:

- for RMS voltage events, it is the percent of the nominal voltage range (for example 2% of 230 V, that is 4.6 V),
- for RMS current events, it is the percent of the nominal current range (for example for C-4 clamps and absence of transducers, the 2% hysteresis equals $0.02 \times 1000 \text{ A} = 20 \text{ A}$),
- for remaining parameters, the hysteresis is specified as a percent of maximum threshold (for example, if the maximum threshold for current crest factor has been set to 4.0, the hysteresis will be $0.02 \times 4.0 = 0.08$).

5 Calculation formulas

5.1 One-phase network

One-phase network			
Parameter			Method of calculation
Name	Designation	Unit	
Voltage (True RMS)	U_A	V	$U_A = \sqrt{\frac{1}{M} \sum_{i=1}^M U_i^2}$ where U_i is a subsequent sample of voltage U_{A-N} $M = 2048$ for 50 Hz and 60 Hz
Voltage DC component	U_{ADC}	V	$U_{ADC} = \frac{1}{M} \sum_{i=1}^M U_i$ where U_i is a subsequent sample of voltage U_{A-N} $M = 2048$ for 50 Hz and 60 Hz
Frequency	F	Hz	number of full voltage periods U_{A-N} counted during 10-sec period (clock time) divided by the total duration of full periods
Current (True RMS)	I_A	A	$I_A = \sqrt{\frac{1}{M} \sum_{i=1}^M I_i^2}$ where I_i is subsequent sample of current I_A $M = 2048$ for 50 Hz and 60 Hz
Current constant component	I_{ADC}	A	$I_{ADC} = \frac{1}{M} \sum_{i=1}^M I_i$ where I_i is a subsequent sample of current I_A $M = 2048$ for 50 Hz and 60 Hz
Active power	P	W	$P = \frac{1}{M} \sum_{i=1}^M U_i I_i$ where U_i is a subsequent sample of voltage U_{A-N} I_i is a subsequent sample of current I_A $M = 2048$ for 50 Hz and 60 Hz
Budeanu reactive power	Q_B	var	$Q_B = \sum_{h=1}^{40} U_h I_h \sin \varphi_h$ where U_h is h -th harmonic of voltage U_{A-N} I_h is h -th harmonic of current I_A φ_h is h -th angle between harmonic U_h and I_h
Reactive power of fundamental component	Q_1	var	$Q_1 = U_1 I_1 \sin \varphi_1$ where U_1 is fundamental component of voltage U_{A-N} I_1 is fundamental component of current I_A φ_1 is angle between fundamental components U_1 and I_1
Apparent power	S	VA	$S = U_{ARMS} I_{ARMS}$
Apparent distortion power	S_N	VA	$S_N = \sqrt{S^2 - (U_1 I_1)^2}$
Budeanu distortion power	D_B	var	$D_B = \sqrt{S^2 - P^2 - Q_B^2}$
Power Factor	PF	-	$PF = \frac{P}{S}$ If $PF < 0$, then the load is of a generator type If $PF > 0$, then the load is of a receiver type

Displacement power factor	$\cos\varphi$ DPF	-	$\cos\varphi = DPF = \cos(\varphi_{U_1} - \varphi_{I_1})$ <p>where φ_{U_1} is an absolute angle of the fundamental component of voltage U_{A-N} φ_{I_1} is an absolute angle of the fundamental component of current I_A</p>
Tangent φ (4-quadrant)	$\tan\varphi_{(L+)}$	-	$\tan\varphi_{(L+)} = \frac{\Delta E_{Q(L+)}}{\Delta E_{P+}}$ <p>where: $\Delta E_{Q(L+)}$ is the increase in reactive energy $E_{Q(L+)}$ (Budeanu/IEEE-1459) in a given averaging period, ΔE_{P+} is the increase in active power taken E_{P+} in a given averaging period</p>
	$\tan\varphi_{(C-)}$	-	$\tan\varphi_{(C-)} = -\frac{\Delta E_{Q(C-)}}{\Delta E_{P+}}$ <p>where: $\Delta E_{Q(C-)}$ is the increase in reactive energy $E_{Q(C-)}$ (Budeanu/IEEE-1459) in a given averaging period, ΔE_{P+} is the increase in active power taken E_{P+} in a given averaging period</p>
	$\tan\varphi_{(L-)}$	-	$\tan\varphi_{(L-)} = \frac{\Delta E_{Q(L-)}}{\Delta E_{P+}}$ <p>where: $\Delta E_{Q(L-)}$ is the increase in reactive energy $E_{Q(L-)}$ (Budeanu/IEEE-1459) in a given averaging period, ΔE_{P+} is the increase in active power taken E_{P+} in a given averaging period</p>
	$\tan\varphi_{(C+)}$	-	$\tan\varphi_{(C+)} = -\frac{\Delta E_{Q(C+)}}{\Delta E_{P+}}$ <p>where: $\Delta E_{Q(C+)}$ is the increase in reactive energy $E_{Q(C+)}$ (Budeanu/IEEE-1459) in a given averaging period, ΔE_{P+} is the increase in active power taken E_{P+} in a given averaging period</p>
Harmonic components of voltage and current	U_{hx} I_{hx}	V A	method of harmonic subgroups according to IEC 61000-4-7 x (harmonic) = 1..50
Total Harmonic Distortion for voltage, referred to the fundamental component	$THDU_F$	-	$THDU_F = \frac{\sqrt{\sum_{h=2}^{40} U_h^2}}{U_1} \times 100\%$ <p>or</p> $THDU_F = \frac{\sqrt{\sum_{h=2}^{50} U_h^2}}{U_1} \times 100\%$ <p>where U_h is h-th harmonic of voltage U_{A-N} U_1 is fundamental component of voltage U_{A-N}</p>
Total Harmonic Distortion for voltage, referred to RMS	$THDU_R$	-	$THDU_R = \frac{\sqrt{\sum_{h=2}^{40} U_h^2}}{U_{ARMS}} \times 100\%$ <p>or</p> $THDU_R = \frac{\sqrt{\sum_{h=2}^{50} U_h^2}}{U_{ARMS}} \times 100\%$ <p>where U_h is h-th harmonic of voltage U_{A-N}</p>

5 Calculation formulas

<p>Total Harmonic Distortion for current, referred to the fundamental component</p>	<p>$THDI_F$</p>	<p>-</p>	$THDI_F = \frac{\sqrt{\sum_{h=2}^{40} I_h^2}}{I_1} \times 100\%$ <p>or</p> $THDI_F = \frac{\sqrt{\sum_{h=2}^{50} I_h^2}}{I_1} \times 100\%$ <p>where I_h is h-th harmonic of current I_A I_1 is fundamental component of current I_A</p>
<p>Total Harmonic Distortion for current, referred to RMS</p>	<p>$THDI_R$</p>	<p>-</p>	$THDI_R = \frac{\sqrt{\sum_{h=2}^{40} I_h^2}}{I_{ARMS}} \times 100\%$ <p>or</p> $THDI_R = \frac{\sqrt{\sum_{h=2}^{50} I_h^2}}{I_{ARMS}} \times 100\%$ <p>where I_h is h-th harmonic of current I_A</p>
<p>TDD factor</p>	<p>TDD</p>	<p>-</p>	$TDD = \frac{\sqrt{\sum_{h=2}^{40} I_h^2}}{I_L} \times 100\%$ <p>where I_h is the h-th harmonic of current I_A I_L is demand current (in automatic mode I_L it is the maximum average value of the fundamental component of current, found in all measured current channels of the entire recording range)</p>
<p>Voltage crest factor</p>	<p>CFU</p>	<p>-</p>	$CFU = \frac{\max U_i }{U_{ARMS}}$ <p>$\max U_i$ Where the operator expresses the highest absolute value of voltage U_{A-N} samples $i = 2048$ for 50 Hz and 60 Hz</p>
<p>Current crest factor</p>	<p>CFI</p>	<p>-</p>	$CFI = \frac{\max I_i }{I_{ARMS}}$ <p>$\max I_i$ Where the operator expresses the highest absolute value of current I_A samples $i = 2048$ for 50 Hz and 60 Hz</p>
<p>Short-term flicker</p>	<p>P_{st}</p>	<p>-</p>	<p>calculated according to IEC 61000-4-15</p>
<p>Long-term flicker</p>	<p>P_{lt}</p>	<p>-</p>	$P_{LT} = \sqrt[3]{\frac{\sum_{i=1}^N P_{STi}^3}{N}}$ <p>where P_{STi} is subsequent i-th indicator of short-term flicker</p>

<p>Active energy (consumed and supplied)</p>	<p>E_{P+} E_{P-}</p>	<p>Wh</p>	$E_{P+} = \sum_{i=1}^M P_+(i)T(i)$ $P_+(i) = \begin{cases} P(i) & \text{for } P(i) > 0 \\ 0 & \text{for } P(i) \leq 0 \end{cases}$ $E_{P-} = \sum_{i=1}^M P_-(i)T(i)$ $P_-(i) = \begin{cases} P(i) & \text{for } P(i) < 0 \\ 0 & \text{for } P(i) \geq 0 \end{cases}$ <p>where: <i>i</i> is subsequent number of the 10/12-period measurement window <i>P</i>(<i>i</i>) represents active power <i>P</i> calculated in <i>i</i>-th measuring window <i>T</i>(<i>i</i>) represents duration of <i>i</i>-th measuring window (in hours)</p>
<p>Reactive energy (4-quadrant)</p>	<p>$E_{Q(L+)}$ $E_{Q(C-)}$ $E_{Q(L-)}$ $E_{Q(C+)}$</p>	<p>varh</p>	$E_{Q(L+)} = \sum_{i=1}^M Q_{L+}(i)T(i)$ $Q_{L+}(i) = Q(i) \text{ if } Q(i) > 0 \text{ i } P(i) > 0$ $Q_{L+}(i) = 0 \text{ in other cases}$ $E_{Q(C-)} = \sum_{i=1}^M Q_{C-}(i)T(i)$ $Q_{C-}(i) = Q(i) \text{ if } Q(i) > 0 \text{ i } P(i) < 0$ $Q_{C-}(i) = 0 \text{ in other cases}$ $E_{Q(L-)} = \sum_{i=1}^M Q_{L-}(i)T(i)$ $Q_{L-}(i) = Q(i) \text{ if } Q(i) < 0 \text{ i } P(i) < 0$ $Q_{L-}(i) = 0 \text{ in other cases}$ $E_{Q(C+)} = \sum_{i=1}^M Q_{C+}(i)T(i)$ $Q_{C+}(i) = Q(i) \text{ if } Q(i) < 0 \text{ i } P(i) > 0$ $Q_{C+}(i) = 0 \text{ in other cases}$ <p>where: <i>i</i> is subsequent number of the 10/12-period measurement window <i>Q</i>(<i>i</i>) represents active power (Budeanu or IEEE1459) calculated in <i>i</i>-th measuring window <i>P</i>(<i>i</i>) represents calculated active power in the <i>i</i>-th measuring window <i>T</i>(<i>i</i>) represents duration of <i>i</i>-th measuring window (in hours)</p>
<p>Apparent energy</p>	<p>E_S</p>	<p>VAh</p>	$E_S = \sum_{i=1}^M S(i)T(i)$ <p>where: <i>i</i> is subsequent number of the 10/12-period measurement window <i>S</i>(<i>i</i>) represents apparent power <i>S</i> calculated in <i>i</i>-th measuring window <i>T</i>(<i>i</i>) represents duration of <i>i</i>-th measuring window (in hours)</p>

5.2 Split-phase network

Split-phase network			
(parameters not mentioned are calculated as for single-phase)			
Parameter			Method of calculation
Name	Designation	Unit	
Total active power	P_{tot}	W	$P_{tot} = P_A + P_B$
Total Budeanu reactive power	Q_{Btot}	var	$Q_{Btot} = Q_{BA} + Q_{BB}$
Total reactive power of fundamental component	Q_{1tot}	var	$Q_{1tot} = Q_{1A} + Q_{1B}$
Total apparent power	S_{tot}	VA	$S_{tot} = S_A + S_B$
Total apparent distortion power	S_{Ntot}	VA	$S_{Ntot} = S_{NA} + S_{NB}$
Total Budeanu distortion power	D_{Btot}	var	$D_{Btot} = D_{BA} + D_{BB}$
Total Power Factor	PF_{tot}	-	$PF_{tot} = \frac{P_{tot}}{S_{tot}}$
Total displacement power factor	$\cos\varphi_{tot}$ DPF_{tot}	-	$\cos\varphi_{tot} = DPF_{tot} = \frac{1}{2}(\cos\varphi_A + \cos\varphi_B)$
Total tangent φ (4-quadrant)	$\tan\varphi_{tot(L+)}$	-	$\tan\varphi_{tot(L+)} = \frac{\Delta E_{Qtot(L+)}}{\Delta E_{Ptot+}}$ where: $\Delta E_{Qtot(L+)}$ is the increase in total reactive energy $E_{Qtot(L+)}$ (Budeanu/IEEE-1459) in a given averaging period, ΔE_{Ptot+} is the increase in total active energy E_{Ptot+} in a given averaging period
	$\tan\varphi_{tot(C-)}$	-	$\tan\varphi_{tot(C-)} = -\frac{\Delta E_{Qtot(C-)}}{\Delta E_{Ptot+}}$ where: $\Delta E_{Qtot(C-)}$ is the increase in total reactive energy $E_{Qtot(C-)}$ (Budeanu/IEEE-1459) in a given averaging period, ΔE_{Ptot+} is the increase in total active energy taken E_{Ptot+} in a given averaging period
	$\tan\varphi_{tot(L-)}$	-	$\tan\varphi_{tot(L-)} = \frac{\Delta E_{Qtot(L-)}}{\Delta E_{Ptot+}}$ where: $\Delta E_{Qtot(L-)}$ is the increase in total reactive energy $E_{Qtot(L-)}$ (Budeanu/IEEE-1459) in a given averaging period, ΔE_{Ptot+} is the increase in total active energy taken E_{Ptot+} in a given averaging period
	$\tan\varphi_{tot(C+)}$	-	$\tan\varphi_{tot(C+)} = -\frac{\Delta E_{Qtot(C+)}}{\Delta E_{Ptot+}}$ where: $\Delta E_{Qtot(C+)}$ is the increase in total reactive energy $E_{Qtot(C+)}$ (Budeanu/IEEE-1459) in a given averaging period, ΔE_{Ptot+} is the increase in total active energy taken E_{Ptot+} in a given averaging period

<p>Total active energy (consumed and supplied)</p>	$\begin{matrix} E_{P_{tot+}} \\ E_{P_{tot-}} \end{matrix}$	<p>Wh</p>	$E_{P_{tot+}} = \sum_{i=1}^M P_{tot+}(i)T(i)$ $P_{tot+}(i) = \begin{cases} P_{tot}(i) & \text{for } P_{tot}(i) > 0 \\ 0 & \text{for } P_{tot}(i) \leq 0 \end{cases}$ $E_{P_{tot-}} = \sum_{i=1}^M P_{tot-}(i)T(i)$ <p>where: <i>i</i> is subsequent number of the 10/12-period measurement window, <i>P_{tot}(i)</i> represents total active power <i>P_{tot}</i> calculated in <i>i</i>-th measuring window <i>T(i)</i> represents duration of <i>i</i>-th measuring window (in hours)</p>
<p>Total reactive energy (4-quadrant)</p>	$\begin{matrix} E_{Q_{tot(L+)}} \\ E_{Q_{tot(C-)}} \\ E_{Q_{tot(L-)}} \\ E_{Q_{tot(C+)}} \end{matrix}$	<p>varh</p>	$E_{Q_{tot(L+)}} = \sum_{i=1}^M Q_{L+}(i)T(i)$ $Q_{L+}(i) = Q(i) \text{ if } Q(i) > 0 \text{ i } P(i) > 0$ $Q_{L+}(i) = 0 \text{ in other cases}$ $E_{Q_{tot(C-)}} = \sum_{i=1}^M Q_{C-}(i)T(i)$ $Q_{C-}(i) = Q(i) \text{ if } Q(i) > 0 \text{ i } P(i) < 0$ $Q_{C-}(i) = 0 \text{ in other cases}$ $E_{Q_{tot(L-)}} = \sum_{i=1}^M Q_{L-}(i)T(i)$ $Q_{L-}(i) = Q(i) \text{ if } Q(i) < 0 \text{ i } P(i) < 0$ $Q_{L-}(i) = 0 \text{ in other cases}$ $E_{Q_{tot(C+)}} = \sum_{i=1}^M Q_{C+}(i)T(i)$ $Q_{C+}(i) = Q(i) \text{ if } Q(i) < 0 \text{ i } P(i) > 0$ $Q_{C+}(i) = 0 \text{ in other cases}$ <p>where: <i>i</i> is subsequent number of the 10/12-period measurement window, <i>Q(i)</i> represents total reactive power (Budeanu or IEEE 1459) calculated in <i>i</i>-th measuring window, <i>P(i)</i> represents total active power calculated in <i>i</i>-th measuring window, <i>T(i)</i> represents duration of <i>i</i>-th measuring window (in hours)</p>
<p>Total apparent energy</p>	$E_{S_{tot}}$	<p>VAh</p>	$E_{S_{tot}} = \sum_{i=1}^M S_{tot}(i)T(i)$ <p>where: <i>i</i> is subsequent number of the 10/12-period measurement window <i>S_{tot}(i)</i> represents total apparent power <i>S_{tot}</i> calculated in <i>i</i>-th measuring window <i>T(i)</i> represents duration of <i>i</i>-th measuring window (in hours)</p>

5.3 3-phase wye network with N conductor

3-phase wye network with N conductor (parameters not mentioned are calculated as for single-phase)			
Parameter			Method of calculation
Name	Designation	Unit	
Total active power	P_{tot}	W	$P_{tot} = P_A + P_B + P_C$
Total Budeanu reactive power	Q_{Btot}	var	$Q_{Btot} = Q_{BA} + Q_{BB} + Q_{BC}$
Total reactive power acc. to IEEE 1459	Q_{I^+}	var	$Q_{I^+} = 3U_1^+ I_1^+ \sin \varphi_1^+$ where: U1+ is the voltage positive sequence component (of the fundamental component) I1+ is the current positive sequence component (of the fundamental component) φ_1^+ is the angle between components U_{I^+} and I_{I^+}
Effective apparent power	S_e	VA	$S_e = 3U_e I_e$ where: $U_e = \sqrt{\frac{3(U_A^2 + U_B^2 + U_C^2) + U_{AB}^2 + U_{BC}^2 + U_{CA}^2}{18}}$ $I_e = \sqrt{\frac{I_A^2 + I_B^2 + I_C^2 + I_N^2}{3}}$
Effective apparent distortion power	S_{eN}	VA	$S_{eN} = \sqrt{S_e^2 + S_{e1}^2}$ where: $S_{e1} = 3U_{e1} I_{e1}$ $U_{e1} = \sqrt{\frac{3(U_{A1}^2 + U_{B1}^2 + U_{C1}^2) + U_{AB1}^2 + U_{BC1}^2 + U_{CA1}^2}{18}}$ $I_{e1} = \sqrt{\frac{I_{A1}^2 + I_{B1}^2 + I_{C1}^2 + I_{N1}^2}{3}}$
Total Budeanu distortion power	D_{Btot}	var	$D_{Btot} = D_{BA} + D_{BB} + D_{BC}$
Total Power Factor	PF_{tot}	-	$PF_{tot} = \frac{P_{tot}}{S_e}$
Total displacement power factor	$\cos \varphi_{tot}$ DPF_{tot}	-	$\cos \varphi_{tot} = DPF_{tot} = \frac{1}{3} (\cos \varphi_A + \cos \varphi_B + \cos \varphi_C)$
Total tangent φ (4-quadrant)	$\tan \varphi_{tot(L^+)}$ $\tan \varphi_{tot(C^-)}$ $\tan \varphi_{tot(L^-)}$ $\tan \varphi_{tot(C^+)}$	-	calculated as for the split-phase network
Total active energy (consumed and supplied)	E_{P+tot} E_{P-tot}	Wh	formula same as in split-phase system
Total reactive energy (4-quadrant)	$E_{Q_{tot}(L^+)}$ $E_{Q_{tot}(C^-)}$ $E_{Q_{tot}(L^-)}$ $E_{Q_{tot}(C^+)}$	varh	calculated as for the split-phase network

Total apparent energy	E_{Stot}	VAh	$E_{Stot} = \sum_{i=1}^M S_e(i)T(i)$ where: i is subsequent number of the 10/12-period measurement window $S_e(i)$ represents the effective apparent power S_e , calculated in i -th measuring window $T(i)$ represents duration of i -th measuring window (in hours)
RMS value of zero voltage sequence	U_0	V	$\underline{U}_0 = \frac{1}{3}(\underline{U}_{A1} + \underline{U}_{B1} + \underline{U}_{C1})$ $U_0 = mag(\underline{U}_0)$ where \underline{U}_{A1} , \underline{U}_{B1} , \underline{U}_{C1} are vectors of fundamental components of phase voltages U_A , U_B , U_C Operator $mag()$ indicates vector module
RMS value of positive voltage sequence	U_1	V	$\underline{U}_1 = \frac{1}{3}(\underline{U}_{A1} + a\underline{U}_{B1} + a^2\underline{U}_{C1})$ $U_1 = mag(\underline{U}_1)$ where \underline{U}_{A1} , \underline{U}_{B1} , \underline{U}_{C1} are vectors of fundamental components of phase voltages U_A , U_B , U_C Operator $mag()$ indicates vector module $a = 1e^{j120^\circ} = -\frac{1}{2} + \frac{\sqrt{3}}{2}j$ $a^2 = 1e^{j240^\circ} = -\frac{1}{2} - \frac{\sqrt{3}}{2}j$
RMS value of negative voltage sequence	U_2	V	$\underline{U}_2 = \frac{1}{3}(\underline{U}_{A1} + a^2\underline{U}_{B1} + a\underline{U}_{C1})$ $U_2 = mag(\underline{U}_2)$ where \underline{U}_{A1} , \underline{U}_{B1} , \underline{U}_{C1} are vectors of fundamental components of phase voltages U_A , U_B , U_C Operator $mag()$ indicates vector module $a = 1e^{j120^\circ} = -\frac{1}{2} + \frac{\sqrt{3}}{2}j$ $a^2 = 1e^{j240^\circ} = -\frac{1}{2} - \frac{\sqrt{3}}{2}j$
Voltage unbalance factor for zero component	u_0	%	$u_0 = \frac{U_0}{U_1} \cdot 100\%$
Voltage unbalance factor for negative sequence	u_2	%	$u_2 = \frac{U_2}{U_1} \cdot 100\%$
Current zero sequence	I_0	A	$\underline{I}_0 = \frac{1}{3}(\underline{I}_{A1} + \underline{I}_{B1} + \underline{I}_{C1})$ $I_0 = mag(\underline{I}_0)$ where \underline{I}_{A1} , \underline{I}_{B1} , \underline{I}_{C1} are vectors of fundamental components for phase currents I_A , I_B , I_C Operator $mag()$ indicates vector module
RMS value of positive current sequence	I_1	A	$\underline{I}_1 = \frac{1}{3}(\underline{I}_{A1} + a\underline{I}_{B1} + a^2\underline{I}_{C1})$ $I_1 = mag(\underline{I}_1)$ where \underline{I}_{A1} , \underline{I}_{B1} , \underline{I}_{C1} are vectors of fundamental current components I_A , I_B , I_C Operator $mag()$ indicates vector module

5 Calculation formulas

RMS value of negative current sequence	I_2	A	$I_2 = \frac{1}{3}(I_{A1} + a^2 I_{B1} + a I_{C1})$ $I_2 = \text{mag}(I_2)$ <p>where I_{A1}, I_{B1}, I_{C1} are vectors of fundamental components for phase voltages I_A, I_B, I_C Operator $\text{mag}()$ indicates vector module</p>
Current unbalance factor for zero sequence	i_0	%	$i_0 = \frac{I_0}{I_1} \cdot 100\%$
Current unbalance factor for negative sequence	i_2	%	$i_2 = \frac{I_2}{I_1} \cdot 100\%$

5.4 3-phase wye and delta network without neutral conductor

3-phase wye and delta network without neutral conductor			
(Parameters: RMS voltage and current, DC components of voltage and current, THD, flicker are calculated as for 1-phase circuits; instead of the phase voltages, phase-to-phase voltages are used. Symmetrical components and unbalance factors are calculated as in 3-phase 4-wire systems.)			
Parameter			Method of calculation
Name	Designation	Unit	
Phase-to-phase voltage U_{CA}	U_{CA}	V	$U_{CA} = -(U_{AB} + U_{BC})$
Current I_2 (Aron measuring circuits)	I_2	A	$I_2 = -(I_1 + I_3)$
Total active power	P_{tot}	W	$P_{tot} = \frac{1}{M} \left(\sum_{i=1}^M U_{iAC} I_{iA} + \sum_{i=1}^M U_{iBC} I_{iB} \right)$ <p>where: U_{iAC} is a subsequent sample of voltage U_{A-C} U_{iBC} is a subsequent sample of voltage U_{B-C} I_{iA} is a subsequent sample of current I_A I_{iB} is a subsequent sample of current I_B $M = 2048$ for 50 Hz and 60 Hz</p>
Total apparent power	S_e	VA	$S_e = 3U_e I_e$ <p>where:</p> $U_e = \sqrt{\frac{U_{AB}^2 + U_{BC}^2 + U_{CA}^2}{9}}$ $I_e = \sqrt{\frac{I_A^2 + I_B^2 + I_C^2}{3}}$
Total reactive power (Budeanu and IEEE 1459)	Q_{tot}	var	$Q = N = \text{sign} \sqrt{S_e^2 - P^2}$ <p>where sign is equal to 1 or -1. The sign is determined basing on the angle of phase shift between standardized symmetrical components of voltages and currents</p>
Total Budeanu distortion power	D_{Btot}	var	$D_{Btot} = 0$
Effective apparent distortion power	S_{eN}	VA	$S_{eN} = \sqrt{S_e^2 + S_{e1}^2}$ <p>where: $S_{e1} = 3U_{e1} I_{e1}$</p>

			$U_{e1} = \sqrt{\frac{U_{AB1}^2 + U_{BC1}^2 + U_{CA1}^2}{9}}$ $I_{e1} = \sqrt{\frac{I_{A1}^2 + I_{B1}^2 + I_{C1}^2}{3}}$
Total Power Factor	PF_{tot}	-	$PF_{tot} = \frac{P_{tot}}{S_e}$
Active energy (consumed and supplied)	$E_{P_{tot+}}$ $E_{P_{tot-}}$	Wh	$E_{p+tot} = \sum_{i=1}^M P_{+tot}(i)T(i)$ $P_{+tot}(i) = \begin{cases} P_{tot}(i) & \text{for } P_{tot}(i) > 0 \\ 0 & \text{for } P_{tot}(i) \leq 0 \end{cases}$ $E_{p-tot} = \sum_{i=1}^M P_{-tot}(i)T(i)$ $P_{-tot}(i) = \begin{cases} P_{tot}(i) & \text{for } P_{tot}(and) < 0 \\ 0 & \text{for } P_{tot}(i) \geq 0 \end{cases}$ <p>where: <i>i</i> is subsequent number of the 10/12-period measurement window $P_{tot}(i)$ represents total active power P_{tot} calculated in <i>i</i>-th measuring window $T(i)$ represents duration of <i>i</i>-th measuring window (in hours)</p>
Total apparent energy	E_{Stot}	VAh	$E_{Stot} = \sum_{i=1}^M S_e(i)T(i)$ <p>where: <i>i</i> is subsequent number of the 10/12-period measurement window $S_e(i)$ represents the total apparent power S_e calculated in <i>i</i>-th measuring window $T(i)$ represents duration of <i>i</i>-th measuring window (in hours)</p>

5.5 Methods of parameter's averaging

Method of averaging parameter	
Parameter	Averaging method
RMS Voltage	RMS
DC voltage	arithmetic average
Frequency	arithmetic average
Crest factor U, I	arithmetic average
Symmetrical components U, I	RMS
Unbalance factor U, I	calculated from average values of symmetrical components
RMS Current	RMS
Active, Reactive, Apparent and Distortion Power	arithmetic average
Power factor PF	calculated from the averaged power values
cosφ	arithmetic average
tanφ	calculated as the ratio of the reactive energy delta (in the related quadrant) to the active energy delta
THD U, I	calculated as the ratio of the average RMS value of the higher harmonics to the average RMS value of the fundamental component (for THD-F), or the ratio of the average of RMS value of higher harmonics to the average value of RMS value (for THD-R)
Harmonic amplitudes U, I	RMS

Note:

RMS average value is calculated according to the formula:

$$RMS = \sqrt{\frac{1}{N} \sum_{i=1}^N x_i^2}$$

The arithmetic average (AVG) is calculated according to the formula:

$$AVG = \frac{1}{N} \sum_{i=1}^N x_i$$

where:

- x_i is subsequent parameter value to be averaged,
- N is the number of values to be averaged.

6 Technical specifications

- Specifications are subject to change without prior notice. Recent revisions of technical documentation are available at www.sonel.com.
- Basic uncertainty is the uncertainty of a measurement instrument at reference conditions specified in Tab. 5.
- Provided uncertainties apply to PQM-700 without additional transformers and clamps.
- Abbreviations:
 - m.v. – reference measured value,
 - U_{nom} – nominal voltage,
 - I_{nom} – nominal current (of clamps),
 - RMS – RMS value,
 - n – harmonic order,
 - s.d. – significant digits (or significant figures) – in reference to resolution of measurement result, the value is recorded with the given number of significant digits, e.g. resolution for 230 V with 4 s.d. will be 0,1 V (notation 230,0 V); resolution for 5 A with 4 s.d. will be 0,001 A (notation 5,000 A),
 - δ_{ph} – additional uncertainty of error in the measurement of the phase between voltage and current harmonics.

6.1 Inputs

Voltage input terminals	
Number of inputs	4 (L1, L2, L3, N - 3 measuring channels)
Maximum input voltage	760 V _{RMS} 40...70 Hz or DC
Measurement category	CAT IV 300 V / CAT III 600 V / CAT II 760 V
Peak input voltage	±1150 V
Analog passband (-3 dB)	12 kHz
Transducers	defined by user
Impedance of measurement inputs	14 MΩ
CMRR	70 dB (50 Hz)

Current input terminals	
Number of inputs	4 (3 phases + neutral) not isolated galvanically
Nominal input voltage (CT clamps)	1 V _{RMS}
Peak input voltage (CT clamps; without ADC overflow)	±3.6 V
Nominal input voltage (flexible clamps)	0.125 V _{RMS}
Peak input voltage (flexible clamps; without ADC overflow)	±0.45 V
Maximum current probes input voltage referred to earth	5 V _{RMS}
Analog passband (-3dB)	12 kHz
Input Impedance	CT clamps: 100 kΩ Flexible clamps: 12.4 kΩ
Measurement range (without transducers)	Flexible probes F-1(A)/F-2(A)/F-3(A): 1..3000 A (±10 kA peak, 50 Hz) Flexible probes F-2AHD/F-3AHD: 1..3000 A (±10 kA peak, 50 Hz) Flexible probes F-1A6/F-2A6/F-3A6: 1..6000 A (±20 kA peak, 50 Hz) Flexible probes F-1A1/F-2A1/F-3A1: 1..1500 A (±5 kA peak, 50 Hz) CT probes C-4(A): 1..1000 A CT probes C-5A: 1..1400 A CT probes C-6(A): 0.01..12 A CT probes C-7(A): 0..100 A
Transformers	defined by user
CMRR	60 dB (50 Hz)

6.2 Sampling and RTC

Sampling and RTC	
A/D converter	16-bit
Sampling rate	10.24 kHz for 50 Hz and 60 Hz Simultaneous sampling in all channels
Samples per period	204.8 for 50 Hz; 170.67 for 60 Hz
PLL synchronization	40..70Hz
Reference channel for PLL	L1/A
Real-time clock	±3.5 ppm max (approx. ± 9 sec./month) in the temperature range of -20°C...+55°C

6.3 Measured parameters - accuracy, resolution and ranges

6.3.1 Reference conditions

Tab. 5. Reference conditions.

Reference conditions	
Ambient temperature	23°C ±2°C
Relative Humidity	40...60%
Voltage unbalance	≤ 0,1% for unbalance factor of negative sequence (applies only to 3-phase systems)
External continuous magnetic field	≤ 40 A / m DC ≤ 3 A / m AC for 50/60 Hz frequency
DC component of voltage and current	none
Waveforms	sinusoidal
Frequency	50 Hz ±0.2% or 60 Hz ±0.2%

6.3.2 Voltage

Voltage	Ranges and conditions	Resolution	Basic uncertainty
U _{RMS} (AC+DC)	20% U _{nom} ≤ U _{RMS} ≤ 120% U _{nom} for U _{nom} ≥ 100 V	4 s.d.	±0.5% U _{nom}
Crest Factor	1..10 (1..1.65 for 690 V voltage) for U _{RMS} ≥ 10% U _{nom}	0.01	±5%

6.3.3 Current

Current	Ranges and conditions	Resolution	Basic uncertainty
I _{RMS} (AC+DC)	Input path without clamps		
	CT line: 0..1 V (±3.6 V max)	4 s.d.	±0.2% I _{nom}
	flexible probes line: 0..125 mV (±450 mV max)		
	Flexible probes F-1(A)/F-2(A)/F-3(A)		
	0..3000 A (±10 kA)	4 s.d.	Additional uncertainty See the probes user manual
	Flexible probes F-2AHD/F-3AHD		
	0..3000 A (±10 kA max)	4 s.d.	Additional uncertainty See the probes user manual
	Flexible probes F-1A6/F-2A6/F-3A6		
	0..6000 A (±20 kA max)	4 s.d.	Additional uncertainty See the probes user manual
	Flexible probes F-1A1/F-2A1/F-3A1		
	0..1500 A (±5 kA max)	4 s.d.	Additional uncertainty See the probes user manual
	CT probes C-4(A)		
	0..1000 A	4 s.d.	Additional uncertainty See the probes user manual
	CT probes C-5A		
0..1400 A	4 s.d.	Additional uncertainty See the probes user manual	
CT probes C-6(A)			
0..12 A	4 s.d.	Additional uncertainty See the probes user manual	
CT probes C-7(A)			
0..100 A	4 s.d.	Additional uncertainty See the probes user manual	
Crest Factor	1..10 (1..3,6 for I _{nom}) for I _{RMS} ≥ 1% I _{nom}	0.01	±5%

6.3.4 Frequency

Frequency	Ranges and conditions	Resolution	Basic uncertainty
f	40..70 Hz $10\% U_{nom} \leq U_{RMS} \leq 120\% U_{nom}$	0.01 Hz	± 0.05 Hz

6.3.5 Harmonics

Harmonics	Ranges and conditions	Resolution	Basic uncertainty
Harmonic (n)	DC, 1..50, grouping: harmonics sub-groups acc. to IEC 61000-4-7		
U_{RMS} amplitude	$0..200\% U_{nom}$	4 s.d.	$\pm 0.15\% U_{nom}$ if m.v. $< 3\% U_{nom}$ $\pm 5\%$ m.v. if m.v. $\geq 3\% U_{nom}$ (acc. to IEC 61000-4-7 Class II)
I_{RMS} amplitude	Depending clamps used (see specifications for I_{RMS})	4 s.d.	$\pm 0.5\% I_{nom}$ if m.v. $< 10\% I_{nom}$ $\pm 5\%$ of m.v. if m.v. $\geq 10\% I_{nom}$ (acc. to IEC 61000-4-7 Class II)
Voltage THD-R (n = 2..40 or n = 2..50)	0.0...100.0% for $U_{RMS} \geq 1\% U_{nom}$	0.1%	$\pm 5\%$
Current THD-R (n = 2..40 or n = 2..50)	0.0...100.0% for $I_{RMS} \geq 1\% I_{nom}$	0.1%	$\pm 5\%$
TDD (n = 2..40)	Depending on I_L	Depending on I_L	Depending on I_L

6.3.6 Power and energy

Power and energy	Conditions (for power and energy $80\% I_{nom} \leq I_{RMS} < 120\% I_{nom}$)	Resolution	Basic uncertainty ⁽¹⁾
Active power Active energy	$2\% I_{nom} \leq I_{RMS} < 5\% I_{nom}$ $\cos\varphi = 1$	4 s.d.	$\sqrt{2.5^2 + A_{ph}^2} \%$
	$5\% I_{nom} \leq I_{RMS} \leq I_{nom}$ $\cos\varphi = 1$		$\sqrt{2.0^2 + A_{ph}^2} \%$
	$5\% I_{nom} \leq I_{RMS} < 10\% I_{nom}$ $\cos\varphi = 0.5$		$\sqrt{2.5^2 + A_{ph}^2} \%$
	$10\% I_{nom} \leq I_{RMS} \leq I_{nom}$ $\cos\varphi = 0.5$		$\sqrt{2.0^2 + A_{ph}^2} \%$
Reactive power Reactive energy	$2\% I_{nom} \leq I_{RMS} < 5\% I_{nom}$ $\sin\varphi = 1$	4 s.d.	$\sqrt{4.0^2 + A_{ph}^2} \%$
	$5\% I_{nom} \leq I_{RMS} < I_{nom}$ $\sin\varphi = 1$		$\sqrt{3.0^2 + A_{ph}^2} \%$
	$5\% I_{nom} \leq I_{RMS} < 10\% I_{nom}$ $\sin\varphi = 0.5$		$\sqrt{4.0^2 + A_{ph}^2} \%$
	$10\% I_{nom} \leq I_{RMS} < I_{nom}$ $\sin\varphi = 0.5$		$\sqrt{3.0^2 + A_{ph}^2} \%$
	$10\% I_{nom} \leq I_{RMS} < I_{nom}$ $\sin\varphi = 0.25$		$\sqrt{4.0^2 + A_{ph}^2} \%$
Apparent power Apparent energy	$2\% I_{nom} \leq I_{RMS} < 5\% I_{nom}$	4 s.d.	$\pm 2.5\%$
	$5\% I_{nom} \leq I_{RMS} \leq I_{nom}$		$\pm 2.0\%$
Power factor (PF)	0...1 $50\% U_{nom} \leq U_{RMS} < 150\% U_{nom}$ $10\% I_{nom} \leq I_{RMS} < I_{nom}$	0.01	± 0.03
Displacement power factor (cos φ /DPF)	0...1 $50\% U_{nom} \leq U_{RMS} < 150\% U_{nom}$ $10\% I_{nom} \leq I_{RMS} < I_{nom}$	0.01	± 0.03

(1) See sec. 6.3.7.

6.3.7 Estimating the uncertainty of power and energy measurements

The total uncertainty of active and reactive power and energy measurements and the harmonics power is based on the following relationship (additional time measurement uncertainty is omitted in case of energy as much smaller than other uncertainty types):

$$\Delta_{P,Q} \cong \sqrt{\Delta_{U_h}^2 + \Delta_{I_h}^2 + \Delta_{ph}^2}$$

where: $\delta_{P,Q}$ – uncertainty of active or reactive power measurement,

δ_{U_h} – total uncertainty of voltage harmonic amplitude measurement (analyzer, transducers),

δ_{I_h} – total uncertainty of current amplitude measurement (analyzer, transducers, clamps),

δ_{ph} – additional uncertainty caused by the error of phase measurement between the voltage and current harmonics.

The δ_{ph} uncertainty can be determined if we know the phase shift angle for a given frequency ranges. Tab. 6 presents the phase difference error between the voltage and current harmonics for the PQM-700 analyzer (without clamps and transducers).

Tab. 6. Phase error in the PQM-700 analyzer depending on the frequency

	Phase difference error				
Frequency range	0..200 Hz	200..500 Hz	500 Hz..1 kHz	1..2 kHz	2..2.4 kHz
Error	≤1°	≤2.5°	≤5°	≤10°	≤15°

The phase error caused by used transducers and clamps can be usually found in their technical documentation. Such being the case, we need to estimate the resultant phase error between the voltage and the current for a given frequency caused by all elements of the measuring circuit: current and voltage transducers, clamps, and the analyzer.

The phase uncertainty of the harmonics active power measurements can be calculated according to the following formula:

$$\delta_{ph} = 100 \left(1 - \frac{\cos(\varphi + \Delta\varphi)}{\cos\varphi} \right) [\%], \cos\varphi \neq 0$$

On the other hand, the phase uncertainty of the harmonics reactive power measurements can be calculated according to the following formula:

$$\delta_{ph} = 100 \left(1 - \frac{\sin(\varphi - \Delta\varphi)}{\sin\varphi} \right) [\%], \sin\varphi \neq 0$$

In both formulas, φ means the actual phase shift angle between the current and voltage components, and $\Delta\varphi$ means the total phase error for a given frequency. The conclusion which can be drawn from these relationships is that power measurement uncertainty for the same phase error very clearly depends on the displacement power factor between current and voltage. It is shown in Fig. 15.

Example

Calculation of measurement uncertainty of active power fundamental component.

Conditions: $\varphi = 60^\circ$, $U_{RMS} \cong U_{nom}$, $I_{RMS} = 5\% I_{nom}$.

Fundamental uncertainty equals

For the 0..200Hz frequency range, the PQM-700 phase error is $< 1^\circ$. After substituting to the equation:

$$\Delta_{ph} = 100 \left(1 - \frac{\cos(\varphi + \Delta\varphi)}{\cos\varphi} \right) = 100 \left(1 - \frac{\cos(61^\circ)}{\cos(60^\circ)} \right) = 3,04\%$$

then, the measurement uncertainty is:

$$\delta = \pm\sqrt{1,0^2 + 3,04^2} = \pm 3,20\%$$

Under the same conditions, but with the phase shift $\varphi = 10^\circ$, we will obtain:

$$\Delta_{ph} = 100 \left(1 - \frac{\cos(11^\circ)}{\cos(10^\circ)} \right) = 0,32\%$$

and the measurement uncertainty is:

$$\delta = \pm\sqrt{1,0^2 + 0,32^2} = \pm 1,05\%$$

The above calculations do not take into account additional errors caused by used clamps and transducers.

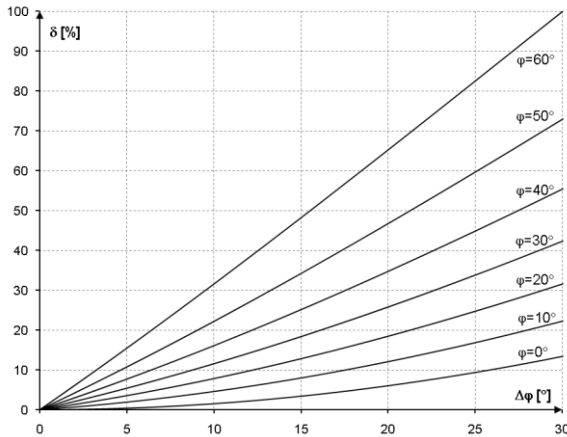

Fig. 15. Additional uncertainty from phase error depending on phase shift angle.

6.3.8 Flicker

Flicker	Ranges and conditions	Resolution	Basic uncertainty
P_{st} (10 min), P_{rk} (2 h)	0.4 ... 10 for $U_{RMS} \geq 80\% U_{nom}$	0.01	$\pm 10\%$ within the values presented in tables of IEC 61000-4-15 standard

6.3.9 Unbalance

Unbalance (voltage and current)	Ranges and conditions	Resolution	Basic uncertainty
Unbalance factor for positive, negative and zero sequence	0.0% ... 10.0% for $80\% U_{nom} \leq U_{RMS} < 150\% U_{nom}$	0.1%	$\pm 0.3\%$ (absolute uncertainty)

6.4 Event detection - voltage and current RMS

U _{RMS} voltage (dips, interruptions and swells)	Range	Resolution	Basic uncertainty
U _{RMS(1/2)}	0.0%...120.0% U _{nom}	4 s.d.	$\pm 1\% U_{nom}$
Detection thresholds	Set by the user in percentage or absolute values. Event detection based on the measurement of U _{RMS(1/2)} (1-period RMS refreshed every ½ period).		
Duration	hh:mm:ss.ms	½ period	One period
Waveform record	Two periods before event + 4 periods after the event (total of 6 cycles) 204.8/170.67 (50 Hz/60 Hz) samples per period		

I _{RMS} current (min, max)	Range	Resolution	Basic uncertainty
I _{RMS(1/2)}	0.0%...100.0% I _{nom}	4 s.d.	$\pm 0.5\% I_{nom}$
Detection thresholds	Set by the user in percentage or absolute values. Event detection based on the measurement of I _{RMS(1/2)} (1-period RMS refreshed every ½ period).		
Duration	hh:mm:ss.ms	½ period	One period
Waveform record	Two periods before event + 4 periods after the event (total of 6 cycles) 204.8/170.67 (50 Hz/60 Hz) samples per period		

6.5 Event detection - other parameters

Parameter	Range	Detection method
Frequency (min, max)	40 ... 70 Hz (percentage or absolute value)	Detection based on 10-sec. measurement (acc. to IEC 61000-4-30)
Voltage crest factor (min, max)	1.0 ... 10.0	Basing on 10/12-period value
Current crest factor (min, max)	1.0 ... 10.0	Basing on 10/12-period value
Negative sequence unbalance factor for voltage (max)	0.0 ... 20.0%	Basing on 10/12-period value
Negative sequence unbalance factor for current (max)	0.0 ... 20.0%	Basing on 10/12-period value
Short-term flicker P _{st} (max)	0..20	Basing on 10-minute value
Long-term flicker P _k (max)	0..20	Basing on 2-hour value
Active power P (min, max)	Depending on the configuration	Basing on 10/12-period value (for consumed and supplied power)
Reactive power Q (min, max)	Depending on the configuration	Basing on 10/12-period value (for consumed and supplied power)
Apparent power S (min, max)	Depending on the configuration	Basing on 10/12-period value
Distortion power D / Apparent distortion power S _N (min, max)	Depending on the configuration	Basing on 10/12-period value
Power Factor PF (min, max)	0...1	Basing on 10/12-period value
Displacement power factor cosφ/DPF (min, max)	0...1	Basing on 10/12-period value
4-quadrant tanφ (min, max)	0...10	Basing on 10/12-period value

6 Technical specifications

Active energy E_P (max)	Depending on the configuration	Exceedance checked every 10/12 periods (for consumed and supplied energy)
4-quadrant reactive energy E_Q (max)	Depending on the configuration	Exceedance checked every 10/12 periods (for consumed and supplied energy)
Apparent energy E_S (max)	Depending on the configuration	Exceedance checked every 10/12 periods
Total harmonic distortion for voltage THD-F (max)	0...100%	Basing on 10/12-period value
Total harmonic distortion for current THD-F (max)	0...200%	Basing on 10/12-period value
Voltage harmonic amplitudes (max)	0 ... 100% or absolute values	Basing on 10/12-period value; Independent thresholds for all harmonics in the range of 2 ... 40
Current harmonic amplitudes (max)	0...200% or absolute values	Basing on 10/12-period value; Independent thresholds for all harmonics in the range of 2 ... 40

6.5.1 Event detection hysteresis

Event detection hysteresis	Range	Calculation method
Hysteresis	0..10% in 0.1% steps	See section 4.6.

6.6 Inrush current measurement

Range [A,%]	Resolution [A,%]	Basic uncertainty
0...100% I_{nom}	4 s.d.	$\pm 0.5\% I_{nom}$

- voltage and current measurement is carried out every $\frac{1}{2}$ period in all channels (averaging set to $\frac{1}{2}$ period)
- measurement time up to 60 seconds.

6.7 Recording

Recorder	
Averaging time ⁽¹⁾	1 s, 3 s, 10 s, 30 s, 1 min, 5 min, 10 min, 15 min, 30 min. Special mode: $\frac{1}{2}$ period (for recording waveforms with a limited recording time up to 60 sec, e.g. inrush current) ⁽²⁾
Averaging min / max for U_{RMS}	$\frac{1}{2}$ period, period, 200 ms, 1 s, 3 s, 5 s ⁽³⁾
Averaging min / max for I_{RMS}	$\frac{1}{2}$ period, period, 200 ms, 1 s, 3 s, 5 s ⁽³⁾
Waveforms	Event waveforms for voltage and current
Recording activation mode	manual starting at the first detected event scheduled (four defined time periods)
Measurement points	1, single user configuration
Recording time	Depending on the configuration
Memory	Built-in 2 GB micro-SD memory card
Memory Model	Linear
Security	Key lock to prevent unauthorized access

(1) Averaging times shorter than 10 seconds are in fact equal to a multiple of the mains period:
200 ms = 10/12 cycles, 1 s = 50/60 periods, 3 s = 150/180 periods, 5 s = 250/300 cycles.

(2) $U_{RMS(1/2)}$ and $I_{RMS(1/2)}$ are RMS values for one period, refreshed every half period.

(3) Averaging periods min./max. 200 ms, 1 s, 3 s, 5 s are in fact equal to a multiple of the mains period: 200 ms = 10/12 cycles, 1 s = 50/60 periods, 3 s = 150/180 periods, 5 s = 250/300 cycles

Recorded parameters	Mean value	Minimum value	Maximum value	Instantaneous value
RMS phase/phase-to-phase (depending on the type of system) voltage U_{RMS}	•	•	•	•
RMS phase-to-phase voltage U_{RMS} (only 3-phase wye with N and split-phase systems)	•			
RMS current I_{RMS}	•	•	•	•
Frequency f	•	•	•	•
Voltage crest factor CF U	•	•	•	•
Current crest factor CF I	•	•	•	•
Unbalance factors for negative and positive sequence, symmetrical components: negative, positive, zero (voltage) $U_{0-}, U_{1-}, U_{2-}, U_{0+}, U_{2+}$	•	•	•	•
Unbalance factors for negative and positive sequence, symmetrical components: negative, positive, zero (current) $I_{0-}, I_{1-}, I_{2-}, I_{0+}, I_{2+}$	•	•	•	•
Flicker factor P_{st} and P_{it}	•	•	•	•
Active power (consumed and supplied) P_{+}, P_{-}	•	•	•	•
Reactive power (consumed and supplied) $Q_{1+}, Q_{1-} / Q_{B+}, Q_{B-}$	•	•	•	•
Apparent power S	•	•	•	•
Distortion power D / Apparent distortion power S_N	•	•	•	•
Power factor PF	•	•	•	•
Displacement power factor $\cos\phi$ /DPF	•	•	•	•
$\tan\phi$ factor (4 quadrants): $\tan\phi(L-), \tan\phi(C-), \tan\phi(L+), \tan\phi(C+)$	•	•	•	•
Active energy (consumed and supplied) E_{P+}, E_{P-}				•
Reactive energy (4 quadrants) $E_{Q(L-)}, E_{Q(C-)}, E_{Q(L+)}, E_{Q(C+)}$				•
Apparent energy E_S				•
Total harmonic distortion for Voltage THD-F	•	•	•	•
Total harmonic distortion for current THD-F	•	•	•	•
TDD factor	•			
Voltage harmonic amplitudes $U_{h1} \dots U_{h50}$	•	•	•	•
Current harmonic amplitudes $I_{h1} \dots I_{h50}$	•	•	•	•

6.8 Power supply, battery and heater

Power supply											
Input voltage range	100...415 V AC, 40...70 Hz 140...415 V DC										
Input voltage range (including fluctuations)	90...460 V AC, 40...70 Hz 127...460 V DC										
Oversvoltage category	Altitude up to 4000 m: CAT IV 300 V / CAT III 415 V / CAT III 460 V (including fluctuations) Altitude 4000-5000 m: CAT III 300 V / CAT II 415 V / CAT II 460 V (including fluctuations)										
Power consumption	max. 30 VA										
Power consumption from mains depending on configuration (typical)	<table border="0"> <tr> <td>no battery charging, heater disabled, supply voltage 230 V AC</td> <td>6 VA / 3 W</td> </tr> <tr> <td>no battery charging, heater enabled, supply voltage 230 V AC</td> <td>11 VA / 8 W</td> </tr> <tr> <td>with battery charging, heater disabled, supply voltage 230 V AC</td> <td>14 VA / 11 W</td> </tr> <tr> <td>with battery charging, heater enabled, supply voltage 230 V AC</td> <td>22 VA / 16 W</td> </tr> <tr> <td>with battery charging, heater enabled, supply voltage 400 V AC</td> <td>27 VA / 16 W</td> </tr> </table>	no battery charging, heater disabled, supply voltage 230 V AC	6 VA / 3 W	no battery charging, heater enabled, supply voltage 230 V AC	11 VA / 8 W	with battery charging, heater disabled, supply voltage 230 V AC	14 VA / 11 W	with battery charging, heater enabled, supply voltage 230 V AC	22 VA / 16 W	with battery charging, heater enabled, supply voltage 400 V AC	27 VA / 16 W
no battery charging, heater disabled, supply voltage 230 V AC	6 VA / 3 W										
no battery charging, heater enabled, supply voltage 230 V AC	11 VA / 8 W										
with battery charging, heater disabled, supply voltage 230 V AC	14 VA / 11 W										
with battery charging, heater enabled, supply voltage 230 V AC	22 VA / 16 W										
with battery charging, heater enabled, supply voltage 400 V AC	27 VA / 16 W										

Rechargeable battery	
Type	Li-Ion 4.4 Ah
Operating time on battery	> 6 h
Battery charging time (fully discharged battery)	< 8 h
Charging temperature range	-10°C ... +60°C
Current consumption from battery in analyzer off mode (mains power disconnected)	< 1 mA

Heater	
Heater temperature threshold (activation)	+5°C
Heater power supply	from internal AC/DC adapter
Heater power	max. 5 W

6.9 Supported networks

Types of supported networks (directly and indirectly)	
1-phase	1-phase with a neutral conductor (terminals: L1/A, N)
2-phase (split-phase)	Split phase with a neutral conductor (terminals: L1/A, L2/B, N)
3-phase wye with N,	3-phase wye with a neutral conductor (terminals: L1/A, L2/B, L3/C, N)
3-phase delta	Three-phase delta (terminals: L1/A, L2/B, L3/C, N shorted with L3/C)
3-phase delta (Aron)	Three-phase delta (terminals: L1/A, L2/B, L3/C, N shorted with L3/C) with two current clamps
3-phase wye without N,	3-phase wye without neutral conductor (terminals: L1/A, L2/B, L3/C, N shorted with L3/C)
3-phase wye without N (Aron)	3-phase wye without neutral conductor (terminals: L1/A, L2/B, L3/C, N shorted with L3/C) with two current clamps

6.10 Supported current probes

Types of supported current clamps	
F-1(A)	Flexible probes (Rogowski coil), perimeter: 120 cm, measuring range 3000 A _{RMS}
F-2(A)	Flexible probes (Rogowski coil), perimeter: 80 cm, measuring range 3000 A _{RMS}
F-3(A)	Flexible probes (Rogowski coil), perimeter: 45 cm, measuring range 3000 A _{RMS}
F-2AHD	Flexible probes (Rogowski coil), perimeter: 91,5 cm, measuring range 3000 A _{RMS}
F-3AHD	Flexible probes (Rogowski coil), perimeter: 45 cm, measuring range 3000 A _{RMS}
F-1A6	Flexible probes (Rogowski coil), perimeter: 120 cm, measuring range 6000 A _{RMS}
F-2A6	Flexible probes (Rogowski coil), perimeter: 80 cm, measuring range 6000 A _{RMS}
F-3A6	Flexible probes (Rogowski coil), perimeter: 45 cm, measuring range 6000 A _{RMS}
F-1A1	Flexible probes (Rogowski coil), perimeter: 120 cm, measuring range 1500 A _{RMS}
F-2A1	Flexible probes (Rogowski coil), perimeter: 80 cm, measuring range 1500 A _{RMS}
F-3A1	Flexible probes (Rogowski coil), perimeter: 45 cm, measuring range 1500 A _{RMS}
C-4(A)	CT, AC probes, measuring range 1000 A _{RMS}
C-5A	CT, AC/DC probes with Hall sensor, measuring range 1400 A _{RMS}
C-6(A)	CT, AC probes for low currents, measuring range 12 A _{RMS}
C-7(A)	CT, AC probes, measuring range 100 A _{RMS}

NOTE: Clamps with letter 'A' in the marking (e.g. F-3A) are clamps with automatic type detection in compatible devices. Other parameters are the same as in the case of clamps without automatic clamp type detection. Automatic clamp type detection is available in analyzers: PQM-700 with HWc hardware and later and with firmware 1.30 or later.

6.11 Communication

Communication	
USB	Max. bitrate: 921.6 kbit/s, Compatible with USB 2.0

6.12 Environmental conditions and other technical data

Environmental conditions	
Operating temperature range:	-20°C...+55°C
Storage temperature range	-30°C...+60°C
Humidity	10...90% with possible condensation
Operating altitude	up to 4000 m (4000-5000 m with derated measurement category CAT III 300 V / CAT II 600 V)
Ingress protection (according to IEC 60529)	IP65 (not evaluated by UL)
Wet location	No
Reference conditions	Ambient temperature: 23°C ±2°C Humidity: 40...60%
Dimensions	200 x 180 x 77 mm (without cables)
Weight	approx. 1.6 kg
Display	5 LEDs indicating operational status
Data memory	removable microSD memory card (2 GB as standard) option of extending up to 32 GB (optional).

6.13 Safety and electromagnetic compatibility

Safety and EMC	
Compliance with	IEC 61010-1, 3 rd Edition
Measurement Category (Voltage measurement inputs)	Altitude up to 4000 m: IV 300 V / III 600 V / II 760 V Altitude 4000-5000 m: III 300 V / II 600 V pollution class 2
Overvoltage Category (AC/DC Power adapter)	Altitude up to 4000 m: IV 300 V / III 415 V / III 460 V (including fluctuations) Altitude 4000-5000 m: III 300 V / II 415 V / II 460 V (including fluctuations) pollution class 2
Insulation	Double acc. to IEC 61010-1
Electromagnetic compatibility	IEC 61326
Immunity to radio frequency interferences	IEC 61000-4-3 sinusoidal modulation 80% AM, 1 kHz 80...1000 MHz, 10 V/m 1.4...2.0 GHz, 3 V/m 2.0... 2.7 GHz, 1 V/m
Immunity to electrostatic discharge	IEC 61000-4-2 Air discharge: 8 kV Contact discharge: 4 kV
Immunity to conducted disturbances, induced by radio-frequency fields	IEC 61000-4-6 sinusoidal modulation 80% AM, 1 kHz 0.15...80 MHz, 10 V
Immunity to a series of electrical fast transients/bursts	IEC 61000-4-4 Amplitude of 2 kV, 5 kHz
Surge immunity	IEC 61000-4-5 Amplitude 2 kV (L-L)
Emission of radiated RF disturbances	IEC 61000-6-3 30...230 MHz, 30 dB(μV/m) at 10 m 230...1000 MHz, 37 dB(μV/m) at 10 m
Emissions of conducted interferences	IEC 61000-6-3 Levels for a quasi-peak detector: 0.15 kHz...0.5 MHz: 66 dBμV...56 dBμV 0.5 MHz...5 MHz: 56 dBμV 5 MHz...30 MHz: 60 dBμV

6.14 Standards

Standards	
Measurement methods	IEC 61000-4-30 Class S
Measurement accuracy	IEC 61000-4-30 Class S
Power Quality	EN 50160
Flicker	IEC 61000-4-15
Harmonics	IEC 61000-4-7
Safety	IEC 61010
EMC	IEC 61326
Quality standard	design, construction and manufacturing are ISO 9001 compliant

7 Cleaning and maintenance

Note

Use only the maintenance methods presented by the manufacturer in this manual.

Clean the analyzer casing with a wet cloth, using generally available detergents. Do not use any solvents and cleaning media which could scratch the casing (powder, paste, etc.).

Clean the leads can with water and detergents, then wipe dry.

The analyzer electronic system is maintenance free.

8 Storage

When storing the device, observe the following recommendations:

- disconnect all leads from the analyzer,
- thoroughly clean the analyzer and all accessories,
- recharge the battery from time to time to prevent total discharging.

9 Dismantling and disposal

Used electric and electronic equipment should be collected selectively, i.e. not placed with other types of waste.





Used electronic equipment shall be sent to the collection point according to the Used Electric and Electronic Equipment Act.





Before sending the instrument to the collection point, do not dismantle any parts by yourself.

Observe local regulations on disposal of packages and used batteries.

10 Optional accessories

- The parameters apply to clamps currently on offer. For the parameters of all clamps in a given series, please refer to the user manual of the respective accessory.
- The full list of accessories can be found on the manufacturer's website.

				
	C-4A	C-5A	C-6A	C-7A
	WACEGC4AOKR	WACEGC5AOKR	WACEGC6AOKR	WACEGC7AOKR
Rated current	1000 A AC	1000 A AC 1400 A DC	12 A AC	100 A AC
Frequency	30 Hz...5 kHz	DC...5 kHz	40 Hz...10 kHz	40 Hz...1 kHz
Max. diameter of measured conductor	52 mm	39 mm	20 mm	24 mm
Minimum accuracy	≤0.5%	≤1.5%	≤1%	0,5%
Battery power	—	√	—	—
Lead length	2.2 m	2.2 m	2.2 m	3 m
Measurement category	III 600 V IV 300 V	IV 300 V	III 600 V IV 300 V	III 300 V
Ingress protection	IP40			

					
	F-1A1 / F-1A / F-1A6	F-2A1 / F-2A / F-2A6	F-3A1 / F-3A / F-3A6	F-2AHD	F-3AHD
	WACEGF1A1OKR WACEGF1AOKR WACEGF1A6OKR	WACEGF2A1OKR WACEGF2AOKR WACEGF2A6OKR	WACEGF3A1OKR WACEGF3AOKR WACEGF3A6OKR	WACEGF2AHDOKR	WACEGF3AHDOKR
Rated current	1500 / 3000 / 6000 A AC	1500 / 3000 / 6000 A AC	1500 / 3000 / 6000 A AC	3000 A AC	
Frequency	40 Hz...10 kHz			10 Hz...20 kHz	
Max. diameter of measured conductor	380 mm	250 mm	140 mm	290 mm	145 mm
Minimum accuracy	0.5%			0.5%	
Battery power	—			—	
Lead length	2.5 m			2.5 m	
Measurement category	III 1000 V IV 600 V			III 1000 V IV 600 V	
Ingress protection	IP67			IP65	

11 Manufacturer

The manufacturer of the device and provider of guarantee and post-guarantee services:

SONEL S.A.
Wokulskiego 11
58-100 Świdnica
Poland
tel. +48 74 884 10 53 (Customer Service)
e-mail: customerservice@sonel.com
web page: www.sonel.com

Note

Service repairs must be performed only by the manufacturer.

NOTES

NOTES



SONEL S.A.

Wokulskiego 11
58-100 Świdnica
Poland

Customer Service

tel. +48 74 884 10 53
e-mail: customerservice@sonel.com

www.sonel.com