

USER MANUAL

POWER QUALITY ANALYZERS

**PQM-702 • PQM-702T • PQM-703
PQM-710 • PQM-711**



USER MANUAL

POWER QUALITY ANALYZERS

PQM-702
PQM-702T
PQM-703
PQM-710
PQM-711



SONEL S.A.
Wokulskiego 11
58-100 Świdnica
Poland

CONTENTS

1	General information	6
1.1	Safety	6
1.2	General characteristics	8
1.3	Power supply of the analyzer	11
1.4	Tightness and outdoor operation	12
1.5	Mounting the fasteners	13
1.6	Mounting on DIN rail	14
1.7	Measured parameters	15
2	Operation of the analyzer	17
2.1	Buttons	17
2.2	Switching the analyzer ON/OFF	17
2.3	Auto-off	17
2.4	Screens	18
2.5	Verifying the connection	23
2.6	"Sonel Analysis" software	24
2.7	PC connection and data transmission	24
2.7.1	USB communication	25
2.7.2	Radio communication via OR-1	PQM-702 PQM-702T PQM-703 26
2.7.3	Communication via GSM network	26
2.7.4	Radio communication via Wi-Fi	PQM-710 PQM-711 27
2.8	Taking measurements	28
2.8.1	Measurement Points	28
2.8.2	Start / stop of recording	29
2.8.3	Recording configuration	29
2.8.4	Approximate recording times	30
2.9	Measuring circuits	32
2.10	Inrush current	39
2.11	Example of use	40
2.12	Time Synchronization	45
2.12.1	Requirements of IEC 61000-4-30	45
2.12.2	GPS receiver	45
2.12.3	Data flagging concept	45
2.12.4	Time resynchronization	46
2.13	GSM communication mode	47
2.13.1	General information about GSM connection	47
2.13.2	Modem Configuration	47
2.13.3	Checking GSM connection	49
2.13.4	Possible problems with GSM settings and troubleshooting	50
2.14	Wi-Fi communication mode	PQM-710 PQM-711 52
2.14.1	General Information	52
2.14.2	Factory configuration	52
2.14.3	Access Point mode	52
2.14.4	Client mode	55
2.14.5	Checking Wi-Fi connection	59
2.14.6	Possible problems with Wi-Fi and troubleshooting	60
2.15	Notification of analyzer changed location	61
2.16	Key lock	62
2.17	LCD sleep mode	62









2.18	Temperature protection	62
2.19	Emergency time setting	63
3	Design and measurement methods	64
3.1	Voltage inputs	64
3.2	Current inputs	64
3.3	Digital integrator	64
3.4	Signal sampling	65
3.5	PLL synchronization	65
3.6	Frequency measurement	66
3.7	Measurement of ripple control signals	66
3.8	Measurement of transients PQM-703 PQM-711	66
3.8.1	Threshold method	68
3.8.2	Slew rate (dV/dt) method	68
3.9	Current limiting function	69
3.10	Event detection	70
3.10.1	Waveshape variation events	72
3.10.2	Phase jump events	72
3.10.3	Rapid Voltage Changes (RVC) events	72
3.11	Methods of parameter's averaging	73
4	Calculation formulas	74
4.1	One-phase network	74
4.2	Split-phase network	78
4.3	3-phase wye network with N conductor (3-phase, 4-wire)	80
4.4	3-phase wye without N conductor and delta networks	82
5	Technical data	84
5.1	Inputs	84
5.2	Sampling and RTC	85
5.3	Transient module PQM-703 PQM-711	85
5.4	Measured parameters - accuracy, resolution and ranges	86
5.4.1	Reference conditions	86
5.4.2	The measurement uncertainty due to ambient temperature	86
5.4.3	Voltage	86
5.4.4	Current	87
5.4.5	Frequency	87
5.4.6	Harmonics	88
5.4.7	Interharmonics	88
5.4.8	Harmonic Powers	88
5.4.9	Power and energy	89
5.4.10	Estimating measurement uncertainty values for power and energy	89
5.4.11	Flicker	91
5.4.12	Unbalance	91
5.4.13	Mains signalling	91
5.4.14	Transients PQM-703 PQM-711	92
5.4.15	External temperature PQM-702T	92
5.5	Event detection - dips, swells, interruptions, RVC, RMS current	92
5.6	Event detection - other parameters	93
5.6.1	Event detection hysteresis	94
5.7	Recording	94
5.8	Power supply, battery, heater	96

5.9	<i>Supported mains types</i>	97
5.10	<i>Supported current probes</i>	97
5.11	<i>Communication</i>	98
5.12	<i>Environmental conditions and other technical data</i>	98
5.13	<i>Safety and electromagnetic compatibility</i>	99
5.14	<i>Standards</i>	100
5.14.1	<i>Compliance with standards</i>	100
5.14.2	<i>Product specification according to IEC 62586</i>	102
6	<i>Cleaning and maintenance</i>	103
7	<i>Storage</i>	103
8	<i>Dismantling and utilization</i>	103
9	<i>Optional accessories</i>	104
10	<i>Manufacturer</i>	105

1 General information

PQM-711 *The icon with the analyzer name is placed next to sections of the text that refer to specific features of the analyzer, particularly to availability/unavailability of a given function. All other parts of the text relate to all types of the analyzer.*

The following international symbols are used on the analyzer and in this manual:

	Warning; See explanation in manual		Functional earth terminal		Alternating voltage/ current
	Direct voltage/ current		Double Insulation (Protection Class)		Conforms to relevant European Union direc- tives (<i>Conformité Européenne</i>)
	Do not dispose of this product as un- sorted municipal waste		Recycling information		Conforms to relevant Australian standards

1.1 Safety



To avoid electric shock or fire, you must observe the following guidelines:

- Before you proceed to operate the analyzer, acquaint yourself thoroughly with the present manual and observe the safety regulations and specifications provided by the producer.
- Any application that differs from those specified in the present manual may result in damage to the device and constitute a source of danger for the user.
- Analyzers must be operated only by appropriately qualified personnel with relevant certificates authorizing the personnel to perform works on electric systems. Operating the analyzer by unauthorized personnel may result in damage to the device and constitute a source of danger for the user.
- The device must not be used for networks and devices in areas with special conditions, e.g. fire-risk and explosive-risk areas.
- Before starting the work, check the analyzer, wires, current probes and other accessories for any sign of mechanical damage. Pay special attention to the connectors.
- It is unacceptable to operate the device when:
 - ⇒ it is damaged and completely or partially out of order,
 - ⇒ its cords and cables have damaged insulation,
 - ⇒ of the device and accessories mechanically damaged.
- Do not power the analyzer from sources other than those listed in this manual.
- Do not connect inputs of the analyzer to voltages higher than the rated values.

1 General information

- Use accessories and probes with a suitable rating and measuring category for the tested circuit.
- Do not exceed the rated parameters of the lowest measurement category (CAT) of the used measurement set consisting of the analyzer, probes and accessories. The measurement category of the entire set is the same as of the component with the lowest measurement category.
- If possible, connect the analyzer to the de-energized circuits.
- Use the PE (earth) terminal only for connecting the local ground, do not connect it to any voltage.
- Opening the device socket plugs results in the loss of its tightness, leading to a possible damage in adverse weather conditions. It may also expose the user to the risk of electric shock.
- Do not handle or move the device while holding it only by its cables.
- Do not unscrew the nuts from the cable glands, as they are permanently fixed. Unscrewing the nuts will void the guarantee.
- **PQM-702T** It is not allowed to mount ST-2 temperature probe on objects with voltage higher than 50 V to earth. It is advisable to ground the examined object before mounting the probe.
- Repairs may be performed only by an authorized service point.

The analyzer is equipped with an internal Li-Ion battery, which has been tested by an independent laboratory and is quality-certified for compliance with the standard *UN Manual of Tests and Criteria Part III Subsection 38.3 (ST/SG/AC.10/11/Rev.5)*. Therefore, the analyzer is approved for air, maritime and road transport.

1.2 General characteristics

Power Quality Analyzers PQM-702(T), PQM-703, PQM-710 and PQM-711 (Fig. 1) are high-tech devices providing their users with a comprehensive features for measuring, analyzing and recording parameters of 50/60 Hz power networks and power quality in accordance with the European Standard EN 50160. Analyzers are fully compliant with the requirements of IEC 61000-4-30:2015, Class A.

The device is equipped with five voltage measurement inputs installed as cables terminated with banana plugs marked as L1/A, L2/B, L3/C, N and PE (ground). The range of voltages measured by four measurement channels is up to 760 V_{RMS} or 1000 V_{RMS} referred to ground (depending on rating). This range may be increased by using additional external voltage transformers.

Measurements are carried out using four current inputs installed on short cables terminated with probe terminals. The terminals may be connected to the following probe types: flexible probes with nominal rating up to 6000 A and hard clamps. Also in case of current, the nominal range may be changed by using additional transformers.

The device has a built-in 8 GB memory card. To guarantee fast data read-out, the analyzer is equipped with a built-in mass-storage reader, which ensures the data readout with a few MB/s. Data read-out may be also be carried out by one of the available communication links: USB, OR-1 radio receiver (PQM-702(T) and PQM-703 only), Wi-Fi (PQM-710 and PQM-711 only) and GSM modem.

The device is provided with a built-in GSM modem and an antenna. This solution provides it with almost unrestricted access to the analyzer from any chosen global location with available GSM network. On the left side of its housing the analyzer has a SIM card, which is required for data transmission via GSM networks.

Another advantage of the device is a built-in GPS receiver with antenna, making the analyzer fully compliant with the requirements of IEC 61000-4-30 Class A, without the need of installing additional accessories. The GPS receiver ensures the synchronization with UTC (Universal Time Clock), and provides measurement accuracy of tens of nanoseconds. GPS receivers may receive satellite signals in the open air; therefore synchronization with a built-in antenna is possible only outside of buildings. When the analyzer is used indoors, in order to ensure the availability of the GPS signal, the device should be connected to an external GPS antenna (cable length: 10 m) located outside the building. External antenna is an additional accessory.

Tab. 1. Main differences between analyzers

	PQM-702	PQM-702T	PQM-703	PQM-710	PQM-711
Transient module			•		•
433 MHz radio interface (with OR-1 receiver)	•	•	•		
Wi-Fi radio interface				•	•
External temperature measurement (with ST-2 probe)		•			

1 General information

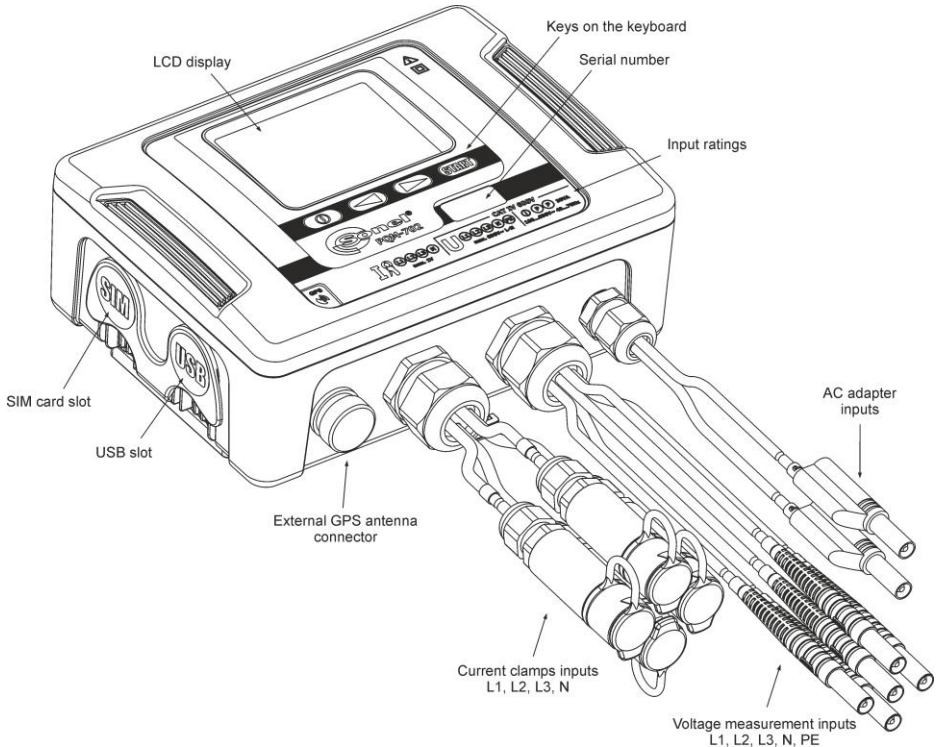

Fig. 1. Power Quality Analyzer. General view.

Recorded parameters are divided into groups that may be independently turned on/off for recording purposes and this solution facilitates the rational management of the space on the memory card. Parameters that are not recorded, leave more memory space for further measurements.

PQM-702T PQM-702T power supply quality analyzer is a variant of PQM-702 analyzer and it additionally enables measurements of the temperature of external objects with ST-2 probe (standard accessory). Other capabilities and functions of PQM-702T analyzer are the same as in PQM-702.

The terminal for connecting the probe is in the pass together with current probe terminals and it is marked with the letter "T".

Unless stated otherwise, in the following part of the manual, all sections referring to PQM-702 analyzer also apply to PQM-702T.

The analyzer has an internal power supply adapter operating in a wide input voltage range 100...690 V AC (140...690 V DC), which is provided with independent cables terminated with banana plugs.

An important feature of the device is its ability to operate in harsh weather conditions - the analyzer may be installed directly on electric poles. The ingress protection class of the analyzer is IP65, and operating temperature ranges from -20°C to +55°C.

Uninterrupted operation of the device (in case of power failure) is ensured by an internal rechargeable lithium-ion battery.

The user interface includes a color 3.5" LCD display with a resolution of 320x240 pixels and a keypad with four buttons.

The full potential of the device may be released by using dedicated PC software "Sonel Analysis".

The analyzer may communicate with a PC in the following ways:

- via USB connection with a transmission speed up to 921.6 kbit/s; available data reading from a memory card with a speed of a few MB/s,
- **PQM-702 PQM-703** via radio interface – using OR-1 receiver with a transmission rate of 57.6 kbit/s (range limited to approx. 5 m),
- **PQM-710 PQM-711** via Wi-Fi radio interface with effective transmission rate up to 300 kB/s (max. sustained speed in a 10 m distance),
- via GSM connection using the Internet.

PQM-702 PQM-703 In order to use the first mode of wireless communication, OR-1 receiver must be connected to a PC using its USB port. Communication in this mode is slower, therefore we recommend it to view current (live) parameters of the measured network and to configure and control the analyzer. It is not recommended to read a large amount of data stored on the memory card via a radio link, due to the slower data transmission.

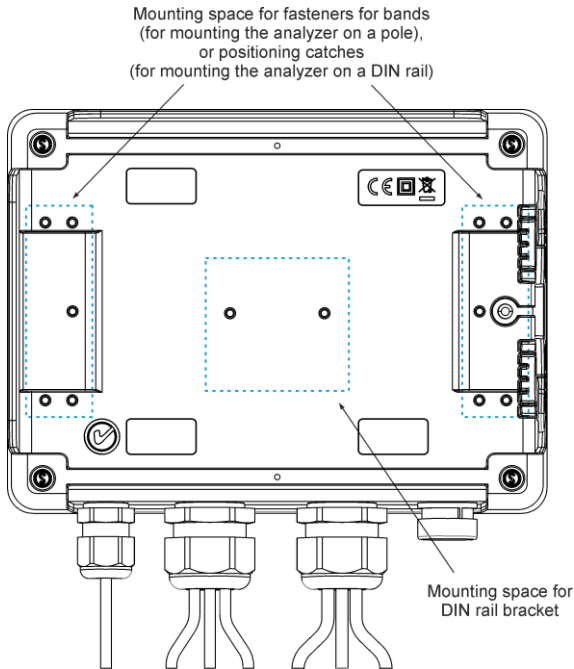

Fig. 2. The rear wall of the analyzer.

1 General information

GSM network transmission requires an active user's SIM card to be inserted into the slot of the analyzer. The card should have the service of data transmission activated and a static IP number. A PC connected to the analyzer, must have the Internet access.

PQM-703 **PQM-711** Compared to PQM-702 and PQM-710 models, PQM-703 and PQM-711 analyzers additionally enables the user to measure transient voltages in the range of ± 8 kV with sampling rate from 100 kHz to 10 MHz. Measuring circuits for transients are independent from the rest of voltage circuits and connected to voltage inputs L1/A, L2/B, L3/C, N, PE. The analyzers have four measurement channels: L1/A-PE, L2/B-PE, L3/C-PE and N-PE. Recording time waveforms is done with user-defined pretrigger time and detection threshold, while the number of recorded samples is up to 20000 per channel (2 ms for 10 MHz sampling).

1.3 Power supply of the analyzer

The analyzer has a built-in power adapter with nominal voltage range of 100...690 V AC or 140...690 V DC (90...760 V AC or 127...760 V DC including fluctuations). The power adapter has independent lines (red) marked with letter P (*power*). To prevent the power adapter from being damaged by undervoltage, it automatically switches off when powered with input voltages below approx. 80 V AC (110 V DC).

To maintain power supply to the device during power outages, the internal rechargeable battery is used. It is charged when the voltage is present at terminals of the AC adapter. The battery is able to maintain power supply up to 2 h hours (PQM-702, PQM-710) at temperatures of $-20...+55^{\circ}\text{C}$. After the battery is discharged the meter stops its current operations (e.g. recording) and switches off in the emergency mode. When the power supply from mains returns, the analyzer resumes interrupted recording.

Note

The battery may be replaced only by the manufacturer's service department.

1.4 Tightness and outdoor operation

The analyzer is designed to work in difficult weather conditions - it can be installed directly on electric poles. Two bands with buckles and two plastic fasteners are used for mounting the analyzer. The fasteners are screwed to the back wall of the housing, and bands should be passed through the resulting gaps.

The ingress protection class of the analyzer is IP65, and operating temperature ranges from -20°C to +55°C.



Note

In order to ensure the declared ingress protection class IP65, the following rules must be observed:

- *Tightly insert the stoppers in the slots of USB and SIM card,*
- *Unused probe terminals must be sealed with silicone stoppers,*
- *Tighten the plug of the socket used for external GPS antenna (or tightly screw the external GPS antenna into the socket).*

At ambient temperatures below 0°C or when the internal temperature drops below this point, the internal heater of the device is switched on - its task is to keep the internal temperature above zero, when ambient temperatures range from -20°C to 0°C.

The heater is powered from the AC/DC power adapter, and its power is limited to approx. 5 W.

Due to the characteristics of the built-in lithium-ion rechargeable battery, the process of charging is blocked when the battery temperature is outside the range of -10°C...60°C (in such case, *Sonel Analysis* software indicates charging status as "charging suspended").

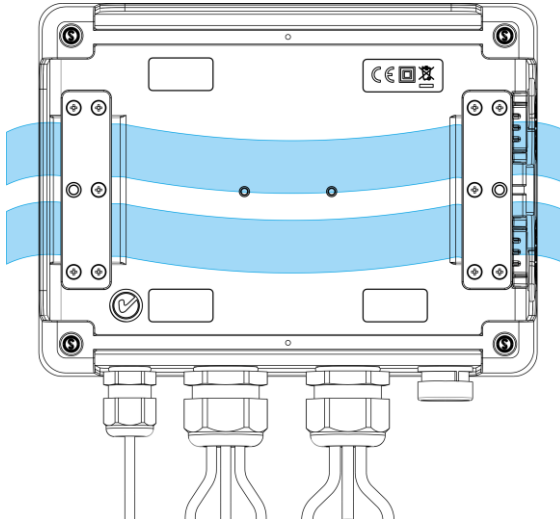
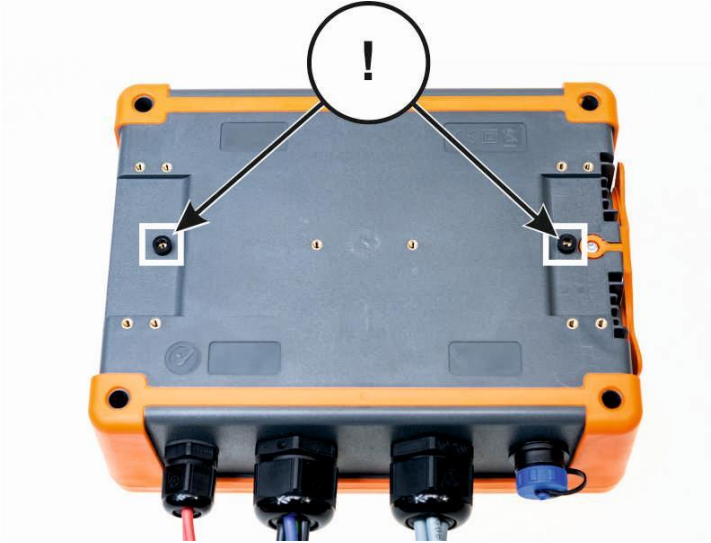

Fig. 3. Fasteners for bands (for mounting the analyzer on a pole)

1.5 **Mounting the fasteners**

1. Place the plastic spacer tubes 3 mm on the underside of the lower housing, in places marked on the photo.



2. Place the fasteners on the pole clamps on the underside of the lower housing, in places marked on the photo.

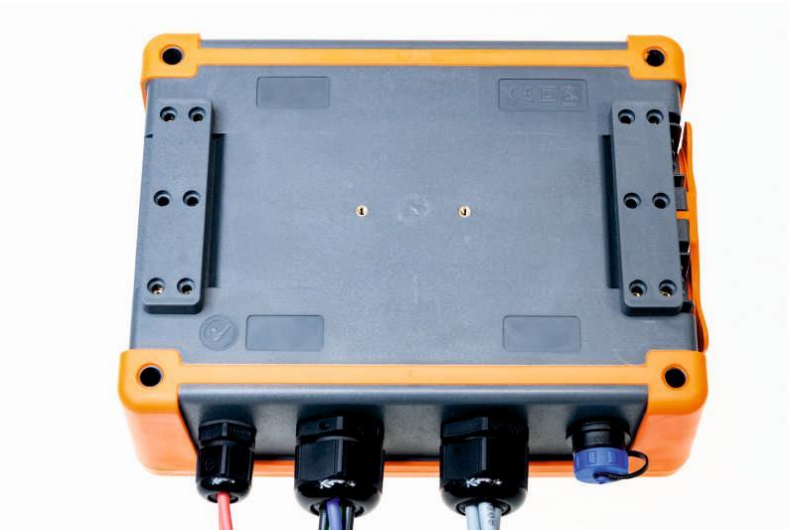

3. Tighten the fasteners to the housing using ten (10 pcs) M3x10 screws. **Use only the screws with dimensions specified in this manual.**

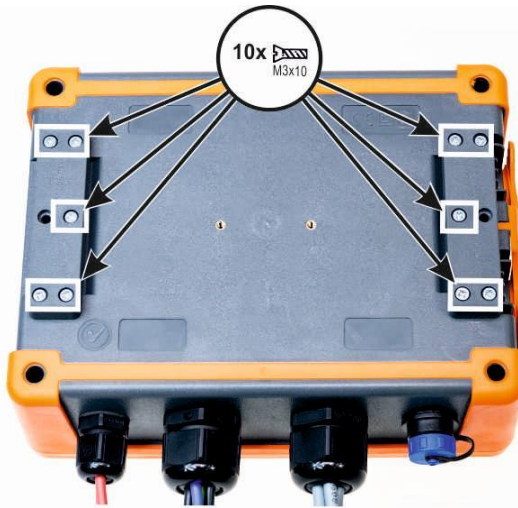

1.6 Mounting on DIN rail

The device is supplied with a bracket for mounting the analyzer on a standard DIN rail. The bracket must be fixed to the back of the analyzer with the provided screws. The set includes also positioning catches (in addition to fasteners for mounting the analyzer on a pole), which should be installed to increase the stability of the mounting assembly. These catches have special hooks that are supported on the DIN rail.

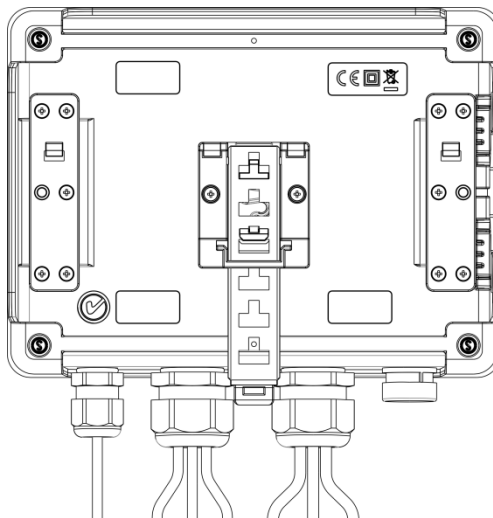

Fig. 4. The rear wall of the analyzer with fixtures for mounting on DIN rail.

1.7 Measured parameters

The analyzer is designed to measure and record the following parameters:

- RMS phase and phase-to-phase voltages - up to 760 V or 1000 V referred to ground depending on version (peak voltages up to ± 1500 V),
- **PQM-703** **PQM-711** transient voltages (overvoltages) in the range up to ± 8 kV,
- RMS currents:
 - up to 6000 A (peak currents up to ± 20 kA) using flexible probes,
 - up to 1400 A using hard clamps,
- Crest Factors for current and voltage,
- mains frequency within the range of 40..70 Hz,
- active, reactive and apparent power and energy, distortion power,
- harmonics of voltages and currents (up to 50th),
- Total Harmonic Distortion THD_F and THD_R for current and voltage,
- Total Demand Distortion for currents (TDD),
- K-Factor (loss factor in transformers caused by higher harmonics),
- active and reactive powers of harmonics,
- the angles between voltage and current harmonics,
- Power Factor, $\cos\phi$ (DPF), 4-quadrant tangent ϕ ,
- unbalance factors and symmetrical components for three-phase mains,
- flicker severity P_{ST} and P_{LT} ,
- interharmonics of voltages and currents (up to 50th),
- Total Interharmonic Distortion TID_F and TID_R for current and voltage,
- mains signaling voltage in the frequency band of 5...3000 Hz,
- Rapid Voltage Changes (RVC).

Some of the parameters are aggregated (averaged) according to the time selected by the user and may be stored on a memory card. In addition to average value, it is also possible to record minimum and maximum values during the averaging period, and to record the instantaneous value occurring at the end of aggregation period.

The module for event detection is also powerful. According to EN 50160, typical events include voltage dip (reduction of RMS voltage to less than 90% of nominal voltage), swell (exceeding 110% of the nominal value) and interruption (reduction of the supplied voltage below 5 % of the nominal voltage) The user does not have to enter the settings defined in EN 50160, as the software provides an automatic configuration of the device to obtain power quality measurement mode compliant with EN 50160 The user may also perform manual configuration - the software is fully flexible in this area. Voltage is only one of many parameters for which the limits of event detection may be defined. For example, the analyzer may be configured to detect power factor drop below a defined value, THD exceeding another threshold, and the 9th voltage harmonic exceeding a user-defined percentage value. Each event is recorded along with the time of occurrence. For events that relate to exceeding the pre-defined limits for voltage dip, swell, interruption, and exceeding minimum and maximum current values, the recorded information may also include a waveform for voltage and current. It is possible to record from 5 mains cycles of up to 1 second, with adjustable pre-triggering time. Together with the waveform, half-cycle RMS values ($RMS_{1/2}$) may be also recorded with time adjustable from 1 s to 30 s.

Additionally, the analyzer has the ability to detect events caused by the change of the shape of the voltage envelope and the voltage phase angle, by comparing consecutive successive periods of the network with each other.

A very wide range of configurations, including a multitude of measured parameters make the analyzer an extremely useful and powerful tool for measuring and analyzing all kinds of power supply systems and interferences occurring in them. Some of the unique features of this device make it distinguishable from other similar analyzers available in the market.

Tab. 2 presents a summary of parameters measured by analyzer, depending on the mains type.

Tab. 2. Measured parameters for different network configurations.

Parameter		Network type, channel		1-phase			split-phase			3-phase 4-wire					3-phase 3-wire			
		L1/A	N	L1/A	L2/B	N	Σ	L1/A	L2/B	L3/C	N	Σ	L12/AB	L23/BC	L31/CA	Σ		
U	RMS voltage	•	•	•	•	•		•	•	•	•		•	•	•			
U _{DC}	DC voltage	•	•	•	•	•		•	•	•	•		•	•	•			
I	RMS current	•	•	•	•	•		•	•	•	•		•	•	•			
I _{DC}	DC current	•	•	•	•	•		•	•	•	•		•	•	•			
F	Frequency	•		•				•					•					
CF U	Voltage crest factor	•	•	•	•	•		•	•	•	•		•	•	•			
CF I	Current crest factor	•	•	•	•	•		•	•	•	•		•	•	•			
P	Active power	•		•	•		•	•	•	•	•		•			•		
Q ₁ , Q _B	Reactive power	•		•	•		•	•	•	•	•					• ⁽¹⁾		
D, S _N	Distortion power	•		•	•		•	•	•	•	•							
S	Apparent power	•		•	•		•	•	•	•	•					•		
PF	Power Factor	•		•	•		•	•	•	•	•					•		
cosφ/DPF	Displacement power factor	•		•	•		•	•	•	•	•							
$\tan\phi_{C-}, \tan\phi_{L+}$ $\tan\phi_{L-}, \tan\phi_{C+}$	tangent φ factor (4-quadrant)	•		•	•		•	•	•	•	•					• ⁽¹⁾		
THD U	Voltage total harmonic distortion	•	•	•	•	•		•	•	•	•		•	•	•			
THD I	Current total harmonic distortion	•	•	•	•	•		•	•	•	•		•	•	•			
TDD I	Total Demand Distortion	•	•	•	•	•		•	•	•	•		•	•	•			
K	K-Factor	•	•	•	•	•		•	•	•	•		•	•	•			
E _{P+} , E _{P-}	Active energy (consumed and supplied)	•		•	•		•	•	•	•	•		•			•		
E _{QC-} , E _{OL+} E _{OL-} , E _{QC+}	Reactive energy (4-quadrant)	•		•	•		•	•	•	•	•		•			• ⁽¹⁾		
E _S	Apparent energy	•		•	•		•	•	•	•	•		•			•		
U _{h1..U_{h50}}	Voltage harmonic amplitudes	•	•	•	•	•		•	•	•	•		•	•	•			
I _{h1..I_{h50}}	Current harmonic amplitudes	•	•	•	•	•		•	•	•	•		•	•	•			
φ _{U11..φ_{U150}}	Angles between voltage and current harmonics	•		•	•			•	•	•	•							
P _{h1..P_{h50}}	harmonics active power	•		•	•			•	•	•	•							
Q _{h1..Q_{h50}}	harmonics reactive power	•		•	•			•	•	•	•							
Unbalance U, I	Symmetrical components and unbalance factors											•				•		
P _{st} , P _{It}	Flicker	•		•	•			•	•	•	•		•	•	•			
TID U	Voltage total interharmonic distortion	•	•	•	•	•		•	•	•	•		•	•	•			
TID I	Current total interharmonic distortion	•	•	•	•	•		•	•	•	•		•	•	•			
U _{ih0..U_{ih50}}	Voltage interharmonics amplitudes	•	•	•	•	•		•	•	•	•		•	•	•			
I _{ih0..I_{ih50}}	Current interharmonics amplitudes	•	•	•	•	•		•	•	•	•		•	•	•			
UR1, UR2	Mains signalling in voltage	•		•	•			•	•	•	•		•	•	•			
PQM-703 PQM-711 U _t	Voltage transients ⁽²⁾	•	•	•	•	•		•	•	•	•		•	•	•			

Explanations:





L1/A, L2/B, L3/C (L12/AB, L23/BC, L31/CA) indicate subsequent phases

N is a measurement for voltage channel N-PE or current channel I_N, depending on the parameter type, Σ is the total value for the system.







- (1) In 3-wire networks, the total reactive power is calculated as inactive power $N = \sqrt{S_0^2 - P^2}$ (see discussion on reactive power in Power Quality Guide document).
- (2) Voltage transients are measured in channels: L1/A-PE, L2/B-PE, L3/C-PE and N-PE.

2 Operation of the analyzer

2.1 Buttons

The keyboard of the analyzer consists of four buttons: ON/OFF , LEFT , RIGHT , START/STOP . To switch-on the analyzer, press ON/OFF button. Directional buttons LEFT and RIGHT are used primarily to change the information screens. The screens change circularly, i.e. after pressing RIGHT button, when the last screen is displayed, the device goes to screen 1. After pressing LEFT button, screens are displayed in reverse order. START/STOP button is used to start and stop the recording as defined in the configuration of current set point.

2.2 Switching the analyzer ON/OFF

- The analyzer may be switched-on by briefly pressing button . Then a welcome screen is displayed, showing the name of the meter, the internal software version (firmware), hardware version and serial number. Then, the analyzer performs a self-test and in case of detecting errors, the display shows an error message, accompanied by a long beep. When an error occurs during memory card launching, the following message is displayed **MEMORY CARD ERROR**. If the file system on the card is damaged (e.g. when the user manually formatted the card as mass storage memory accessible only for the user) the analyzer will suggest formatting the memory (message **FORMAT MEMORY CARD?**) and button  will trigger the process of formatting (3 short beeps). If the user does not press any button for 15 sec. the analyzer will restart. After the formatting is completed, the analyzer will repeat initialization of the card.
- When during the card initialization, the analyzer detects FIRMWARE.PQF file in the root directory, which includes a newer version of the firmware (internal software), the upgrade process will be suggested by the analyzer by displaying message **UPDATE FIRMWARE?**. Button  triggers this process (3 short beeps) and its progress may be observed on the display. The update may be skipped by briefly pressing the button . The update is also skipped if the user does not press any button for 10 sec. When the update is successfully completed, message **UPDATE SUCCESSFUL!**, will be displayed or in other case **UPDATE FAILED!**. Then the analyzer will automatically restart.
- After switching on, the analyzer is activated at the last measurement point and displays screen 1 with a phasor diagram.
- To switch the analyzer OFF, keep button  pressed for 2 seconds, when no button or recording lock are active.
- Pressing the active button results in a short beep of a higher pitch; for inactive button the beep is longer and at a lower pitch.
- Pressing button  or  for at least 1.5 s forces the display to refresh.

2.3 Auto-off

When the analyzer operates for at least 30 minutes powered by the battery (no power supply from mains) and it is not in the recording mode and PC connection is inactive, the device automatically turns-off to prevent onward discharging of the battery.

The analyzer turns off automatically also when the battery is fully discharged. Such emergency shut-down is performed regardless of the mode of the device. In case of active recording, it will be interrupted. When the power supply returns, the recording process is resumed. Emergency shut-down is signalled by message **BATTERY DISCHARGED!**

2.4 Screens

Note

Screens count is device dependent. PQM-702 and PQM-703 have 9 screens, whereas PQM-710 and PQM-711 have 10 screens.

Fig. 5 presents the first screen displayed by the analyzer. The bar in the upper part is a permanent element, shown independent of the selected screen.

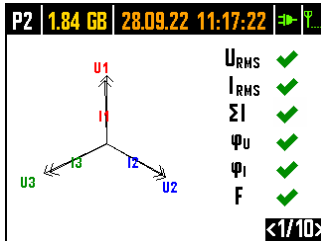





Fig. 5. Screen 1 with a phasor diagram and indicators of connection correctness.

The bar includes (from the left):

- number of active measurement point (configuration): **P1**, **P2**, **P3** or **P4**. In some modes measurement point number is displayed alternately with additional graphic symbol:
-  The symbol of sinusoid is displayed when the memory of the measurement point is completely filled with recorded data, or when the measurement point is not assigned to any place (zero allocation). In such conditions, recording cannot be started; only viewing the current values is possible.
-  The symbol of slope with an arrow indicates waiting for triggering the recording process by the first detected event (threshold triggering).
-  The hourglass symbol indicates waiting for recording to start in the scheduled recording mode (also between recording intervals).
- available space on the memory card for an active measurement point - in MB or GB.
- current date and time in the format day.month.year, hour:minute:second. Date and time are displayed in green, when time of the analyzer is synchronized to GPS time and meets the requirements for the accuracy specified in IEC 61000-4-30 and valid for analyzers of class A. If time does not meet these requirements, it is displayed in orange.
- indicator of mains power supply or battery status,
- indicator of GSM network signal strength (if a SIM card is inserted and connection GSM network is active).

Screen number is displayed in the lower right corner of the display.

Screen 1 is displayed by default after turning the analyzer on and after changing a measurement point. It presents a phasor diagram of the measured mains and indicators of correct connection to the mains. This feature is described in section 2.5.

2 Operation of the analyzer

Screen 2 is shown in Fig. 6. It shows the measured values of RMS voltages and currents within the tested system and the mains frequency. The frequency value is displayed in orange when there is no PLL synchronization or when the analyzer is working on the internal generator (e.g. in the absence of voltage U_{L1}).

PQM-702T Additionally, for PQM-702T, after connecting ST-2 temperature probe to the analyzer, the sensor temperature is displayed on the screen on a current basis.

P3	1.80 GB	20.12.12	11:30:10	⇒	%
U1	= 224.57 V	I1	= 22.27 A		
U2	= 227.86 V	I2	= 28.39 A		
U3	= 228.03 V	I3	= 23.37 A		
Unpe	= 0.0218 V	In	= 10.95 A		
f	= 50.000 Hz				
					<2/9>

Fig. 6. Screen 2 with the values of effective voltages and currents.

Screen 3 (Fig. 7) shows the active and passive power values. Power values of successive phases are marked with numbers from 1 to 3. Total power values are displayed in the last line (marked as P and Q).

P3	1.80 GB	20.12.12	11:30:09	⇒	%
P1	= 4.825 kW	Q1	= 929.3 var		
P2	= 6.301 kW	Q2	= 1.087 kvar		
P3	= 4.981 kW	Q3	= 1.289 kvar		
P	= 16.11 kW	Q	= 3.307 kvar		
					<3/9>

Fig. 7. Screen 3 with active and reactive power.

Screen 4 (Fig. 8) shows values of apparent distortion power (marked as SN) and values of apparent power (S). When the user selected power measurement according to Budeanu method instead of apparent power distortion, the device displays distortion power "D".

P3	1.80 GB	20.12.12	11:30:08	⇒	%
SN1	= 984.6 var	S1	= 7.617 kVA		
SN2	= 778.3 var	S2	= 10.04 kVA		
SN3	= 1.100 kvar	S3	= 8.081 kVA		
SN	= 4.831 kvar	S	= 26.28 kVA		
					<4/9>

Fig. 8. Screen 4 with apparent and deformation power values.

Screen 5 (Fig. 9) indicates THD factors in voltage and current. The factors shown on this screen are related to the fundamental component.

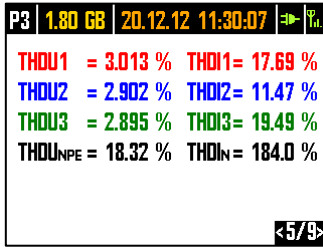

Fig. 9. Screen 5 with THD factors.

On screen 6 (Fig. 10) Power Factors (PF) are presented along with $\tan\phi$ (i.e. the ratio of reactive power to active power).

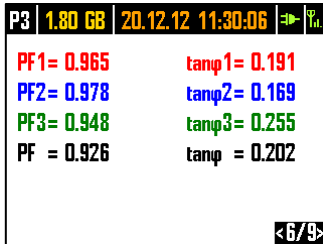

Fig. 10. Screen 6 with power factors and $\tan\phi$.

Screen 7 is the last of the measurement screens and it presents short-and long-term flicker factors P_{st} and P_{lt} . P_{st} flicker severity is updated every 10 minutes, whereas P_{lt} flicker severity every two hours.

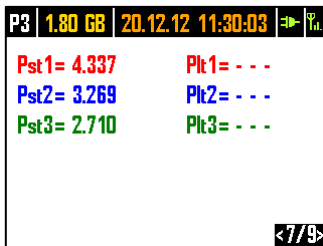

Fig. 11. Screen 7 with flicker.

2 Operation of the analyzer

Screen 8 presents the following information:

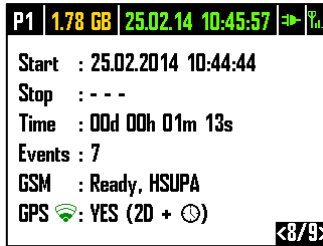

Fig. 12. Screen 8.

- start-time of the last recording, or the start-time of the next scheduled recording interval in the scheduled recording mode,
- end-time of the last recording (when recording is in progress dashes are displayed), or the end-time of the next scheduled recording interval in the scheduled recording mode,
- duration of the current or completed recording, optionally - duration of the interval in the scheduled recording mode,
- the number of events recorded by the analyzer from the start of recording,
- GSM network status. This line displays messages that relate to the current status of the built-in GSM modem:
 - **TURNING ON...:** the modem is being activated,
 - **CONNECTING TO NETWORK:** the modem logs on to GSM network
 - **CONNECTING TO INTERNET:** the modem initiates exchanging data packets and connects with the Internet,
 - **READY, LTE:** the modem has properly registered itself in GSM network and waits for a client connection. LTE is the name of a standard for data exchange, which depends on the availability of services in a given area.

The analyzer may display different messages here, e.g. indicate errors: **NO SIM CARD** when the SIM card is not inserted, **INVALID PIN** when PIN submitted by the analyzer was rejected by the SIM card, etc. More related information may be found in the chapter on GSM connections - section 2.13.

- the last line of screen 8 shows the status of the GPS receiver: when sufficient signal is received from GPS satellites (from internal or external antenna), the device displays word **YES**. When no signal is received, the device displays **NO SIGNAL** message. See more about GPS receiver in section 2.12.
- current level of GPS signal,
- information about GPS position (**2D**) and/or about receiving the correct GPS time (clock icon).

Screen 9 (Fig. 13) allows user to quickly view the main configuration parameters of the measurement point:

- mains system,
- probes type; in case of configurations with automatic probes recognition, the **AUTO** is displayed and in brackets the recognized probes model or **?** symbol if the probes are not connected or their configuration is invalid (i.e. not all required probes were connected or connected probes are of different types).
- nominal values of: voltage, current and frequency.

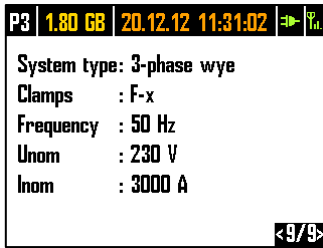



Fig. 13. Screen 9 with information on the measurement point settings.

PQM-710 **PQM-711** Screen **10** displays the current status of the wireless Wi-Fi connection. Using this screen, you can read:

- radio signal level (in client mode) – indicated by icon , where the number of green fields represents the signal level from 0 – none, to 4 – high (in Access Point mode, this place displays **AP**),
- connection status (**READY**, **GETTING IP ADDRESS**, **SEARCHING FOR NETWORK**)
- MAC address of the analyzer Wi-Fi interface,
- IP address of the analyzer in the Wi-Fi network. If the address is automatically assigned, then message (**DHCP**) is displayed,
- SSID of the Wi-Fi network, to which the analyzer is connected (in client mode) or in network distributed by the analyzer (in Access Point mode).

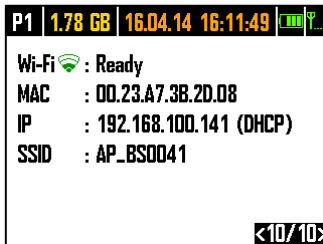

















Fig. 14. Screen 10 with information on the current status of Wi-Fi connection (PQM-710 and PQM-711 only).



2.5 Verifying the connection

Screen 1, next to phasor diagram displays correct connection indicators (see. Fig. 5), which give some relevant information on connecting the analyzer the tested network. This information helps the user to verify the compliance of the current configuration of the analyzer with the parameters of the measured network.

The indicators are sequentially marked as: U_{RMS} , I_{RMS} , φ_U , φ_I , f .

- **U_{RMS}** : effective values of voltages – two possible icons:
 -  - RMS voltages are correct, they are within the tolerance range of $\pm 15\%$ of the nominal voltage,
 -  - RMS values are outside the range of $U_{NOM} \pm 15\%$.
- **I_{RMS}** : effective values of current values – four options:
 -  - RMS currents are in the range of $0.3\% I_{NOM} \dots 115\% I_{NOM}$,
 -  - RMS currents are lower than $0.3\% I_{NOM}$,
 -  - RMS currents are higher than $115\% I_{NOM}$,
 - --- dashes are displayed when the current measurement is disabled in the configuration.

In all systems where it is possible the analyzer also calculates the sum of all the currents (instantaneous values) and checks if it totals to zero. This helps in determining if all current probes are connected correctly (i.e. arrows on current probes facing to the load). If the calculated current sum RMS value is higher than 0.3% of I_{nom} , it is treated as an error and the  icon is displayed.
- **ΣI** : The analyzer verifies the correctness of the clamps' connection on the basis of the instantaneous sum of all currents. In a closed system, the RMS value of the instantaneous sum of the current should be close to zero. The verification is only performed when the RMS of at least one measured current exceeds 0.3% of I_{nom} . In measuring systems with analytical calculation of the I_n current and in Aron circuits, this checking is disabled.
 -  - clamps connected correctly - the instantaneous sum of currents is close to zero,
 -  - the correctness of summing the currents cannot be verified due to too low current values,
 -  - the calculated RMS value of the instantaneous sum of the currents exceeds 0.3% of I_{nom} and at the same time it exceeds 25% of the maximum value of all measured currents. Such a situation may occur, e.g. when the clamps are connected inversely on the N conductor.
- **φ_U** : vectors - the analyzer verifies the correctness of the fundamental component angles and displays the corresponding icon:
 -  - the vectors have correct angles in the range of $\pm 30^\circ$ of the theoretical value for a resistive load and symmetrical circuit (in 3-phase systems),
 -  - the accuracy of angles cannot be verified, because the RMS voltage value is too low (less than 1% of U_{NOM}),
 -  - incorrect angles of vectors. In three-phase systems, this icon is displayed, among others, in case of reversed sequence of voltage phases.
- **φ_I** : current vectors - correctness of current vector angles is verified in relation to the voltage vectors. The following icons are displayed:
 -  - vectors are within $\pm 55^\circ$ in relation to angles corresponding to the voltage vectors,
 -  - the accuracy of current vector angles cannot be verified, because the RMS current values are too low (below 0.3% of I_{NOM}),
 -  - vectors are outside the acceptable range of angles ($\pm 55^\circ$),
 - --- dashes are displayed when the current measurement is disabled in the configuration.

- **f**: frequency:
 -  – the measured grid frequency is in the range of $f_{NOM} \pm 10\%$,
 -  - the RMS value of reference voltage phase is lower than 10V (the analyzer operates with internal generator) or there is no PLL synchronization,
 -  - the measured frequency is outside of $f_{NOM} \pm 10\%$.

Example from Fig. 5 illustrates the situation of incorrect connection of current clamps (swapped channels I_2 and I_3) – the icon ϕ_1 indicates an error in current vectors.

2.6 "Sonel Analysis" software





"Sonel Analysis" is an application required to work power analyzers of PQM series. It enables the user to:

- configure the analyzer,
- read data from the device,
- real-time preview of the mains,
- delete data in the analyzer,
- present data in the tabular form,
- present data in the form of graphs,
- analyzing data for compliance with EN 50160 standard (reports), system commands and other user-defined reference conditions,
- independent operation of multiple devices,
- upgrade the software and the device firmware to newer versions.

Detailed manual for "Sonel Analysis" is available in a separate document (also downloadable from the manufacturer's website www.sonel.com).

2.7 PC connection and data transmission

The analyzer provides three ways of communication with a PC. They are as follows:

- wired communication via USB,
-   radio communication in 433 MHz band using OR-1 receiver,
- built-in wireless connectivity via GSM modem,
-   radio communication via wireless Wi-Fi transmission – a PC and the analyzer must be connected to the same LAN (or directly with each other, if the analyzer operates in Access Point mode) or have the ability to communicate through the WAN (correct configuration of the router).





Connection to a computer (PC mode), ensures:

- Transmission of data stored in the recorder memory:
 - it is possible to read the data of all measurement points regardless of the recording state,
- Viewing mains parameters on PC:
 - instantaneous values of: current, voltage, power and energy, total values for the entire system,
 - harmonics, interharmonics, harmonic power values, THD, TID,
 - unbalance,
 - phasor diagrams for voltages,
 - current and voltage waveforms drawn in real-time,
 - all other measured parameters not listed here.
- Analyzer configuration, remote triggering and stopping of the recording process.
- When connected to a PC, the display shows message **PC CONNECTION** and the type of connection.

2 Operation of the analyzer

- When connected to a PC, all analyzer buttons are locked except  button, but when the analyzer operates with key lock mode (e.g. during recording), all the buttons are locked.
- To connect to the analyzer, enter its PIN code. The default code is 000 (three zeroes). The PIN code may be changed using "Sonel Analysis" software.
- When wrong PIN is entered three times in a row, data transmission is blocked for 10 minutes. Only after this time, it will be possible to re-entry PIN.
- When within 30 seconds of connecting a PC to the device no data exchange occurs between the analyzer and the computer, the analyzer exits data exchange mode and terminates the connection.

Notes

- Holding down buttons  and  for 5 seconds results in an emergency setting of PIN code (000).
- If the keys are locked during the recording process, this lock has a higher priority (first the user would have to unlock buttons to reset the emergency PIN). To unlock the keypad in emergency cases hold buttons  and  pressed for 5 seconds.

- If there is an active connection via one of the media, it is not possible to communicate with the analyzer using another medium type, e.g. a USB connection is active, the user cannot use OR-1 radio or GSM connection. In this case, the device displays a message that another connection is already active.

2.7.1 USB communication

USB is an interface that is continuously active and there is no way to disable it. To connect the analyzer, connect USB cable to your PC (USB slot in the device is located on the left side and is secured with a sealing cap). Before connecting the device, install "Sonel Analysis" software with the drivers on the computer

Transmission speed is 921.6 kbit/s. In addition, a built-in mass-storage reader enables downloading recorded data with speed significantly higher than the standard speed. In this mode, the analyzer provides its memory card as a mass storage space, allowing you to read data at a speed of a few MB/s. During data read-out, the normal communication with the device is not available e.g. data preview in LIVE mode. After reading data from the memory card, "Sonel Analysis" automatically switches the analyzer from reader mode to standard communication mode.

Note

In the reader mode, the entire memory card appears as a drive in the operating system - this solution provides an unrestricted access to its contents. To prevent damaging the file system on the card and losing the stored data, the user must not interfere with the file system on the card (e.g. by creating and storing own files, or deleting files stored by the analyzer). For this purpose do not use programs other than Sonel Analysis.

Note

Use certified and good quality USB 2.0 cables with a length of no more than 5 meters. This is especially important in mass storage mode. It is recommended to use the USB cable supplied with the analyzer.

2.7.2 Radio communication via OR-1 **PQM-702** **PQM-702T** **PQM-703**

After connecting OR-1 radio module to a PC, the user may communicate with the analyzer using 433 MHz band. The range in this mode is limited to about 5 m, and the maximum rate data of data transmission is 57.6 kbit/s

Note

Before connecting to the analyzer through a wireless connection (OR-1 or GSM), the user must add the analyzer to the database of analyzers (**OPTIONS → ANALYZER DATABASE** in "Sonel Analysis"). When searching for analyzers, the list of displayed analyzers includes only those entered in the database. For more information - see the manual for "Sonel Analysis".

OR-1 is not supported by the devices (including their variants) with **serial numbers having the following prefixes:**

- PQM-702: LJ,
- PQM-703: LJ.

The radio interface that communicates with OR-1 receiver may be turned off in the analyzer. To switch it back on, use one of two remaining transmission modes: USB, or GSM.

2.7.3 Communication via GSM network

The built-in GSM modem ensures the access to the analyzer from any chosen global location with available GSM network. To operate this feature - insert a valid SIM card to the side slot of the analyzer.

The SIM card must have the following services activated:

- General Packet Radio Service,
- static IP address,
- SMS option to send alarm messages.

In order to configure the SIM card and modem in the analyzer, the user must obtain the following data from the data transmission service provider:

- PIN code for SIM card
- PUK code for SIM Card - for emergency cases, when SIM card is locked after repeated attempts of enter wrong PIN,
- IP number assigned to SIM card (it must be a static number),
- APN (*Access Point Name*),
- user name and password (optional, usually not required).

After inserting the SIM card for the first time into the analyzer, the device will attempt to use the PIN entered last time or the default code. Usually, such an attempt fails, and the analyzer displays the message about incorrect PIN code. To enter the correct data, establish a connection with the analyzer via USB (or OR-1) and configure a GSM connection. The procedure described in section

2 Operation of the analyzer

2.13.2. If the analyzer is configured correctly it will attempt to connect to the GSM network and then to the Internet. The analyzer will now be visible on the Internet with assigned IP number. The device will wait for incoming connections using port 4001. Such connection may be established by "Sone/Analysis"

If the GSM modem will not be used, it may be turned off using the program.

More information about the analyzer configuration for GSM communication is presented in section 2.13.

2.7.4 Radio communication via Wi-Fi **PQM-710 PQM-711**

PQM-710/711 analyzers are equipped with Wi-Fi module working in IEEE 802.11 b/g standard and n single stream. This allows the analyzer to communicate with the tablet (or computer) remotely. A direct connection: tablet ↔ analyzer is possible, as well as operation in a local network or via the Internet.

You can work in an open network or in a network secured with WPA/WPA2-PSK.

Warning

*In analyzers with firmware version 1.25 or older, the Wi-Fi module can work only in client mode.
Analyzers with version from 1.30 may work in two modes: client and access point (AP).*

Client mode

In client mode an external Access Point is used to establish a connection between the analyzer and PC. When connected to an Access Point, the analyzer starts TCP/IP server connections with static IP address or with an address assigned by DHCP server of the Access Point. TCP port used in the local network and for direct connections is 4002.

Connecting to the analyzer via the Internet requires a Wi-Fi router properly configured by the network administrator.

The analyzer, which has no Access Point within its range, remains in scanning mode of 2.4 GHz Wi-Fi band.

Access Point (AP) mode



In this mode, the analyzer is an Access Point, distributing the local network (SSID) with a name and password provided by the user. This Access Point may be used to connect with other devices such as PCs, tablets or mobile phones. By the default, the Access Point operates on channel No. 10. If necessary, the channel may be changed to another.

For more information about configuring Wi-Fi connection and the ways of connecting with the meter, refer to section 2.14.

2.8 Taking measurements

2.8.1 Measurement Points

The analyzer allows the user to store four completely independent measurement configurations, which are also called "measurement points." Number of active measurement point is shown in the upper left corner of the screen as an **P** with a digit **1...4**.

Press buttons  and  at the same time and hold them pressed for 1 second to display the screen for selecting the measurement point Fig. 15.

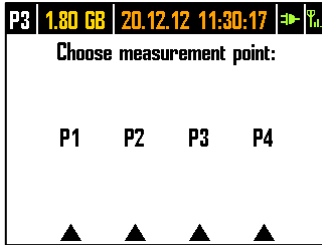





Fig. 15. Selection of the measurement point.

To select one of the four points, press the corresponding button indicated by a triangle on the screen:

- to select measurement point 1, select 
- to select measurement point 2, select 
- to select measurement point 3, select 
- to select measurement point 4, select 

After selecting the measurement point the analyzer displays the phasor diagram (screen 1), and checks the validity of mains connections. If an error is detected, the device emits a long beep.

If the user chooses to not to select the measurement point and does not press any key, after a few seconds, the analyzer returns to the previous screen.

In some cases, changing the measurement point is not possible. At least two of such cases are as follows:

- the analyzer is recording; in such case the device displays message **RECORDING IN PROGRESS**
- the communication with a PC is in progress (via USB, OR-1, Wi-Fi or GSM). In this case, LEFT and RIGHT keys are inactive.

The user may assign any chosen percentage of memory to each point (e.g. 100% for the first point and 0% for others or 25% for each point). If any measurement point has the whole memory assigned, selecting any other measurement point results in displaying the number of selected point alternately with the symbol of the sine wave, indicating that the parameters may be viewed only in "LIVE" mode.

2.8.2 Start / stop of recording



When the selected measurement point still has the assigned disk space left, the user may start recording by pressing button , or initiate it from the software using connected PC.

Starting the recording mode depends on how its configuration during the configuration of the measurement point. There are three modes available:

- Immediate start - when recording begins immediately after pressing the button.
- start after detecting the first event - in such case the analyzer waits for the record-triggering event. i.e. when the first of the parameters configured for the measurement point exceeds the threshold triggering the event. While waiting for the event, the analyzer uses the status bar to display the number of the measurement point alternately with the symbol of slope with an arrow.
- start according to scheduled recording time. Screen 8 may be used to see the next scheduled start and end of the recording process. At the same time the status bar displays the number of measurement point alternately with the hourglass symbol. If all the scheduled times are over, the recording process will be inactive (unavailable) and the status bar will display the number of measurement point, alternately with the sinusoid symbol (meaning that only Live preview of current mains values is possible).

The measurement point number, which is displayed in the upper left corner of the screen, flashes once per second, while the device is in the recording mode,

Stopping the recording process:

- Recording may be manually stopped by holding for one second button  or from the PC application.
- Recording ends automatically as scheduled (if the end time is set), in other cases the user stops the recording (using button  or the software).
- Recording ends automatically when all memory assigned to a measurement point on the memory card is filled. In this situation, the display will show the number of the measurement point alternately with the sinusoid symbol.
- The display will remain blank after the recording process is completed, if the user activated the "sleep mode". Press any button to turn the screen on and to display the last screen (if the key lock is off) or the screen requesting the code for unlocking the keypad (if the key lock is on).

2.8.3 Recording configuration

Before you start recording, it is necessary to configure the selected measurement point, to perform the recording process according to your requirements. The configuration is carried out using *Sonel Analysis* software. The analyzer is supplied from the factory with sample configurations, which are described in details in the manual for *Sonel Analysis*.

In general, there are three different types of recording:

- recording acc. to user configuration,
- recording for compliance with the standard (EN 50160 or other),
- dual recording, allowing user to perform parallel measurement according to user configuration and regardless of compliance with the standard.

Recording by user configuration provides flexibility in selecting parameters to be recorded. The user indicates the type of network, nominal parameters, averaging time and parameters to be recorded or activates event detection, etc.

Recording for compliance with the indicated standard may be followed by a compliance report, which is used to assess the quality of power supply in the tested network point. In earlier versions of analyzer firmware (v1.16 or older) in this mode, the user could specify additional recording parameters (except those required by the selected standard and automatically included), but the averaging time of all parameters could be only 10 minutes (as the main averaging time of the

standards). Firmware v1.17 offers a new method of recording, removes the restriction on the averaging time. This means that the user may activate recording for compliance with the standard and simultaneously record other parameters with different averaging time - i.e. as in recording for the user. This opens up completely new diagnostic possibilities. In the dual mode, the recording for standard compliance is performed in the background, completely independently.

One exception (restriction) in relation to recording acc. to the user configuration is blocking the possibility of changing detection thresholds for voltage event (dip, swell, interruption), due to the strict requirements for such events included in the standards. These events are also always active and cannot be disabled.

The second exception occurs when a Standard is chosen that requires recording of RVC events. In this case the RVC parameters are configured in selected Standard profile and cannot be changed in user configuration.

In cases when the user only wants recording for compliance with the Standard and does not want the analyzer to record additionally any other parameters (and thus increase unnecessarily the size of recorded data), turn off (by unchecking in settings) all other parameters, or choose a long averaging time from the list (even if the parameters are to be recorded, it will take relatively little space). However, this does not include events, so the best solution is to disable unnecessary parameters.

2.8.4 Approximate recording times

The maximum recording time depends on many factors such as the size of the allocated space on a memory card, averaging time, the type of system, number of recorded parameters, waveforms recording, event detection, and event thresholds. A few selected configurations are given in Tab. 3. The last column gives the approximate recording times when 2 GB of memory card space is allocated to a measurement point. The typical configurations shown below are based on the measurement of the N-PE voltage and I_N current.

Tab. 3. Approximate recording times for a few typical configurations.

Configuration type/ recorded parameters	Averaging time	System type (current measurement on)	Events	Event waveforms	Waveforms after averaging period	Approximate recording time with 2 GB allocated space
according to EN 50160	10 min	3-phase wye	• (1000 events)	• (1000 events)		> 10 years
according to the "Voltages and currents" profile	1 s	3-phase wye				270 days
according to the "Voltages and currents" profile	1 s	3-phase wye			•	4 days
according to the "Power and harmonics" profile	1 s	3-phase wye				23 days
according to the "Power and harmonics" profile	1 s	3-phase wye	• (1000 events)	• (1000 events)		22.5 days
all possible parameters	10 min	3-phase wye				4 years
all possible parameters	10 s	3-phase wye				25 days
all possible parameters	10 s	1-phase				64 days
all possible parameters	10 s	1-phase	• (1000 events / day)	• (1000 events / day)	•	14.5 days

2.9 Measuring circuits

The analyzer may be connected directly to the following types of networks:

- 1-phase (Fig. 16)
- 2-phase (split-phase) with split-winding of the transformer (Fig. 17),
- 3-phase 4-wire wye with a neutral conductor (Fig. 18),
- 3-phase 3-wire wye without neutral conductor (Fig. 19 ,Fig. 22),
- 3-phase 3-wire delta (Fig. 20 ,Fig. 21).

Indirect measurements in medium voltage networks can be performed:

- in wye network (Fig. 23),
- in delta network (Fig. 24).

Measurements in DC systems is possible in two configurations:

- DC – one-voltage DC system (Fig. 25)
 - DC+M – two-voltage DC system with middle point (Fig. 26)
- In DC systems, it is possible to measure the current using probes C-5A.

In three-wire systems, current may be measured by the Aron method, which uses only two probes that measure linear currents I_{L1} and I_{L3} . I_{L2} current is then calculated using the following formula:

$$I_{L2} = -I_{L1} - I_{L3}$$

This method can be used in delta systems (Fig. 21, Fig. 24) and wye systems without a neutral conductor (Fig. 22).

Note

As the voltage measuring channels in the analyzer are referenced to N input, then in systems where the neutral is not present, it is necessary to connect N input to L3 network terminal. In such systems, it is not required to connect L3 input of the analyzer to the tested network. It is shown in Fig. 19, Fig. 20, Fig. 21 and Fig. 22 (three-wire systems of wye and delta type).

For transient measurement in L3 channel the connection of L3 input is required.

In systems with neutral conductor, the user may additionally activate current measurement in this conductor, after installing additional probes in I_N channel. This measurement is performed after activating in settings the option of **N-CONDUCTOR CURRENT** with option **MEASURED**.

An alternative to I_N current measurement with probes is the calculation of current in neutral conductor applying the analytical method. The analyzer provides such option after selecting **N-CONDUCTOR CURRENT** and **CALCULATED**. Neutral current is calculated from the following relations:

- $I_N = -I_{L1}$, in a single-phase system,
- $I_N = -I_{L1} - I_{L2}$, in a 2-phase system,
- $I_N = -I_{L1} - I_{L2} - I_{L3}$, in a 3-phase 4-wire wye system.

These relations stated above are true provided that zero current is present in PE conductor. In typical situations, this current is indeed negligible, but note that in emergency situations (e.g. short circuit - until the switch breaker is tripped) current in PE conductor may reach significant values; therefore the calculated value of current I_N will differ from the actual.

Note

*In order to correctly calculate total apparent power S_e and total Power Factor (PF) in a 4-wire 3-phase system, it is necessary to measure the current in the neutral conductor. Then it is necessary to activate option **N-conductor current** and connect 4 probes, as shown in Fig. 18. Another option is to turn on analytical calculation of current I_N . More information on total apparent power S_e - see Power Quality Guide.*



For systems with available PE and N conductors (earthing and neutral) it is also possible to measure N-PE voltage. To do this, connect PE conductor to PE voltage input of the analyzer. In addition, select option **N-PE VOLTAGE** in measurement point settings.

Pay attention to the direction of current probes (flexible and CT). The probes should be installed with the indicating the load direction. It may be verified by conducting an active power measurement – in most types of passive receivers active power is positive. When probes are incorrectly connected, it is possible to change their polarity using "SoneI Analysis" software.

PQM-703 PQM-711 When measuring overvoltages (transients) is also required, remember that the analyzer measures them in relation to PE input. Therefore, in such cases always ensure that PE input of the analyzer is connected to a local earthing. This remark applies to all types of systems, including 3-wire systems. Unconnected PE conductor will result in a failure to detect transients. In 3-phase 3-wire systems, to be able to detect transients in L3 voltage channel, a L3 input must be connected to the tested mains (in these systems, when transients measurement is not needed, L3 input can be left disconnected).

The following figures show schematically how to connect the analyzer to the tested network depending on its type.

Icons used in the drawings with respect for optional connections have the following meanings:

-  if U_{N-PE} voltage measurement is required, make connection as shown by the icon in diagram (connect PE input to the protective conductor)
-  if I_N current measurement is required, make connection as shown by the icon in diagram (connect probes in channel I_N).
-  if transients measurement is required, make connection as shown by the icon in diagram (connect PE input to the local earthing or protective conductor, and L3 input depending on mains system).

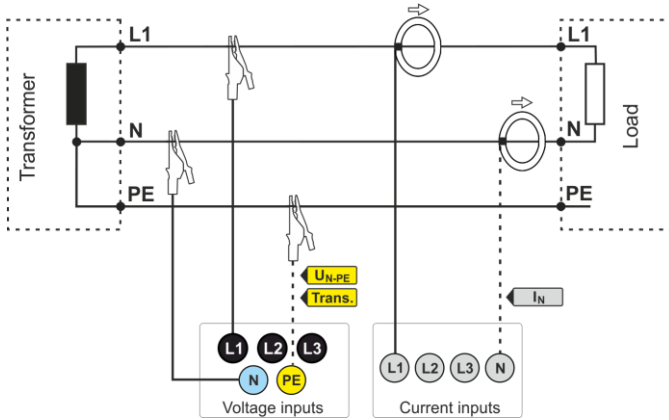

Fig. 16. Wiring diagram – single phase.

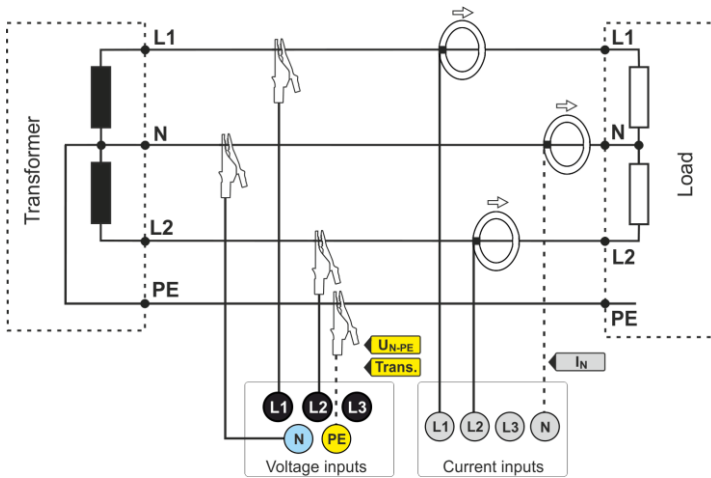

Fig. 17. Wiring diagram – split-phase.

2 Operation of the analyzer

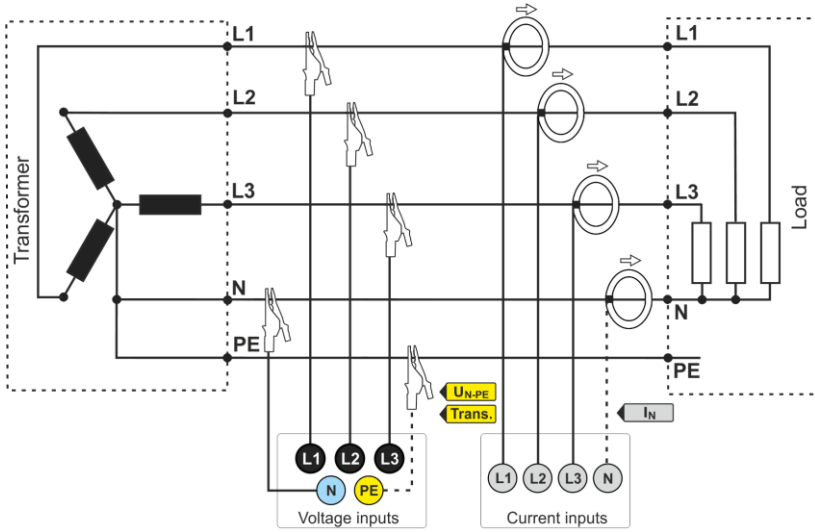

Fig. 18. Wiring diagram – 3-phase wye with a neutral conductor.

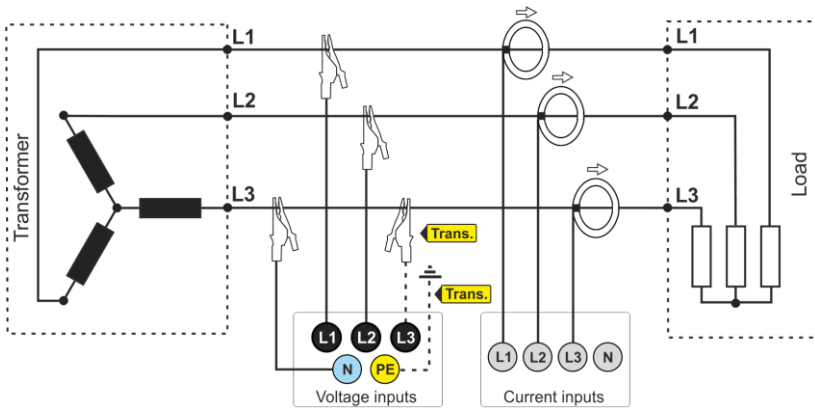

Fig. 19. Wiring diagram – 3-phase wye without neutral conductor.

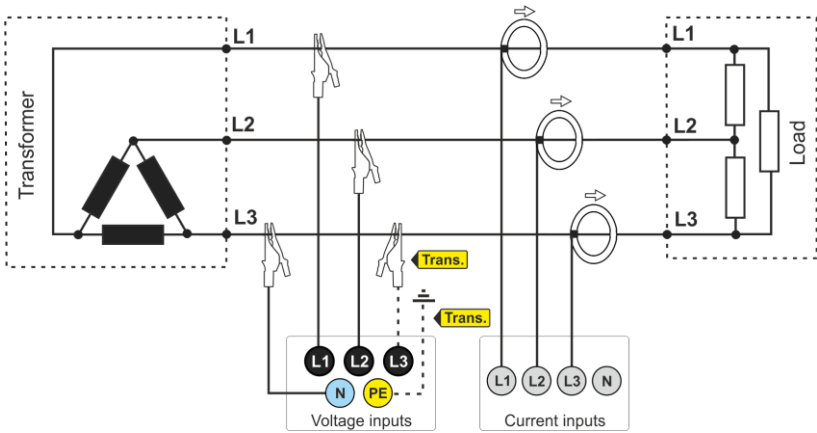

Fig. 20. Wiring diagram – 3-phase delta.

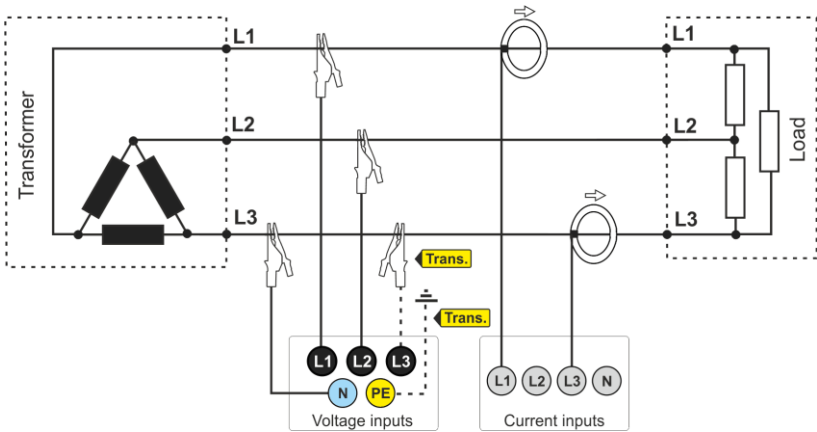

Fig. 21. Wiring diagram – 3-phase delta (current measurement using Aron method).

2 Operation of the analyzer

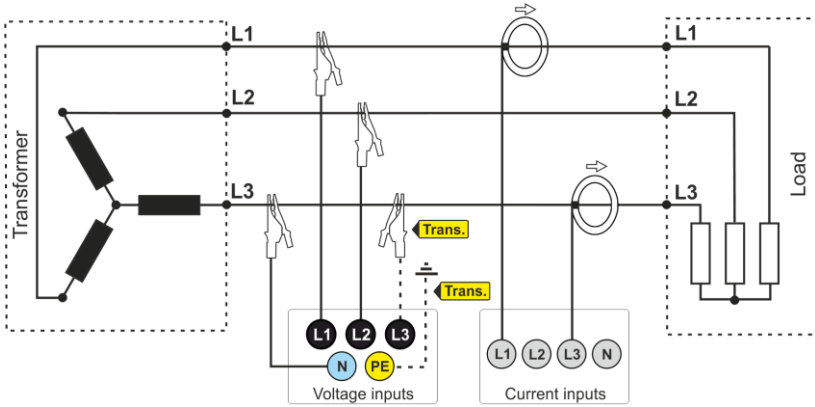

Fig. 22. Wiring diagram – 3-phase wye without neutral conductor (current measurement using Aron method).

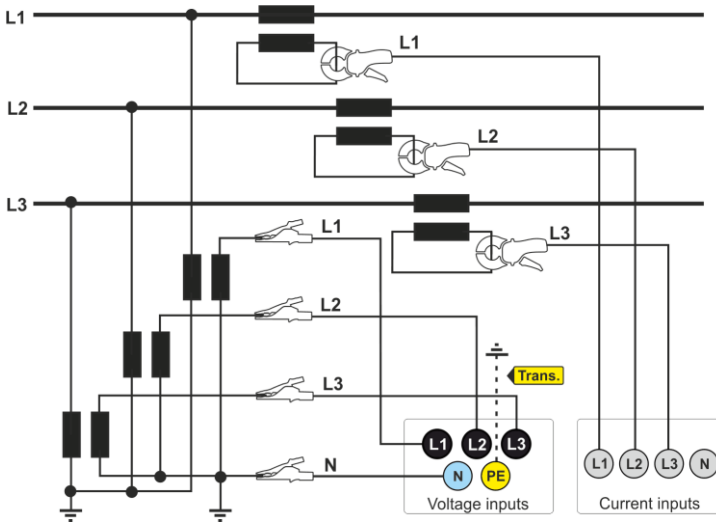

Fig. 23. Wiring diagram – indirect system with transducers – wye configuration.

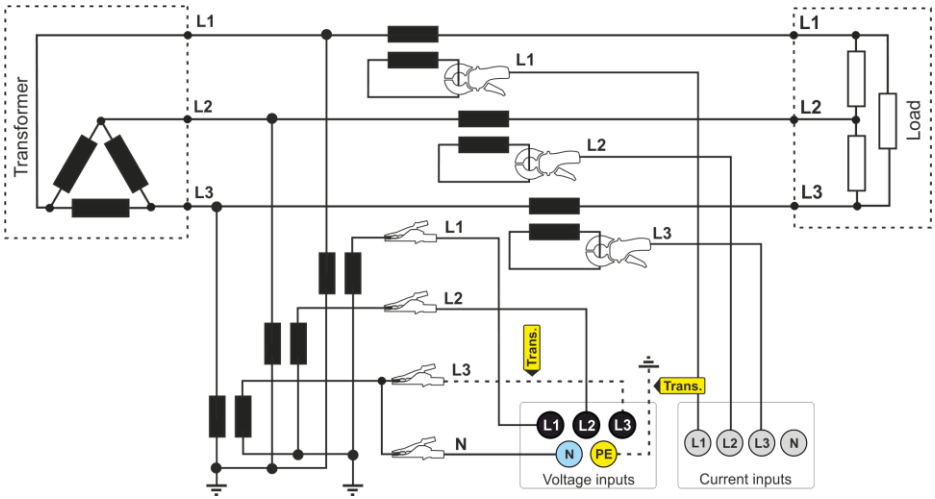

Fig. 24. Wiring diagram – indirect system with transducers – delta configuration.

Note

Frequency response of transformers is usually very narrow, so the network disturbances at high frequencies (e.g. lightning surges) are largely suppressed and distorted on the secondary side of the transformer. This should be taken into account when making transient measurements in configuration with transformers.

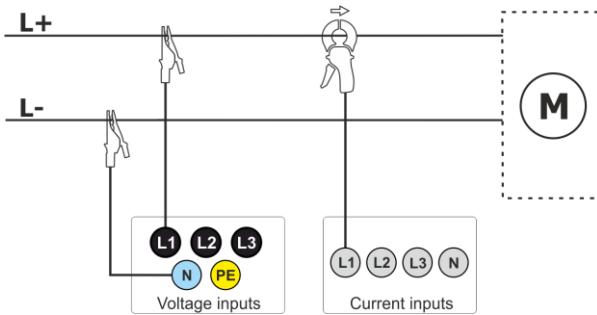

Fig. 25. Wiring diagram – DC system.

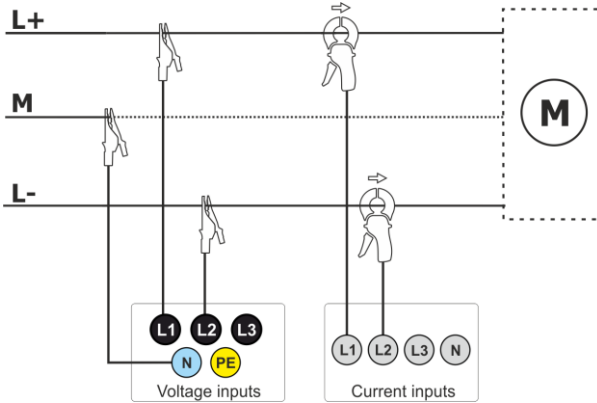

Fig. 26. Wiring diagram – DC+M system (bipolar).

2.10 Inrush current

The function enables user to record half-period values (RMS $\frac{1}{2}$) of voltage and current until the measurement memory is full (approx. two weeks of recording for 2 GB of memory). The user can stop the recording at any time. Before the measurement, set aggregation time at $\frac{1}{2}$ period. Other settings and measurement arrangements are not limited.

The second way to measure the inrush current is to set the current event to the selected current value (in *Sonel Analysis* select **CURRENT** screen ► **BASIC** ► **LOG EVENTS**). After exceeding the set current value, the analyzer will record a waveform (up to 1 s) and an RMS $\frac{1}{2}$ graph (up to 30 s).

2.11 Example of use

The procedure presented below shows how to make a sample measurement with the analyzer ('step by step'): from connecting the device to generating the measurement report. It provides guidelines how to quickly start to operate the analyzer and *Sonel Analysis* software. It is assumed that *Sonel Analysis* software is already installed. The example assumes the use of PQM-703 analyzer. If using an analyzer without transient measurement capability, skip settings that refers to transient measurement.

Scenario: single-phase measurement acc. to user settings.

Measurement scenario is as follows: the user wants to measure voltage parameters of 1-phase network 230 V 50 Hz. The measurement is to be made with averaging equal to 1 second. The following parameters are to be recorded:

- average values of voltage, THD and harmonics,
- frequency,
- voltage event detection should be turned on and set at level of: 105% U_{nom} for swell, 95% U_{nom} for dip, 10% U_{nom} for interruption. When an event is detected, the waveform and RMS_{1/2} graph must be recorded.
- waveshape variations events should be enabled, with the threshold set at 10%, and the hold-off time for recording next events set at 5 seconds,
- detecting events resulting from changes in the phase angle, with the threshold set at 10°,
- transients should be activated at the lowest possible voltage threshold of 50 V (the most sensitive setting) and a sampling frequency of 10 MHz. Transient graph recording should be activated.

After the measurement, generate timeplots of measured parameters and a sample measurement report. Data should be saved for further analysis.

How to perform the measurements:

Step 1: Connect the analyzer to the tested network, as shown in Fig. 16. Connect inputs L1, N, and PE (for transient measurements). Current probes do not need to be connected, as the current measurement is not required. Power supply of analyzer (red wires) may be also connected to the tested network, or other power supply that is compatible with analyzer's power adapter input ratings, to avoid battery discharge during recording.

Step 2: Turn on the analyzer by pressing  button. Screen 1 should be displayed as shown in Fig. 5.

Step 3: Connect the analyzer to a PC via USB cable. If this is the first connection, wait to install the drivers of the analyzer.

Run "*Sonel Analysis*" program.

Step 4a: If after launching *Sonel Analysis* the **STARTUP WINDOW** is displayed, select **SET UP AND RECORDING** and then **ADVANCED RECORDING SETTINGS** - move to **4c** (below).

Step 4b: When **STARTUP WINDOW** is not displayed, click **RECORDING SETTINGS** button on the toolbar of *Sonel Analysis* or select **ANALYZER→RECORDING SETTINGS** from the menu. In the displayed window, select **ADVANCED RECORDING SETTINGS**.

Step 4c: A window will be displayed, showing the detailed configuration of the analyzer. Click **RECEIVE SETTINGS** button. This will result in reading the current configuration of the measurement points saved in the analyzer.

Step 5 (optional): If the analyzer has not been previously connected to the program (status at the bottom bar of *Sonel Analysis* indicates **DISCONNECTED** in red, when the analyzer is not connected to the program), then clicking **RECEIVE SETTINGS** will result in displaying window for connecting with the analyzer. This window should display one analyzer found (if not, click **SEARCH AGAIN**). Select

2 Operation of the analyzer

the found analyzer by double-clicking it. If the analyzer has not been added yet to the database of the analyzers in the program, a window will be displayed prompting user to enter PIN code of the analyzer. Default factory code is "000" (three zeroes). Proper connection is confirmed by displaying window **CONNECTION ESTABLISHED** (the analyzer screen will display **CONNECTED TO PC (USB)**).

Step 6: Then a message will be displayed asking user to confirm the read-out of settings. Click **OK** and then in the confirming window also **OK**. Doing this will upload the settings of all four configurations - they may be viewed and changed in **ANALYZER SETTINGS** window.

Step 7: Checking allocation of the memory. In the top part of recording settings window, the program displays panel **LOCAL**. The first item in this panel is **MAIN SETTINGS**. In the main part of the window, one of the three tabs is displayed (**ANALYZER TYPE**, **Memory allocation**, **GPS SYNCHRONIZATION**). Display **MEMORY ALLOCATION** tab and ensure that there is enough space (memory allocation) on the memory card (default is 25%) for **CONFIGURATION NO. 1**. When the space is very little or set at 0%, adjust it using sliders.

Step 8: Modify the settings of **CONFIGURATION NO. 1** - carry out this operation as presented in the scenario above. In **LOCAL** panel click: **CONFIGURATION NO. 1**, to modify the settings for this point and expand the tree of cards for this point (double-clicking **CONFIGURATION NO. 1** automatically expands the tree). The following items should be displayed after expanding: **STANDARD, VOLTAGE, CURRENT, POWER AND ENERGY, HARMONICS, INTERHARMONICS**.

Advanced analyzer settings []*

Local

Configuration No. 1

Standard 1

Voltage 2

Current 3

Power and energy 4

Harmonics 5

Interharmonics 6

Configuration No. 2 7

Configuration No. 3 8

Configuration No. 4 9

Send settings 10

Receive settings

Analyzer

General settings

Configuration No. 1

Configuration No. 2

Configuration No. 3

Configuration No. 4

Measurement point name 11

Voltages

Mains nominal values

Voltage Vn 230/400 V

Frequency fn 50 Hz

Mains system 3-phase 4-wire Wye 3

Triggering and averaging

Averaging period: 10s

Triggering: Immediate

Additional measurements

N-conductor current

Measured

Calculated

N-PE voltage

Events detection hysteresis 12

2,00 %

Probes type

F-1, F-2, F-3

4 max = 3,00 [kA]

13 Current limit

0,02 % [0,6A]

5 Voltage transducers

Primary 100,00 V

Secondary 100,000 V

Ratio 1,00

6 Current transducers

Primary 1,00 A

Secondary 1,0000 A

Ratio 1,00

Scheduled logging

Period	Start	Stop	Span
	09/08/2017 12:45:58	09/08/2017 12:45:58	
	09/08/2017 12:45:58	09/08/2017 12:45:58	
	09/08/2017 12:45:58	09/08/2017 12:45:58	
	09/08/2017 12:45:58	09/08/2017 12:45:58	

Estimated memory usage 0,0% (0,0/1 874MB)

Total time span 0s

Fig. 27. Main settings of the recording configuration.

To change the main settings of the recording configuration, single-click **CONFIGURATION NO. 1** at **LOCAL** panel. The screen should look as shown in Fig. 27.

Set the following items:

- mains system (element **3** as in Fig. 27) as a single-phase,
- nominal voltage **1** at 230/400 V,
- nominal frequency **2** at 50 Hz,
- averaging period **8** at 1 s,
- triggering **9** at Immediate,
- event detection hysteresis **12** at 1.5%,
- probe type **4** set to **NONE**,
- voltage transducers **5** and **N-PE VOLTAGE** (in section **ADDITIONAL MEASUREMENTS 7**) set as unchecked,

In the upper part of the window select the second tab **ADDITIONAL**, where sliders may be used to set the required time of recording waveforms and RMS_{1/2} graphs for events and recording times for transient graphs. These times should be set according to individual preferences.

Then select **Standard** card from the tree with settings and ensure that **ENABLE LOGGING ACCORDING TO STANDARD** box is not checked.

Adjust settings at **VOLTAGE** card and **BASIC** tab, as shown in Fig. 28.

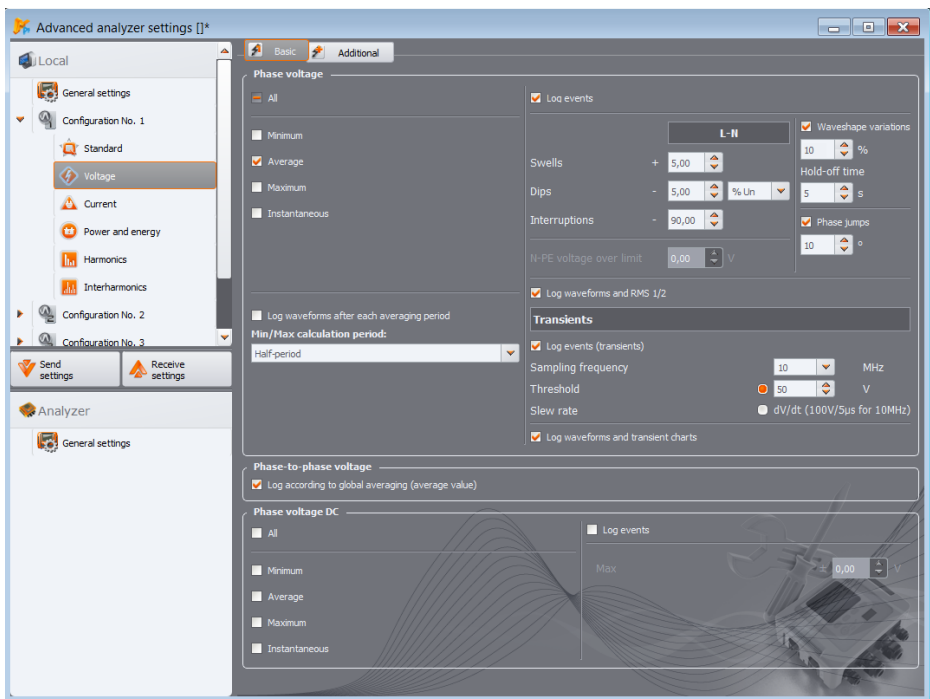

Fig. 28. Settings for 'Voltage' card in scenario.

2 Operation of the analyzer

At **ADDITIONAL** card select only the average value for the frequency, and uncheck other boxes.

At **HARMONICS** card and **VOLTAGE** tab select fields for THD average values and for voltage harmonic amplitudes - uncheck other boxes. List **THD CALCULATED FROM** may be set according to own requirements.

At **INTERHARMONICS** card and in **VOLTAGE** and **MAINS SIGNALLING** uncheck all the boxes.

Step 9: Settings of the measurement point has been properly prepared. The next step is to send the settings to the analyzer. The memory card will be formatted. To do this press **SEND SETTINGS** button. In the displayed window confirm the deletion of all data on the memory card of the analyzer and sending the new settings. If successful, a window will be displayed, to enable you immediately start recording. Select **YES** and the window **CONTROL** will be displayed.

Step 10: If window **CONTROL** is not open (option **NO** selected), then on the toolbar click **CONTROL**, or select it from menu **ANALYZER→CONTROL**. The analyzer is ready to start recording acc. to specified settings. To begin recording at the **CONFIGURATION NO. 1**, in the displayed window **CONTROL** select from **CURRENT CONFIGURATION** the first position, that is *configuration no. 1* (this field contains a list of names given to individual configurations) and start recording by clicking **START**. Start of the recording will be indicated by the analyzer by triple beep and recording is indicated on the display of the analyzer by flashing **P1** symbol in the upper left corner. Recording may be continued for any length of time; connection of the program with the analyzer is not required. During the measurement, disconnect L1 lead from the tested network to simulate a voltage dip.

Step 11: Stop recording and upload data for the analysis. Display **CONTROL** window (if not open yet). Click red button **STOP**. Click **ANALYSIS** icon on the toolbar (or select **ANALYZER→ANALYSIS** from the menu), to open the window for loading previously recorded data for analysis. The window shows four bars of memory used for each of the measurement points. Check the box next to the bar of measurement point No. 1. The size of recorded data is shown in the right side of bar. After selecting it, **LOAD DATA** button is activated - press it. A window will appear showing data loading progress. After loading all data, a window is displayed for saving downloaded data into the disk. It is recommended to save the data to a desired location on the disk, in order to retrieve it for further analysis. Indicate the location on the disk, name the file and click **SAVE**. In the displayed window click on the horizontal bar indicating time of recording placed under text **CONFIGURATION NO. 1 (USER)** (after clicking it turns orange) and then click **DATA ANALYSIS**.

Step 12: Data analysis. In the main window of data analysis four main buttons are available: **GENERAL** (default view after loading data), **MEASUREMENTS**, **EVENTS**, **CONFIGURATION**. In **GENERAL** view, on the right side, icons are displayed representing individual measurements, event and recorded waveforms in the timeline. This graph with a large amount of data may be freely enlarged to get more details.

Click **MEASUREMENTS** button to display table with the values of all measured parameters, according to selected averaging time. In this scenario, the selected averaging time is equal to 1 second, therefore every second the analyzer recorded voltage THD and harmonics (frequency is always measured every 10 seconds). Each line contains the data recorded in the consecutive second and each column shows individual parameters.

After pressing **EVENTS** you may view all the recorded events. In this scenario, the following voltage events were recorded: swell, dip, interruption and transients. Each row in the table corresponds to one detected event. When for a given event graphs are available (e.g. waveforms and RMS_{1/2} graphs), as in this scenario, the last column contains the icon of saved graphs. After clicking it, the user may display graphs related to a given event.

Step 13: Display the time plot for voltage and THD. To generate the graph, go to **MEASUREMENTS** (click **MEASUREMENTS** button), select column headings for L1 voltage, THD L1 (columns will be

highlighted along with the *Time* column) and then click **PLOTS** and choose **TIME PLOT**. A window will be displayed with a graph containing two timeplots: L1 voltage and THD. The graph may be freely enlarged, using the three markers mark specific points on the graph and read the parameters of indicated points. The graph may be saved (in selected graphic format) by clicking **SAVE** icon on the top toolbar.

Step 14: Displaying graphs with harmonics. Two types of graphs may be displayed for harmonics. The first one is a graph of recorded harmonics during the recording period. To display the graph, first select the time column and then the columns of selected harmonics (e.g. third and fifth order) and **CLICK PLOTS** → **TIME PLOT**.

The second type of the graph is a bar graph of harmonics. It shows all the harmonics in selected 1-second interval (one row). To generate it, first select the desired cell from the time column and then select the column of any harmonic, click **PLOTS** and choose **HARMONICS**. In the same manner, the user may also select the time interval by dragging time column cells. Then a graph is shown with average values of harmonics in the specified time period.

Step 15: Generating measurement report. In order to generate a report containing values of required parameters, select the columns of these parameters (always select the time column first), and then click **REPORTS** and select **USER REPORT**. Click **PREVIEW** in the displayed window to see saved data. **SAVE** button saves data in a format specified by the user (PDF, HTML, TXT, CSV).

Step 16: Checking events. If the analyzer, during recording process, detects any event, it will be displayed in a table in **EVENTS** view. The row describing the specific event displays time of the event (start and end), extreme value (e.g. minimum voltage during the dip), waveform and $RMS_{1/2}$ graph when the event was voltage- or current-related. In this scenario, event graphs were activated in settings, therefore when the analyzer detects any event, the last column of the table (with **WAVEFORM** header) should include a graph icon. Click it to display the graphs.

2.12 Time Synchronization

2.12.1 Requirements of IEC 61000-4-30

The analyzer has a built-in GPS receiver, whose main purpose is to synchronize the analyzer clock with an atomic clock signal distributed via GPS satellites. Time synchronization of the analyzer with UTC is required by IEC 61000-4-30 standard for Class A for marking the measurement data. Maximum error cannot exceed 20 ms for 50 Hz and 16.7 ms for 60 Hz. Such action is necessary to ensure that different analyzers connected to the same signal provide identical read-outs. Synchronization with UTC is also needed when the network of analyzers is dispersed. When the source of the time signal becomes unavailable, an internal real-time clock has to ensure the accuracy of time measurement with accuracy better than ± 1 second to 24 hours, but even in these conditions, to ensure the compliance with class A, the accuracy of measurement must be the same as previously specified (i.e., max. 1 period of mains).

2.12.2 GPS receiver

A GPS receiver and antenna is installed inside the analyzer, in order to receive GPS signal outdoors without any additional accessories. The antenna is installed in the lower left corner of the casing under the top cover (in a place where GPS logo on the sticker is applied). To enable the time synchronization of the analyzer inside buildings, the analyzer must be connected to an external antenna (optional accessory), with a cable of 10 m and installed outside of the building. The analyzer detects the external antenna and switches into the receiver mode instead of using additional internal antenna.

GPS synchronization time depends on weather conditions (clouds, precipitation) and on the location of the receiving antenna. The antenna should be provided with high "visibility" of the sky in order to obtain the best results. To read the time with the required accuracy, the GPS receiver must first determine its own current geographical location (it must "see" at least 4 satellites - position and altitude). After determining the position and synchronizing time to UTC, the receiver enters the tracking mode. To ensure time synchronization in this mode, the visibility of only one GPS satellite is required. However, to determine the analyzer position (when it is moved), still four satellites must be available [seen] (3 satellites if GPS does not update the altitude data). This is important for example in anti-theft mode, when the device needs continuous position information.

2.12.3 Data flagging concept

The analyzer saves measurement records along with the flag indicating the lack of time synchronization. If for the whole averaging period the analyzer was synchronized to UTC, then the flag

is not turned on and during data analysis the icon indicating the lack of synchronization  is not displayed. The absence of this icon indicates full compliance of gathered data with Class A in terms of time marking. Synchronization with UTC is also indicated on the screen of the analyzer by green date and time on the top bar.

When the analyzer was initially synchronized to UTC (GPS status on the analyzer screen displayed as **YES**) and later the signal was lost (**NO SIGNAL** status), this does not mean that the analyzer immediately lost the synchronization of its clock. In fact, for some time (even a few minutes or more) internal timing accuracy is sufficient to meet the requirements of IEC 61000-4-30 in part relating to the accuracy of determining time data. This is because the internal clock of the analyzer is very slow in de-synchronizing from UTC time (due to no GPS signal), and the error does not exceed a few milliseconds for an extended period of time. Thus, despite the "No signal" status, data will continue to be saved without the flag signalling the lack of synchronization to UTC. Only when the error exceeds the limit value the flag will be turned on.

2.12.4 Time resynchronization

As the availability of the GPS signal cannot be guaranteed on a permanent basis, it is necessary to ensure proper management of internal time when the GPS signal becomes available and when it differs from the internal time of the analyzer.

When no recording is on - the situation is simple - after receiving the satellite time, the analyzer clock automatically synchronizes with it without any additional conditions.

When the recording process is on, a sudden change of the internal time may lead to a loss of measurement data when time is reset, or it may create a time gap in gathered data, when UTC time is ahead of the analyzer time. To prevent this, a slow synchronizing mechanism was introduced to synchronize the internal analyzer time with UTC time. The implementation of this concept is based on the deceleration or acceleration of the internal analyzer clock in such a manner that after a time the two clocks - internal and GPS - are equalled and achieve synchronization. The advantage of this solution is the fact that there is no data loss or discontinuity.

The user has the option to set two configuration parameters that affect the resynchronization during the recording process. One of them (resynchronization factor) defines the speed of the synchronization. The lower is the factor value, the longer is resynchronization, but the length of the measurement intervals will be close to the averaging time.

Despite the aforementioned disadvantages of an abrupt time change, there is an option to carry it out even when recording process is active. A threshold is defined in seconds (**TIME RESYNCHRONIZATION THRESHOLD** parameter), to set the minimum difference between internal and UTC time at which the abrupt (one-step) time change will be performed.

Note

*Abrupt change of time during the recording process may lead to irreversible loss of recorded data, therefore it is advised to use the slow resynchronization mode (**TIME RESYNCHRONIZATION THRESHOLD** parameter set to zero).*

To avoid the problems with time measurement during recording, please remember the following issues:

- The analyzer must have properly set its time zone and the time displayed on its screen must be precisely compatible with local time (if there is no GPS signal before starting the recording).
- Turn slow resynchronization of time, by setting **TIME RESYNCHRONIZATION THRESHOLD** parameter to zero value and set resynchronization factor at a low value (e.g. 25% or less).
- If possible, before starting the process of recording, receive the GPS signal to synchronize the analyzer time to UTC. This will ensure the least possible timing errors during the recording and a fast tuning time in case of a temporary loss of GPS signal.
- In order to ensure the compliance of the whole measurement with requirements of IEC 61000-4-30 in terms of time marking for devices of Class A, the internal analyzer clock must be synchronized to UTC, and GPS signal must be available for the whole process of recording.

2.13 GSM communication mode

2.13.1 General information about GSM connection

Built-in GSM modem ensures wireless communication with the analyzer from almost any location with Internet access. Similarly as in case of USB and OR-1 connection, this mode provides the user with a full control of the analyzer - the user may view current data, start and stop recording, read the data for analysis, etc. To use this mode, the analyzer must be equipped with a SIM card of the following service parameters:

- General Packet Radio Service (GPRS)
- static public IP address,
- SMS option to send alarm messages.

Note

Ordinary SIM card removed from a cell-phone cannot be used with the analyzer. GPRS in the analyzer requires a non-standard static IP address service, reserved only for a given SIM card. This static IP address ensures that the analyzer has one permanent address in the Internet. This type of service is commonly used for transmission "machine-to-machine" (M2M) used e.g. in industry transmissions for monitoring and exchanging measurement data between devices.

The communication is performed in the following manner:

- the modem connects to a GSM network, and then log on to the Internet,
- the modem initiates TCP/IP server service with IP address assigned by the service provider. Usually, the port number used by the analyzer is 4001. The analyzer is present in the Internet with this IP and port.
- PC from which the user tries to connect with the analyzer via GSM modem must have access to the Internet.
- "SoneI Analysis" software while searching for analyzers, tries to connect to those analyzers that have IP number configured in the data base (additionally the user must enable **TCP/IP OVER GSM** in program settings). Only port 4001 of a remote host is checked by default.
- If an analyzer is found under typed address and its serial number match the serial number of an analyzer in the database, then the device will be shown in the list of found devices.
- After connecting the communication will be performed via the Internet. After completing the connection, the software closes the connection with the analyzer, which enters a "stand-by" mode waiting for a client connection.

2.13.2 Modem Configuration

In order to configure the SIM card and modem in the analyzer, the user must obtain the following data from the data transmission service provider:

- PIN code for SIM card
- PUK code for SIM Card - for emergency cases, when SIM card is locked after repeated attempts of enter wrong PIN,
- IP number assigned to SIM card (it must be a static number),
- APN (*Access Point Name*),
- user name and password (optional, usually not required).

Configure the analyzer for GSM connectivity in the following manner:

- connect to the analyzer via a USB cable. If the analyzer is not present in the database it should added to it.
- it is necessary to check whether the modem is turned on. To do this, select **ANALYZER** → **ANALYZER SETTINGS** from the program menu and go to **WIRELESS CONNECTIONS** card. Check whether **GSM TRANSMISSION AVAILABLE** option is active - enable it if it is not.
- disconnect the USB connection and use buttons to select screen **<8>**. If the modem is switched on, but no SIM card is inserted, line **GSM** will show message **No SIM CARD**.
- insert SIM card into the slot on the side of the device The slot is of "push-push" type (push gently to remove the card - it will be pushed out by the device). The analyzer will detect inserted card and will attempt to connect to the network.
- if PIN code of the SIM card has not been configured, the analyzer displays message **INVALID PIN CODE OF SIM CARD**. This message will also be displayed on screen **<8>**. It means that the SIM card rejected PIN, which was used by the analyzer to attempt the communication. This is normal when you insert a new card into the analyzer.
- To configure missing parameters required to perform GSM transmission, the user must re-connect PC to the analyzer via USB and choose **OPTIONS** → **ANALYZER DATABASE** from the program. In the analyzer database enter the option for editing the analyzer settings (click the line with the serial number of appropriate analyzer and click **Edit**). Click **CHANGE GSM SETTINGS** button.
- In the displayed widow enter the following data: IP number - in **IPv4** field (it should be provided by the service provider) **APN**, username and password (if required and provided by the service provider). Confirm new data by pressing OK.
- Then a pop-up will be displayed, asking you to enter PIN code of the SIM card. Enter the code supplied with the SIM card and confirm it by clicking OK.
- If you have entered the correct data, the analyzer will use it to properly log into the GSM network. The connection status may be checked in screen **<8>** of the analyzer (USB session must be disconnected). Correct connection is indicated by GSM status: "**READY, <connection type>**". *<connection type>* depends on the location and type of data transmission services in the area.
- the correct order of the messages displayed on screen **<8>** when connecting to GSM network is as follows:
 - **TURNING ON...**
 - **CONNECTING TO NETWORK...**
 - **CONNECTING TO INTERNET...**
 - **READY, <connection type>**

2 Operation of the analyzer

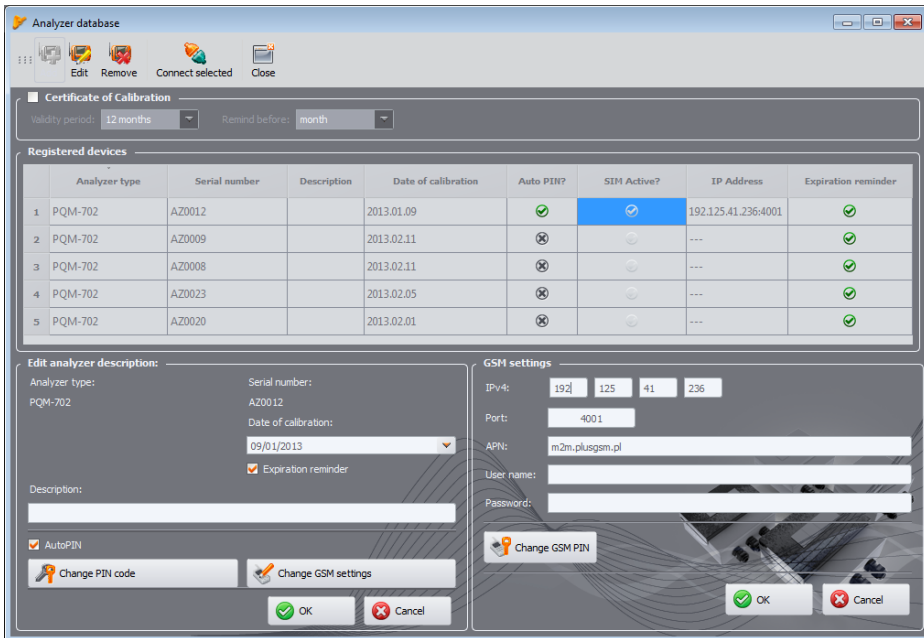

Fig. 29. Entering GSM settings in the analyzer database

If you remove the SIM card from the slot, the analyzer will display error message **NO SIM CARD**. This message is repeated during next activations of the analyzer. Removing the SIM card while the analyzer is in operating mode, it is not recommended, as it prevents correct analyzer logging off from the GSM network.

Note

After any change in GSM settings, automatic modem restart is initiated.

2.13.3 Checking GSM connection

If status screen <8/9> shows the status of GSM modem as "**READY**, <connection type>", it means that a connection from a remote PC may be performed via Internet. The user may perform a test connection to verify the connectivity with "*Sonel Analysis*":

- In the program settings, check whether the search of the analyzers via GSM network is enabled: select **OPTIONS** → **PROGRAM SETTINGS** → **MEDIA SETTINGS** → **ACTIVE MEDIA**. Check **TCP/IP OVER GSM** box.
- The analyzer that is chosen for the connection must be entered into the Analyzer database (when the modem was configured as described in sec. 2.13.2 this will be ensured).
- Disconnect any connection to the analyzer (USB or OR-1).
- Perform a search for the analyzer, selecting any available method (e.g., by clicking **LIVE MODE**). The search list should show the analyzer with note "**(GSM)**". Select the analyzer and click **SELECT**.

- After a while, the screen should display the desired window (e.g. **LIVE MODE**) and the status bar should display **CONNECTED** message. Also the analyzer screen will display **CONNECTED TO PC (GSM)** message. The connection attempt was successful.

2.13.4 Possible problems with GSM settings and troubleshooting

Problem: The search progress bar quickly reaches 100% and no analyzer is found.

Possible cause: It may indicate that GSM search is disabled in program settings or in the analyzer database.

Solution: from program menu select **OPTIONS → PROGRAM SETTINGS → MEDIA SETTINGS → ACTIVE MEDIA**. Check **TCP/IP OVER GSM** box.

Problem: The search progress bar in a few sec. reaches 100% and no analyzer is found.

Possible causes:

- 1) The analyzer is turned off or its GSM is inactive / not configured.
- 2) IP address of the analyzer does not match the address entered into the database of analyzers.
- 3) The analyzer has active GSM connection with another client or temporary network problems.

Solution:

- 1) When the analyzer is available check the status of GSM modem on screen **<8>**. If the status is **DISABLED**, then select: Select **ANALYZER → ANALYZER SETTINGS** from the program menu, go to **WIRELESS CONNECTION** card and check whether **GSM COMMUNICATION ENABLED** is enabled (if not, enable it). Check settings of the modem.
- 2) Check whether the correct IP address is entered to the database of analyzers.
- 3) Try again in a few minutes.

Problem: Despite correct status ("**READY, <connection type>**"), after the search, the analyzer is not displayed on the list. Option **GSM COMMUNICATION ENABLED** is enabled and the analyzer is properly configured in the database (including IP number).

Possible cause: TCP 4001 port is blocked - it is used for communication through a firewall installed on the PC or in the server of internet service provider.

Solution: check whether TCP 4001 port in program settings is not blocked. If it is not, please contact your local network administrator.

Problem: When a SIM card is inserted into the analyzer, message **INVALID IP** is displayed.

Possible cause: IP number assigned by the network is different than the one configured in the analyzer.

Solution: Check whether the analyzer database includes the correct IP number, as specified by the provider. In the analyzer database enter settings and select **CHANGE GSM SETTINGS**. Enter the correct IP address and confirm. Disconnect the analyzer and using the screen of GSM connection status to check whether the analyzer properly connects to the Internet. If this does not help, check whether the inserted SIM card is correct.

Problem: The analyzer reports an error of **INVALID PIN CODE OF SIM CARD**.

Possible cause: PIN code used by the analyzer to unlock the SIM card is incorrect. This may be caused by replacing SIM cards, or changing the PIN code of the card by an external device.

Solution: After connecting the analyzer via USB cable, enter the analyzer database and select **CHANGE GSM SETTINGS**, and then **CHANGE GSM PIN**. Enter any of the four digits in **PREVIOUS PIN** (this field is ignored in this case), and then enter the same correct SIM code in the two fields below. Save the settings. Disconnect the analyzer and screen **<8>** will be displayed by the analyzer to check the status of GSM (whether the connection available or not).

Problem: Analyzer reports a GSM error by displaying **PUK REQUIRED**.

Possible cause: The card inserted into the analyzer is blocked due to several attempts of entering incorrect PIN code. Unlock the SIM card by entering PUK code.

Solution: After connecting the analyzer via USB cable, enter the analyzer database and select option **CHANGE GSM SETTINGS**. Select **CHANGE GSM PIN**. This should open a window allowing you to enter PUK code and new PIN code. Enter the codes and confirm. Disconnect the analyzer and on screen **<8>** check the status of GSM (whether the connection is made properly).

The card may be also unlocked by inserting it into any mobile phone and entering PUK code and a new PIN code.

Note: several attempts to enter incorrect PUK code will result in irreversible blocking of the SIM card!

Problem: The analyzer reports GSM errors: **NETWORK ERROR, SMS ERROR, NO NETWORK** or other.

Possible Cause: One of GSM network errors occurred. It may be caused by entering wrong phone number for SMS notifications or temporary loss of network coverage.

Solution: In case of SMS error, check the correctness of the entered phone number. In other cases, do not take additional steps. The analyzer will try to repeat the operation after some time (e.g. 5 minutes).

2.14 Wi-Fi communication mode PQM-710 PQM-711

2.14.1 General Information

PQM-710/711 analyzers are equipped with Wi-Fi module working in IEEE 802.11 b/g standard and n single stream.

Wi-Fi module in the analyzer may operate in two modes:

- **Access Point (AP)** – the analyzer distributes its own Wi-Fi network. Devices connecting to the analyzer operate in client mode. This mode is available in analyzers with 1.30 firmware version or later.
- **client** – the analyzer connects to an existing external access point (access point may be configured, e.g. in the tablet supplied with the analyzer or it may be an external router with a Wi-Fi access point).

2.14.2 Factory configuration

The factory Wi-Fi configuration of the tablet and the analyzer is as follows:

- Operation mode: the analyzer acts as an Access Point.
- Analyzer settings:
 - Network SSID: *analyzer_model_analyser_serial_number* (e.g. PQM-710_BR0001),
 - channel: 10,
 - IP number of the access point: 10.0.71.1,
 - Subnet mask: 255.255.255.0,
 - Automatic assigning of IP addresses (DHCP): enabled
 - WPA2-PSK encryption enabled, default key: "12345678".
- Configuration of the tablet (client):
 - IP assigned automatically by the access point: 10.0.71.X (where X is in the range of 2...254), gateway 10.0.71.1.
 - WPA2-PSK encryption enabled, default key: "12345678".

2.14.3 Access Point mode

In Access Point mode (AP), the analyzer distributes own Wi-Fi sub-network with a fixed name (SSID). The default settings of the analyzer are presented in sec. 2.14.2. External devices (e.g. PCs) may connect to the analyzer if they are equipped with a compatible Wi-Fi interface operating in client mode.

Only one client at a given time may be connected with the analyzer.

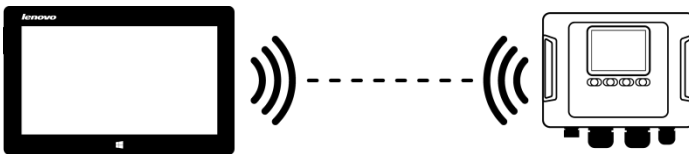

Fig. 30. Direct connection tablet/PC (client) ↔ analyzer (AP).

Access Point operating mode is indicated by the analyzer on screen <10> in the first row - next to **Wi-Fi** there is also **"AP"** displayed. This screen displays the following information:

- Status of the connection with the client (e.g. **READY**, **CLIENT CONNECTED**),
- MAC address of the analyzer's Wi-Fi module,
- IP address assigned to the access point,
- The current name of the distributed network (SSID).

2 Operation of the analyzer

The default Wi-Fi channel for analyzer operation (channel 10) may be changed when the channel is used by more devices, which may result in reduced bandwidth and mutual interference. To change the channel in the range of 1..13, assign a new SSID name, which ends with "**_chX**" (underscore, small letters "**ch**" and channel number), where **X** is a number indicating the channel in the range from 1 to 13. An example of SSID name, which changes the default channel to channel 5 is "PQM-711_BS0001_ch5".

When the analyzer is set in the access point mode and is ready to work, you can connect to the network distributed by the analyzer. In Windows OS, display the network connection window, find the SSID name of the analyzer on the list of available wireless networks and select Connect command. An example of such a window is shown in Fig. 31.



Fig. 31. Window of wireless network connection in Windows OS.

To connect, you need to enter the network password. It is recommended to change the default password. The password must contain at least 8 characters. If you successfully connected to the analyzer's network, the next step is to run *SoneI Analysis* software and checking the communication.

2.14.3.1 Configuring Wi-Fi connection via USB connection

The user can modify the default access point settings of the analyzer using *SoneI Analysis* software. You need to connect the analyzer via a USB cable.

Configure the analyzer in the following manner:

- Connect to the analyzer via a USB cable.
- Perform the analyzer search, e.g. by selecting **ANALYZER** → **ANALYZER SETTINGS** (F4) and connect to the analyzer.
- Go to **WIRELESS CONNECTIONS** tab (Fig. 32) and check whether **WI-FI COMMUNICATION ENABLED** is active. If it is not, enable it.

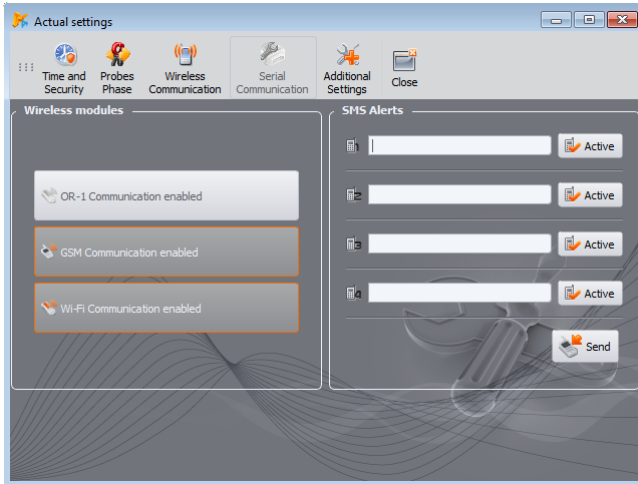

Fig. 32. Screen for settings of the analyzer, available wireless transmission media.

- Select **OPTIONS**→**ANALYZER DATABASE** (F3). In the analyzer database enter the option for editing the analyzer settings (select the line with the serial number of the analyzer and click **EDIT**). In the displayed menu, click **CHANGE Wi-Fi SETTINGS**.
- Set the **MODE** switch in **ACCESS POINT** position.
- Enter in the following order (field **NETWORK NAME (SSID)**) and network password twice (fields **NEW PASSWORD** and **CONFIRM PASSWORD**). The password must contain at least 8 characters.
- Use **RESTORE DEFAULT SETTINGS** to fill fields with default values presented in sec. 2.14.2.
- After approving the settings with **OK** button, the analyzer restarts the Wi-Fi module, and after a moment it should be ready to connect to the client with the new settings. Readiness to work and SSID name may be verified on screen <10> of the analyzer after terminating the USB connection.

2 Operation of the analyzer

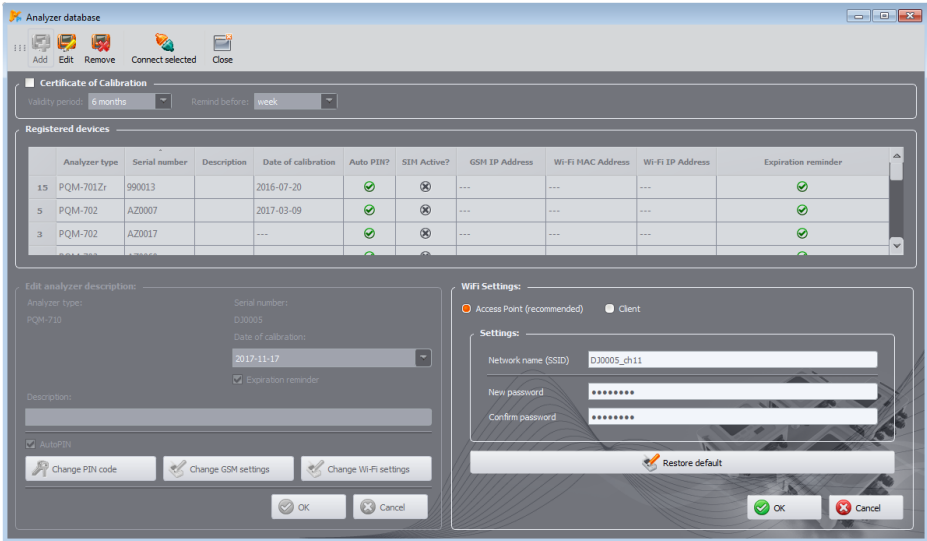

Fig. 33. Screen of configuring Wi-Fi access point.

2.14.4 Client mode

In client mode an operation in a local network (Fig. 34) or via the Internet (Fig. 35) is possible. When the tablet used has a software for setting-up the software access point, a direct connection tablet ↔ analyzer is also possible (Fig. 36 ,Fig. 37).

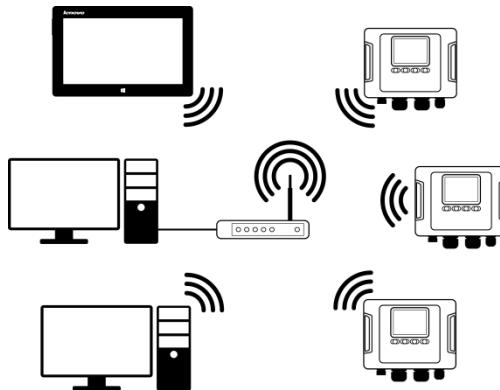

Fig. 34. Indirect connection via Wi-Fi router, local network, analyzers in client mode.

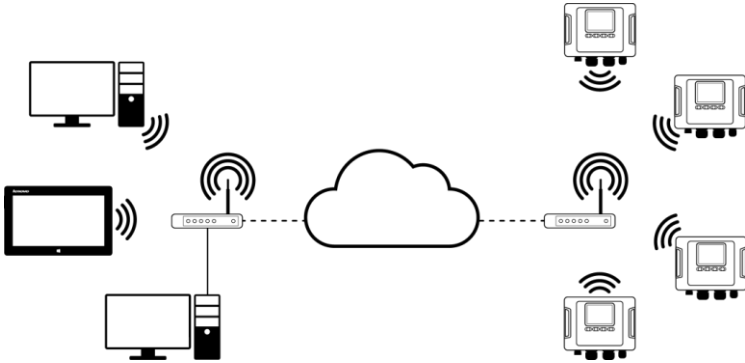

Fig. 35. Connection via Internet. Analyzers in client mode

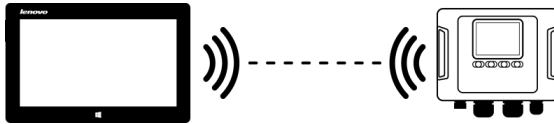

Fig. 36. Direct connection tablet (AP) ↔ analyzer (client). Requires a tablet with software access point capability (not included in software package provided by Sonel S.A.)

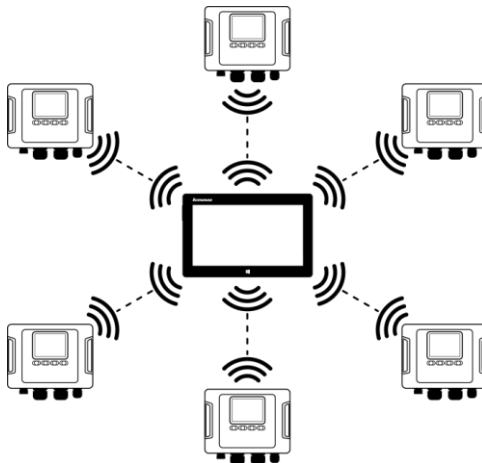

Fig. 37. Direct connection: tablet (AP) ↔ multiple analyzers (clients). Requires a tablet with software access point capability (not included in software package provided by Sonel S.A.)

2 Operation of the analyzer

In configurations with external router an operation in open or WPA/WPA2-PSK secured network is possible. When working in open networks the **KEY** field in **ANALYZER DATABASE** must be empty.

When connected to an access point, the analyzer starts TCP/IP server connections with static IP address or with an address assigned by DHCP server of the access point. The port used in the local network and for direct connections is 4002.

Connecting to the analyzer via the Internet requires a Wi-Fi router properly configured by the network administrator (redirecting traffic from the local network to the public network).

The analyzer, which has no access point within its range, remains in scanning mode of 2.4 GHz Wi-Fi band.

Remote connection of *Sone/ Analysis* software via Wi-Fi is possible, when this mode is active in software settings (**PROGRAM SETTINGS** → **ACTIVE MEDIA**).

2.14.4.1 Configuring Wi-Fi connection via USB connection

To properly configure the connection, the following elements will be required:

- Access Point Name (**SSID**).
- Password (**KEY**) in case of secured networks.
- **EXTERNAL IP ADDRESS** and **EXTERNAL PORT**. These parameters are required to work in a different subnetwork than the tablet (computer), especially for connecting to the Internet.

Configure the analyzer in the following manner:

- Connect the tablet (computer) with the analyzer via a USB cable.
- Perform the analyzer search, e.g. by selecting **ANALYZER** → **ANALYZER SETTINGS** (F4) and connect to the analyzer.
- Go to **WIRELESS CONNECTIONS** (Fig. 32) and check whether **WI-FI COMMUNICATION ENABLED** is active. If it is not, enable it.
- Select **OPTIONS** → **ANALYZER DATABASE** (or F3 key). In the analyzer database enter the option for editing the analyzer settings (select the line with the serial number of the analyzer and click **EDIT**). In the displayed menu, click **CHANGE WI-FI SETTINGS**.
- Set the **MODE** switch in **CLIENT** position.
- Enter the following data: the access point name (**SSID** field) and in case of a secured network tick **MODIFY** box and enter the password (**KEY** field). In case of a non-secured network, **KEY** field remains empty, but **MODIFY** box must be ticked.

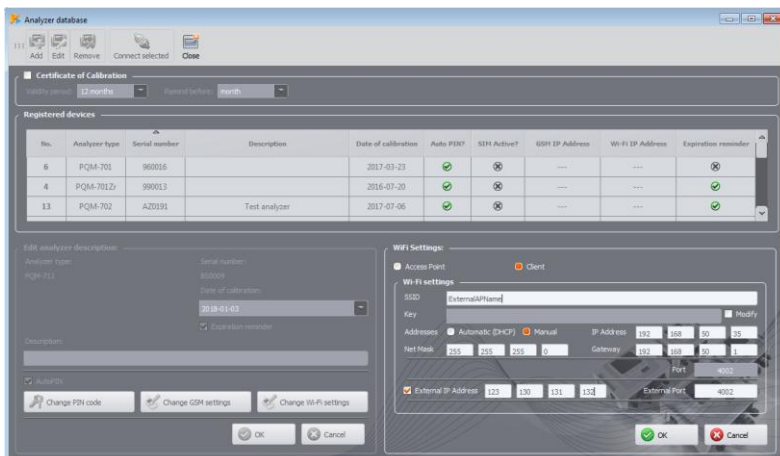

Fig. 38. Example configuration of Wi-Fi connection in client mode (external IP).

- Select the method for assigning IP address via access point. In case of selecting manual mode – enter appropriate values into fields: **IP ADDRESS** , **NET MASK** and **GATEWAY**. In automatic mode, select **DHCP**.
- **PORT** field is not editable, it is always 4002.
- In case of operating in other subnetworks (the Internet), fill-in **EXTERNAL IP ADDRESS** and **EXTERNAL PORT** fields. For a direct connection (tablet ⇔ analyzer), and for working in a local network (tablet ⇔ Wi-Fi router ⇔ analyzer) these fields must be left inactive. *Sonel Analysis* scans the network automatically and updates these fields after detecting the presence of an analyzer.
- Confirm the settings by pressing **OK**. This will send new data to the analyzer.
- If the correct data have been entered, the analyzer will try to connect to Wi-Fi access point. After disconnecting, the connection status may be followed on screen **<10>**.

The correct order of the messages displayed on the screen is as follows:

- **SEARCHING FOR NETWORK ...**
- **CONNECTING TO NETWORK ...**
- **OBTAINING IP ADDRESS...** (for DHCP)
- **READY**

2.14.4.2 Adding the previously configured analyzer to the database

The following procedure applies to cases when the analyzer was previously configured and has working Wi-Fi interface, and there is a need to add it to the database or to edit Wi-Fi parameters that identify the device.

To properly configure the connection, the following elements will be required **EXTERNAL IP ADDRESS** and **EXTERNAL PORT**.

Configure the analyzer in the following manner:

- Select the appropriate analyzer from the database and click **EDIT** or use **ADD** button to add it to the database.
- Use **CHANGE Wi-Fi SETTINGS** button. NOTE: Do not connect with the analyzer: in the window click **CANCEL**. The configuration will have it marked by **Wi-Fi SETTINGS (OFFLINE)**.
- Check the selection box: **EXTERNAL IP ADDRESS**
- Fill **EXTERNAL IP ADDRESS** by entering IP number of the analyzer (or IP assigned by the network administrator for the analyzer, which is available at this address) and **EXTERNAL PORT** (default 4002).
- Confirm the settings by pressing **OK**.

2 Operation of the analyzer

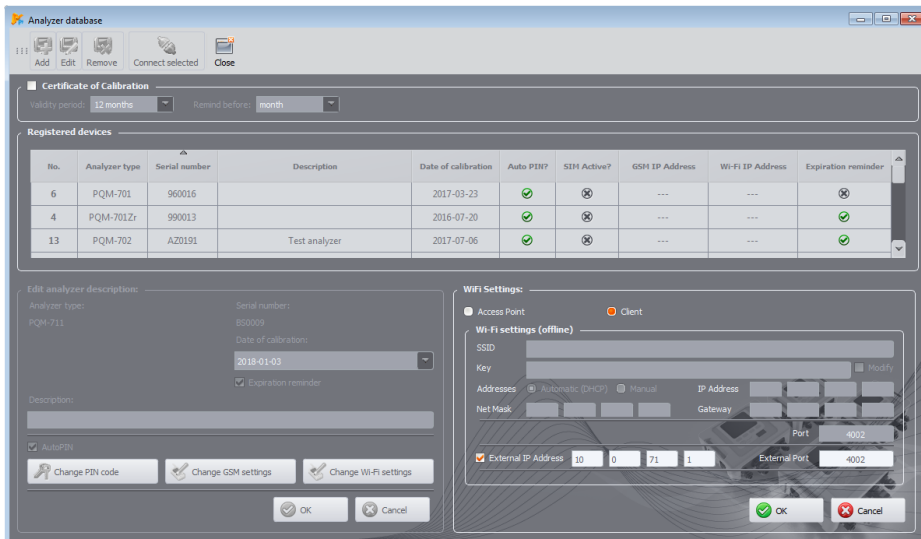

Fig. 39. Adding analyzer to database in client mode (offline)

2.14.5 Checking Wi-Fi connection

If status screen <10> shows the Wi-Fi status as **READY**, it means that a connection may be performed. The user may perform a test connection to verify the connectivity with *Sonel Analysis*:

- In the program settings, check whether the search of the analyzers via Wi-Fi is enabled: select **OPTIONS**→**PROGRAM SETTINGS**→**MEDIA SETTINGS**→**ACTIVE MEDIA**. **Wi-Fi** box should be ticked.
- The analyzer that is chosen for the connection must be entered into the Analyzer database (when the configuration was performed as described in sec. 2.14.4.1 this will be ensured).
- Disconnect the existing connection to the analyzer (USB, GSM).
- Perform a search for the analyzer, selecting any available method (e.g., by clicking **LIVE MODE**). The search list should show the analyzer with note **Wi-Fi CONNECTION**. Select the analyzer and click **SELECT**.
- After a while, the screen should display the desired window (e.g. **LIVE MODE**) and the status bar should display **CONNECTED** message. Also the analyzer screen will display **CONNECTED TO PC (Wi-Fi)** message. The connection attempt was successful.

2.14.6 Possible problems with Wi-Fi and troubleshooting

Problem: The search progress bar quickly reaches 100% and no analyzer is found.

Possible cause: It may indicate that Wi-Fi search is disabled in program settings or in the analyzer database.

Solution: From program menu select **OPTIONS**→**PROGRAM CONFIGURATION**→**MEDIA SETTINGS**→**ACTIVE MEDIA**. **Wi-Fi** box should be ticked.

Problem: The search progress bar quickly (in a few sec.) reaches 100% and no analyzer is found.

Possible causes:

- 1) The analyzer is turned off or its Wi-Fi connection is inactive/not configured.
- 2) IP address of the analyzer do not match to the address entered into the database of analyzers.
- 3) The analyzer has active Wi-Fi connection with another client or temporary network problems.

Solution:



- 1) When the analyzer is available check the Wi-Fi status on screen <10>. If the status is **DISABLED**, then select: **ANALYZER**→**ANALYZER SETTINGS** from the program menu, go to **WIRELESS CONNECTION** card and check whether **Wi-Fi COMMUNICATION ENABLED** is enabled (if not, enable it). Check Wi-Fi settings.
- 2) Check whether the correct IP address and port (only client mode) is entered to the database of analyzers.
- 3) Try to re-establish the connection.

Problem: (Applies to Access Point mode only). The network distributed by the analyzer is shown in the list of available networks, but an attempt to connect ends with error.

Possible causes:

- 1) The analyzer has been already connected to another client (screen <10> displays status **CLIENT CONNECTED**), or connection with *SoneI Analysis* is active with another computer (the screen displays message **CONNECTION WITH PC (Wi-Fi)**).
- 2) Error of network or Wi-Fi module of the analyzer.

Solution:

- 1) Disconnect the second client with the access point in the analyzer.
- 2) Restart Wi-Fi module in the analyzer by holding for at least 1.5 second the **LEFT** arrow button  or **RIGHT** arrow button,  until the display flashes. Try to connect again (NOTE: this restart is only possible when there is no active connection with *SoneI Analysis*).

Problem: Despite correct status **READY**, after the search, the analyzer is not displayed on the list. Option **Wi-Fi COMMUNICATION ENABLED** is enabled and the analyzer is properly configured in the database (including IP number).

Possible cause: TCP 4002 port is blocked – it is used for communication through a firewall installed on the PC (tablet) or in the server of internet service provider.

Solution: check whether TCP 4002 port in program settings is not blocked. If it is not, please contact your local network administrator.

Problem: During direct connection to the analyzer the transmission speed drops below 200 kB/s.

Possible causes:

- 1) The distance between the device and the Access Point/PC is too large.
- 2) Too much interference in the channel used for the transmission.

Solution:

- 1) Shorten the distance between devices to a less than 10 m.
- 2) Change the channel used for communication. When the analyzer is acting as access point then try to change the channel as described in 2.7.4. If an external Wi-Fi router is the access point, then force its operation in another channel.

Problem:

The connection with the analyzer is lost.

Possible cause:

- 1) In the window for wireless connections (Fig. 32), the Wi-Fi was disabled.
- 2) External Wi-Fi access point was disabled (only *Client* mode).
- 3) The distance between the analyzer and the PC is too large in case of a direct connection.
- 4) The distance between the analyzer and the Wi-Fi access point or between computer (tablet) and the Wi-Fi access point
- 5) Too much interference in the channel used for the transmission.

Solution:

- 1) Connect the analyzer via USB cable and enable Wi-Fi transmission in the analyzer (Fig. 32)
- 2) In *Client* mode: turn on a Wi-Fi access point and wait until the analyzer connects to it. On screen <10> Wi-Fi status is **READY**.
- 3) In *Client* mode: approach with the tablet to the analyzer and try to connect again. Preferably, the analyzer should be within sight, then screen <10> shows Wi-Fi status and signal level. Only **READY** status guarantees the ability for connection. Preferably, the indicated signal level should have at least two bars.
- 4) If possible, place the analyzer/computer (tablet) and/or Wi-Fi access point in a place where the level of Wi-Fi signal is indicated by at least two bars – both in the analyzer and the computer.
- 5) Change the channel used for communication. When the analyzer is acting as access point then try to change the channel as described in 2.7.4. If an external Wi-Fi router is the access point, then force its operation in another channel.

2.15 Notification of analyzer changed location

The analyzer, which operates a GSM modem and is within a range of GPS, may notify the user about its movements. To use this feature the user must activate **ANTI-THEFT FUNCTION** from the PC program and fill the appropriate list of emergency phone numbers for sending SMS messages with appropriate information. In this mode, the analyzer saves the position where it was acquired for the first time after turning on the recording and then sends an SMS message to the defined phone number(s), if the analyzer changes its location by more than 100 m. SMS message contains the actual coordinates of the analyzer. Also "*Sonel Analysis*" enables user to connect user to the analyzer via GSM to check the analyzer current location on the status screen (even when the analyzer is turned off - see below). When the analyzer remains for a long time at a distance greater than 100 m from its start position, then it sends SMS messages every 10 minutes detailing the current position of the analyzer (max. 10 SMS messages).

In adverse conditions for GPS reception (weak signal, signal reflections) the analyzer may send erroneous message on the location. The user is also notified of the loss/return of GPS signal by additional SMS messages.

After activating the anti-theft function, the analyzer behaves differently during switch-off mode: GSM modem and a GPS receiver are continuously active. This is also the cause of faster discharging of the battery in the absence of power supply from mains, similarly as during normal operation with the battery power supply. After discharging, the analyzer will switch-off totally and sending SMS messages will be impossible.

Note



Anti-theft feature requires the following arrangements for proper operation:

- active GSM modem with properly configured SIM card,
- at least one emergency telephone established to send SMS's.

While activating the anti-theft function, both of the above features must be checked.

2.16 Key lock

Using the PC program, the user may select an option of locking the keypad after starting the process of recording. This solution is designed to protect the analyzer against unauthorized stopping of the recording process. To unlock the buttons, the user must enter a code consisting of 3 digits:

- pressing any button will display message **ENTER CODE**, and three dashes "- - -"
- using buttons on the keyboard, the user can enter the correct unlock code: button  may be used to enter the correct unlock code: whereas button changes numbers in sequence 0, 1, 2...9, 0 at the first position, button  on the second and button  on the third.
- a three-second inactivity on the keyboard will start the verification of the entered code,
- correctly entered password is indicated by word **OK** and the lock is cancelled, whereas entering wrong password results in displaying message **INVALID CODE** and returning to the previous state (e.g. blank screen when it was blank before).

After unlocking, the keyboard automatically locks again, if the user has not pressed any button for 30 seconds.

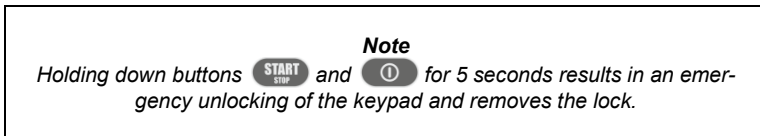

2.17 LCD sleep mode

The PC program provides an option to activate the **SLEEP MODE**. In this mode, after 10 seconds of the recording, the analyzer switches off the display. From this point, every 10 seconds the screen displays (in its upper left corner) the number of measurement point to indicate active recording. After completing recording (e.g. when the memory is full) the screen remains blank until the user presses a button.

2.18 Temperature protection





The analyzer has a temperature protection feature. When the internal temperature exceeds the specified threshold (limit operating temperature of electronic components), the analyzer stops the current operation (e.g. recording) and displays the message **MAX. OPERATING TEMP. EXCEEDED!** and then automatically switches off for 10 minutes to cool-down. The analyzer restarts when the internal temperature drops by at least 5 °C, otherwise it switches off again and the cycle is repeated.

2.19 Emergency time setting

The analyzer includes an internal button cell that supports real-time clock (RTC), regardless of the state of the Li-Ion battery. When the battery is discharged after activation of the meter, the time will be reset. To allow further work in the absence of access to a computer with *Sone! Analysis* software when it is impossible to synchronize the time with GPS time, the analyzer after starting detects the wrong time and enables its manual setting. The screen will display message **INCORRECT DATE/TIME DETECTED!** and the screen for setting the date and time will be displayed. In the next fields, the display shows the date and time in format DD.MM.YYYY, where:

- DD - day
- MM - month
- YYYY - year
- hh - hour
- mm - minutes
- ss - seconds

To set the time:

- use buttons  and  you can change the value of the selected parameter (holding down the button will automatically increase the value)
- use button  you can scroll successive parameters; the active parameter is highlighted,
- to confirm the setting, hold the  button for 2 seconds,
- to skip setting the time you can press  or wait 30 seconds without pressing any button.

3 Design and measurement methods

3.1 Voltage inputs

The voltage input block is shown in Fig. 40. Two measurement blocks are shown: on the right side of terminals main voltage circuits are presented - they are used for majority of voltage measurements. Sampling frequency of this circuit is 10.24 kHz. Three phase inputs L1/A, L2/B, L3/C and ground conductor (PE) have common reference line, which is the N (neutral) conductor.

PQM-703 PQM-711 On the left side: connection of transient module with input terminals (PQM-703 and PQM-711 only). As it is shown, all four channels are referenced to PE input. This circuit has wide bandwidth (sampling frequency: up to 10 MHz) and a greater range of measured voltages.

Fig. 40 presents that the power supply circuit of the analyzer is independent of the measuring circuit. The power adapter has a nominal input voltage range 100...690V AC and has separate terminals.

The analyzer has two voltage sub-ranges in the main circuit:

- low-voltage range, with peak voltage $\pm 450\text{V}$, is enabled at nominal voltages of mains with the range of 64V...127V and at the configurations with voltage transducers, the range is also always selected for channel U_{N-PE} ,
- high-voltage range, with peak voltage $\pm 1500\text{V}$, is enabled at nominal voltages of mains from 220V and more (without voltage transducers).

Using two voltage ranges enables the user to maintain the declared measurement accuracy, according to class A of IEC 61000-4-30 standard for all nominal voltages.

3.2 Current inputs

The analyzer has four independent current inputs with identical parameters. Each input may be used for connecting CT current probes with voltage output in standard 1 V, or several types of flexible (Rogowski) probes.

A typical situation is the use of flexible probes with built-in electronic integrator. However the described analyzer allows user to directly connect Rogowski coil to the current channel and the signal integration is performed digitally.

3.3 Digital integrator

The analyzer uses a solution of digital integration of signal provided directly from the Rogowski coil. This approach allowed us to eliminate problems related to analog integrators and the need to ensure declared accuracy for long periods and in difficult measurement environment. Analog integrators must also include protection systems to prevent output saturation when constant voltage is present at the input.

The ideal integrator has infinite gain for DC signals which descends at a rate of 20 dB/frequency decade. The phase shift is constant over the entire frequency range and is equal to 90° .

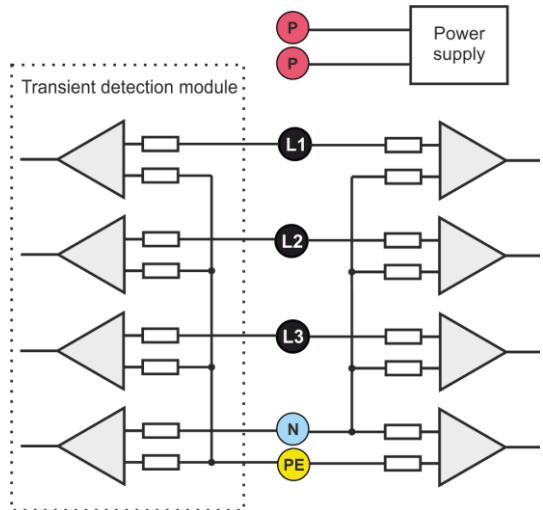

Fig. 40. Voltage inputs (with transient module) and AC adapter

Theoretically infinite gain for DC signal, when present at integrator input, causes the input saturation close to the supply voltage and prevents its further work. In practical systems, a solution is introduced to limit the gain for DC signals to some fixed value. Additionally, periodic reset of the output is performed. There are also techniques for active cancellation of DC voltage, based on its measuring and feeding it back to the input, but with the opposite sign, effectively cancelling it. In such case professionals use term "*leaky integrator*". Analog "*leaky integrator*" is simply an integrator with shunted capacitor (by resistor with high resistance). Such a system operates in the same manner as a low-pass filter with a very low cut-off frequency.

Digital implementation of the integrator ensures excellent long-term parameters - the whole procedure is performed by computing, there is no issue of component ageing, drifts etc. However, similarly to the analog version, the saturation problem may also occur and without adequate prevention it may cause the failure of digital integration. Please note that input amplifiers and analog-to-digital converters have some limited and undesirable offset, which must be removed before the integration process. The analyzer software includes a digital filter whose task is to completely remove the DC component. The filtered signal is subject to digital integration. The resulting phase characteristics are excellent and the phase shift for the most critical frequencies (50 Hz and 60 Hz) is minimal.

Ensuring the smallest phase shift between current and voltage signals is extremely important to achieve small power measurement errors. It can be shown that approximate power measurement error may be expressed in relation¹:

$$\text{Power measurement error} \approx \text{phase error (in radians)} \times \tan(\varphi) \times 100\%$$

where $\tan(\varphi)$ is the tangent of the angle between the current and its voltage fundamental components. The above formula indicates that measurement errors increase with decreasing displacement power factor, e.g. with the phase error of 0.1° and $\cos\varphi=0.5$ the error is 0.3%. Anyway, to ensure accurate power measurements, the phase coincidence of voltage and current circuits must be the highest.

3.4 Signal sampling

The signal is sampled simultaneously in all eight channels with a frequency synchronized with the frequency of power supply voltage in the reference channel. This frequency is 10.24 kHz for 50 Hz and 60 Hz.

Thus, the single period contains 204.8 samples for 50 Hz and 170.67 for 60 Hz. 16-bit analog-to-digital converter was used to ensure 64-times oversampling.

3-decibel analog attenuation has been specified for frequency approx. 20 kHz, and the amplitude error for the maximum usable frequency 3 kHz (i.e. the frequency of the 50th harmonic for 60 Hz network) is approximately 0.1 dB. The phase shift for the same frequency is less than 15° . Attenuation in the stop band is above 75 dB.

It should be noted that for the correct measurement of phase shift between the voltage harmonics in relation to current harmonics and power of these harmonics, the important factor is not absolute phase shift in relation to the basic frequency, but the phase coincidence of voltage and current circuits. Maximum phase difference error is $f = 3$ kHz, max. 15° . This error decreases with the decreasing frequency. When estimating measurement errors in power harmonics, also take into account additional error introduced by the probes and transformers.

3.5 PLL synchronization

The synchronization of sampling frequency is implemented by hardware or mixed hardware/software. After passing through the input circuits, the voltage signal is sent to a band-pass filter which is to reduce the harmonics level and pass only the voltage fundamental component. Then, the signal is routed to the Phase Locked Loop circuit as a reference signal. PLL circuit generates a frequency which is a multiple of the reference frequency required to clock the ADC.

Another issue is the input voltage range for which PLL will work properly. For this issue, 61000-

¹ Current sensing for energy metering, William Koon, Analog Devices, Inc.

4-7 standard does not provide any specific guidance or requirements. However, 61000-4-30 standard defines the input voltage range in which the metrological parameters cannot be compromised and for class A the range is: 10%...150% U_{din} . The analyzer meets the requirements listed above relating to the operation of PLL, for the rated voltage $U_{\text{nom}} \geq 64 \text{ V}$, i.e. approx. 6 V.

3.6 Frequency measurement

The signal for measuring 10-second frequency values of the network, is taken from reference voltage channel (L1/A or L2/B or L3/C depending on availability). This is the same signal that is used to synchronize the PLL. The reference signal is sent to a 2nd order band-pass filter, for which the passband was set at range of 40...70 Hz. This filter is designed for reducing the level of harmonics. Then, a square signal is formed from the filtered waveform. The signal cycles number and their duration are counted during the 10-second measuring cycle. 10-second time intervals are determined by the real time clock (every full multiple of 10-second time). The frequency is calculated as the ratio of the number of cycles counted and their duration.

3.7 Measurement of ripple control signals

The analyzer allows user to monitor two user-defined frequencies in the range up to 3000 Hz. After exceeding the threshold limit defined by the user, the analyzer records the signal level for a specified period of time (up to 120 seconds). As a standard, the analyzer measures the average values of signals for the time interval selected in settings (the main averaging period). When recording acc. to EN 50160 is selected, then additionally all 3-second average values are recorded for both frequencies - they are compared with limits specified in the standard (when the report is prepared).

3.8 Measurement of transients PQM-703 PQM-711

The option for measuring transients is available only for PQM-703 and PQM-711.

Analog-to-digital converters, typically used in power quality analyzers, have relatively low sampling frequency and are insufficient to provide required accuracy of transient recording due to the short-term nature of these disturbances and their wide frequency spectrum. For this reason, PQM-703 and PQM-711 analyzers are using a separate 4-channel A/D converter with a maximum sampling frequency of 10 MHz. This corresponds to the time between individual samples of 100 ns. In this mode it is possible to record the fastest transients, and the recording time reaches 2 ms.

Tab. 4. Summary of transient measurement modes in PQM-703 and PQM-711.

Sampling frequency	Rise time with dV/dt method	Recording time range (2000...20000 samples)
10 MHz	100 V/5 μ s	0.2...2 ms
5 MHz	100 V/10 μ s	0.4...4 ms
1 MHz	100 V/50 μ s	2...20 ms
500 kHz	100 V/100 μ s	4...40 ms
100 kHz	100 V/500 μ s	20...200 ms

To configure the transients measurement, a few options are provided for the user:

- main sampling frequency of A/D converter in the range from 100 kHz to 10 MHz,
- detection method: threshold detection - based on the set minimum transient amplitude (from 50 V to 5000 V) or a minimum slew rate (dV/dt method),
- switching recording on/off of the transient waveforms,
- recording time for timeplot in the range from 2,000 to 20,000 samples,
- pretrigger time is within the range of 10% to 90% of the recording time.

The analyzer records the timeplot of transient only in channels where events meet the criteria set by the user. After detecting a transient, the analyzer is insensitive to subsequent transients for 3 seconds. A special case is when the transient is detected only in one channel and in the time between its detection and ending of the recording process, subsequent transients occur in other channels. In this particular situation, the analyzer will record waveforms of all channels where transient events were detected. Since transients detected slightly later than the transient in the first channel, will not have exactly the same pretrigger time (recording of these channels will end up at the same time as the recording in the first channel triggered by the first event), "Sonef Analysis" software marks these events as "Transient *". Waveforms for the channel that triggered the first event, they will always appear with the other channels that triggered later event. Similarly, the opening of the graph of a later waveform (secondary transient) will also display other channels, where the disturbance occurred within the same time period. In this way, you can easily analyze the time dependence between channels.

In the event table for transients the following parameters are specified:

- **EXTREME** column includes maximum measured transient amplitude (peak-to-peak),
- **DURATION** column presents an approximate duration of the disturbance.

Measuring lines are referenced to PE input (see also Fig. 40). Transient module monitors the voltage between the inputs:

- L1/A-PE,
- L2/B-PE,
- L3/C-PE,
- N-PE.

Note

For proper measurement of transients, it is necessary to connect PE input of the analyzer to the local earthing system. It is also required for 3-wire delta and wye systems without neutral conductor.

3.8.1 Threshold method

Threshold method is chosen by selecting **THRESHOLD** (in voltage settings of the measurement point) and setting the threshold voltage in the range from 50 V to 5000 V. In this method, the analyzer detects a transient after it exceeds the pre-set amplitude in volts. Transients, whose amplitude does not exceed the set threshold will not be detected by the analyzer. In this mode, the waveform rise time is not taken into account. Both slow and fast transients will be detected, when the amplitude criterion is met.

NOTE: Threshold value entered is a transient amplitude, not the absolute voltage referred to the PE earth voltage level.

Fig. 41 shows two examples of transients and their amplitudes U_{T1} and U_{T2} . In the threshold method, the analyzer detects an event if U_{T1} or U_{T2} is greater than the threshold set by the user.

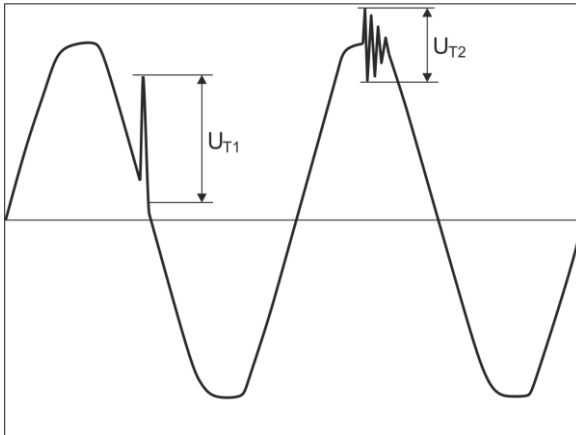

Fig. 41. Method of determining the amplitudes of transients.

3.8.2 Slew rate (dV/dt) method

Slew rate method (dV/dt) is activated by selecting **SLEW RATE** and indicating an appropriate sampling rate, which indirectly selects the voltage slew rate from several available values (see Tab. 4). In dV/dt method the device analyses the voltage waveforms in a specific time window and detects transient, if the slew rate in the window exceeds the value set by the user in settings. The absolute amplitude of the transient is not important - both transients of small and large amplitude will be detected, provided that the minimum rise requirement is met.

3.9 Current limiting function

In situations where the measured current has very low values or measuring probes were removed from the analyzer, resetting function may be useful for parameters related with the current channel. This is particularly important for parameters such as THD, which in case of noise indicate high and sometimes confusing values. When current probes are disconnected during event detection, then the analyzer almost instantly detect exceeding the threshold, which may mislead the user. To avoid such situations, limiting function is introduced for current parameters, when RMS value of the measured current is below the threshold specified by the user. To enable this function check box **CURRENT LIMIT**, located in the main settings of the measurement point, under the list of probe types. When the option is enabled, the user may specify the limit threshold as the percentage of the nominal range of selected probes, (0.00 to 0.50% of I_{nom}).

Checking whether the current value is below the specified threshold, is carried out every 10/12-period window (approx. every 200 ms). If the RMS value of the measured current in the channel is lower than the specified threshold, then the following parameters are zeroed:

- RMS current,
- current direct component (DC),
- current crest factor,
- current harmonics/interharmonics amplitudes,
- current THD and TID,
- all power values in a given channel,
- power factor and $\cos\varphi$,
- the angles between voltage and current harmonics,
- harmonics active and reactive power
- $\tan\varphi$ and K-factor.

Total values of the system are zeroed only if all current channels are below the reset threshold. Then, the following values are also reset:

- current unbalance factors and current symmetrical components.

The energy counters are frozen when the corresponding power is in “zeroed” state.

For events, some parameters are managed in a way that takes zeroing into account. The parameter value is taken into account (when detecting start and end of the event and calculating extreme and average values) only when the current value is above the threshold. Parameters managed in this way include:

- current crest factor,
- current THD and TID,
- power factor and $\cos\varphi$,
- $\tan\varphi$ and K-factor,
- current unbalance.

Zeroing is highlighted in live mode and in analysis. In order to distinguish between the actual measured value from zeroed value of reset parameter, the following rules apply:

- in live mode, the zeroed values are marked with * symbol (asterisk) next to a value (e.g. 0.000 *).
- in the data analysis, the heading of a parameter that can be zeroed is marked by adding * symbol, e.g. "I * L1 [A]" (single cells are not selected but only the header to indicate that the limiting function was applied).
- the display of the analyzer shows the zeroed values in grey.

3.10 Event detection

The analyzer offers wide range of event detection options for measured networks. "Event" is a situation where the parameter value exceeds the threshold defined by the user.

Detected events are recorded on a memory card as an entry containing:

- parameter type,
- channel, in which the event occurred,
- start and end time of the event,
- the threshold value set by the user,
- parameter extreme value measured during the event,
- parameter average value measured during the event.

Depending on the parameter type, you can set one, two or three thresholds which will be checked by the analyzer. Tab. 5 lists all parameters for which the events can be detected, including specification of threshold types. The "Waveform and RMS_{1/2}" column indicates those events which has the option to enable recording of waveforms and RMS_{1/2} charts.

Tab. 5. Types of event thresholds for each parameter.

Parameter	Inter- ruption	Dip	Swell	Mini- mum	Maxi- mum	Waveform and RMS _{1/2}
U	•	•	•		• ⁽¹⁾	•
U _{waveshape}					•	•
U _{phase_jump}					•	•
RVC					•	•
U _{DC}					•	
F				•	•	
CF U				•	•	
u ₂					•	
P _{st}					•	
P _{fl}					•	
I				•	•	•
I _{DC}					• ⁽²⁾	
CF I				•	•	
i ₂					•	
P				•	•	
Q ₁ , Q _B				•	•	
S				•	•	
D, S _N				•	•	
PF				•	•	
cosφ				•	•	
tanφ				•	•	
E _{P+} , E _{P-}					•	
E _Q					•	
E _s					•	
THD _F U					•	
U _{h2..U_{h50}}					•	
THD _F I					•	

3 Design and measurement methods

$I_{h2}..I_{h50}$	Current harmonic amplitudes ($n = 2...50$)					•	
TID _F U	voltage TID _F					•	
$U_{ih0}..U_{ih50}$	Voltage interharmonics amplitudes ($n = 0...50$)					•	
TID _F I	current TID _F					•	
$I_{ih0}..I_{ih50}$	Current interharmonics amplitudes ($n = 0...50$)					•	
K	K-Factor					•	
UR ₁ , UR ₂	Mains signalling					•	
PQM-703 PQM-711 U _t	Voltage transients					•	• ⁽³⁾

⁽¹⁾ applies to U_{N-PE} voltage.

⁽²⁾ with C-5A probes only.

⁽³⁾ recording of transient chart and waveform, no RMS_{1/2} chart.

Some of the parameters may have values that are positive or negative (+/-). For example: active power, reactive power and power factor. Since the event detection threshold may only be a positive value and to ensure proper detection for these parameters, the analyzer compares absolute values of these parameters with the set threshold.

Example

Threshold for detecting active power events was set at 10 kW. If the load has a generator nature, the active power with correct connection of probes will be a negative value. If the measured absolute value exceeds the threshold, i.e. 10 kW (e.g. -11 kW) an event will be recorded for exceeded maximum active power.

Two types of parameters: RMS voltage and RMS current may generate events, for which the user may also record waveforms.

The analyzer records the waveforms of active channels (voltage and current) at the event start and end. The user may set recording time for waveforms (from 100 ms to 1s) and the pretrigger time (from 40 ms to 960 ms). Waveforms are saved in 8-bit format with sampling frequency of 10.24 kHz.

Information about the event is recorded when the event ends. In some cases, it may happen that event is active when the recording is stopped (e.g. during a voltage dip). Information about such event is also recorded, but with the following changes:

- there is no end-time of the event,
- extreme value is calculated only for the period until the recording is stopped,
- the average value is not reported,
- only the beginning waveform is available for RMS voltage or current related events.

To eliminate repeated event detection, when the value of the parameter oscillates around the threshold value, the analyzer has a function of user-defined event detection hysteresis. It is defined as a percentage value in the following manner:

- for RMS voltage events, it is the percent of the nominal voltage range (e.g. 2% of 230 V, which is 4.6 V),

- for RMS current events, it is the percent of the nominal current range (e.g. for C-4 probes and in absence of current transducers, 2% hysteresis is $0.02 \times 1000 \text{ A} = 20 \text{ A}$,
- for events related to DC voltage and U_{N-PE} voltage, the hysteresis is calculated as a percentage of the threshold value, but not less than 50 mV (referred to input).
- for remaining parameters, the hysteresis is specified as a percent of maximum threshold (e.g. when maximum threshold for current crest factor has been set to 4.0 the hysteresis is $0.02 \times 4.0 = 0.08$).

3.10.1 Waveshape variation events

Firmware version 1.25 and later provides a new method for detecting abnormalities in the shape of the voltage waveform: waveshape variation events.

This functionality is very helpful in detecting any non-stationary disturbances in the supply network. Keep in mind that at low detection threshold, the analyzer may detect a very large number of events in a short period of time. Therefore, **HOLD TIME** parameter (expressed in seconds) is provided. After detecting an event, the analyzer blocks the detection of next events (in a given channel) for the time specified by this parameter. It may be set in the range of 1 s to 600 s.

Note

Analyzers with hardware version older than HWg, have the minimum built-in hold time of 2 seconds for waveshape variation and phase jump events (for all voltage channels) and it cannot be reduced. The hold time can be increased further in the measurement configuration if needed.

3.10.2 Phase jump events

The analyzer can detect changes in the voltage fundamental phase angle. This functionality is available for firmware version 1.25 upwards.

3.10.3 Rapid Voltage Changes (RVC) events

The analyzer can detect and record such events, only when you turn on the appropriate option in the measurement configuration. The user sets the following parameters:

- **THRESHOLD** - expressed as a percentage of the nominal voltage, setting the detection sensitivity; the smaller the threshold value, the greater sensitivity and more events of this type will be detected. A typical threshold value is 5% of U_{NOM} . Entered threshold value refers to the value ΔU_{MAX} of RVC events.
- **HYSTERESIS** is also expressed as a percentage of the nominal voltage. It must be lower than the threshold. When the hysteresis is closer to the threshold, then the range of voltage changes is narrower, which is required to state that the voltage value is stable again. Typically, the hysteresis value is set as half of the threshold.
- If the user wants to record oscillographic waveforms and $RMS_{1/2}$ graphs for voltage and currents together with RVC events, then it may be done after selecting option **LOG WAVEFORMS AND RMS 1/2**. Saved waveforms relate only to the beginning of the RVC event.

In polyphase systems, the device detects both single-phase events and polyphase events (in accordance with IEC 61000-4-30). *SoneI Analysis* software indicates polyphase events by a yellow background in the event table. It should be noted that according to the algorithm specified in IEC 61000-4-30, a polyphase event is also an event which occurred only in one phase ("polyphase" is viewed here as a "systemic" phenomenon and not as a requirement to occur in many phases simultaneously).

In the case of recording for compliance with the selected standard, which also includes the RVC measurement, RVC parameters are taken from the default settings of the selected standard.

3.11 Methods of parameter's averaging

Method of parameter averaging	
Parameter	Averaging method
RMS voltage, RMS current	RMS
DC voltage, DC current	arithmetic average
Frequency	arithmetic average
Crest factor U, I	arithmetic average
Symmetrical components U, I	RMS
Unbalance factor U, I	calculated from average values of symmetrical components
Active, Reactive, Apparent and Distortion Power	arithmetic average
Power Factor PF	calculated from the averaged power values
$\cos\phi$	arithmetic average
$\tan\phi$	calculated as the ratio of the reactive energy delta (in the related quadrant) to the active energy delta.
THD U, I	calculated as the ratio of the RMS value of the higher order harmonics to the RMS value of the fundamental component (for THD-F), or the ratio of the RMS value of higher order harmonics to the total RMS voltage (for THD-R)
TID U, I	calculated as the ratio of the RMS value of interharmonics to the RMS value of the fundamental component (for TID-F), or the ratio of the RMS value of interharmonics to the total RMS voltage (for TID-R)
Harmonic amplitudes U, I	RMS
Interharmonic amplitudes U, I	RMS
K-factor	RMS
The angles between voltage and current harmonics	arithmetic average (Cartesian method)
Active and reactive power of harmonics	arithmetic average

Note:

RMS average value is calculated according to the formula:

$$RMS = \sqrt{\frac{1}{N} \sum_{i=1}^N x_i^2}$$

The arithmetic average (AVG) is calculated according to the formula:

$$AVG = \frac{1}{N} \sum_{i=1}^N x_i \text{ and}$$

where:

- x_i is subsequent parameter value to be averaged,
- N is the number of values to be averaged.

4 Calculation formulas

4.1 One-phase network

One-phase network			
Parameter			Method of calculation
Name	Designation	Unit	
Voltage (True RMS)	U_A	V	$U_A = \sqrt{\frac{1}{M} \sum_{i=1}^M U_i^2}$ where U_i is a subsequent sample of voltage U_{A-N} $M = 2048$ for 50 Hz and 60 Hz
DC Voltage	U_{ADC}	V	$U_{ADC} = \frac{1}{M} \sum_{i=1}^M U_i$ where U_i is a subsequent sample of voltage U_{A-N} $M = 2048$ for 50 Hz and 60 Hz
Frequency	F	Hz	number of all voltage periods U_{A-N} counted during 10-sec period (clock time) divided by the total duration of full periods
Current (True RMS)	I_A	A	$I_A = \sqrt{\frac{1}{M} \sum_{i=1}^M I_i^2}$ where I_i is a subsequent sample of current I_A $M = 2048$ for 50 Hz and 60 Hz
DC Current	I_{ADC}	A	$I_{ADC} = \frac{1}{M} \sum_{i=1}^M I_i$ where I_i is a subsequent sample of current I_A $M = 2048$ for 50 Hz and 60 Hz
Active power	P	W	$P = \frac{1}{M} \sum_{i=1}^M U_i I_i$ where U_i is a subsequent sample of voltage U_{A-N} I_i is a subsequent sample of current I_A $M = 2048$ for 50 Hz and 60 Hz
Budeanu reactive power	Q_B	var	$Q_B = \sum_{h=1}^{50} U_h I_h \sin \varphi_h$ where U_h is the h -th harmonic of voltage U_{A-N} I_h is the h -th harmonic of current I_A φ_h is the h -th angle between harmonic U_h and I_h
Reactive power of fundamental component	Q_1	var	$Q_1 = U_1 I_1 \sin \varphi_1$ where U_1 is fundamental component of voltage U_{A-N} I_1 is fundamental component of current I_A φ_1 is angle between fundamental components U_1 and I_1
Apparent power	S	VA	$S = U_{ARMS} I_{ARMS}$
Apparent distortion power	S_N	VA	$S_N = \sqrt{S^2 - (U_1 I_1)^2}$ where U_1 is fundamental component of voltage U_{A-N} I_1 is fundamental component of current I_A
Budeanu distortion power	D_B	var	$D_B = \sqrt{S^2 - P^2 - Q_B^2}$
Power Factor	PF	-	$PF = \frac{P}{S}$ If $PF < 0$, then the load is of a generator type If $PF > 0$, then the load is of a receiver type

4 Calculation formulas

Displacement power factor	$\cos\varphi$ DPF	-	$\cos\varphi = DPF = \cos(\varphi_{U_1} - \varphi_{I_1})$ where φ_{U_1} is an absolute angle of the fundamental component of voltage U_{A-N} φ_{I_1} is an absolute angle of the fundamental component of current I_A
Tangent φ (4-quadrant)	$\tan\varphi_{(L+)}$	-	$\tan\varphi_{(L+)} = \frac{\Delta E_{Q(L+)}}{\Delta E_{P+}}$ where: $\Delta E_{Q(L+)}$ is the increase in reactive energy $E_{Q(L+)}$ (Budeanu/IEEE-1459) in a given averaging period, ΔE_{P+} is the increase in active power taken E_{P+} in a given averaging period
	$\tan\varphi_{(C-)}$	-	$\tan\varphi_{(C-)} = -\frac{\Delta E_{Q(C-)}}{\Delta E_{P+}}$ where: $\Delta E_{Q(C-)}$ is the increase in reactive energy $E_{Q(C-)}$ (Budeanu/IEEE-1459) in a given averaging period, ΔE_{P+} is the increase in active power taken E_{P+} in a given averaging period
	$\tan\varphi_{(L-)}$	-	$\tan\varphi_{(L-)} = \frac{\Delta E_{Q(L-)}}{\Delta E_{P+}}$ where: $\Delta E_{Q(L-)}$ is the increase in reactive energy $E_{Q(L-)}$ (Budeanu/IEEE-1459) in a given averaging period, ΔE_{P+} is the increase in active power taken E_{P+} in a given averaging period
	$\tan\varphi_{(C+)}$	-	$\tan\varphi_{(C+)} = -\frac{\Delta E_{Q(C+)}}{\Delta E_{P+}}$ where: $\Delta E_{Q(C+)}$ is the increase in reactive energy $E_{Q(C+)}$ (Budeanu/IEEE-1459) in a given averaging period, ΔE_{P+} is the increase in active power taken E_{P+} in a given averaging period
Harmonic components of voltage and current	U_{hx} I_{hx}	V A	method of harmonic subgroups according to IEC 61000-4-7 x (harmonic order) = 1..50
Total Harmonic Distortion for voltage, referred to the fundamental component	$THDU_F$	-	$THDU_F = \frac{\sqrt{\sum_{h=2}^{50} U_h^2}}{U_1} \times 100\%$ where U_h is the h -th harmonic of voltage U_{A-N} U_1 is fundamental component of voltage U_{A-N}
Total Harmonic Distortion for voltage, referred to RMS	$THDU_R$	-	$THDU_R = \frac{\sqrt{\sum_{h=2}^{50} U_h^2}}{U_{ARMS}} \times 100\%$ where U_h is the h -th harmonic of voltage U_{A-N}
Total Harmonic Distortion for current, referred to the fundamental component	$THDI_F$	-	$THDI_F = \frac{\sqrt{\sum_{h=2}^{50} I_h^2}}{I_1} \times 100\%$ where I_h is the h -th harmonic of current I_A I_1 is fundamental component of current I_A
Total Harmonic Distortion for current, referred to RMS	$THDI_R$	-	$THDI_R = \frac{\sqrt{\sum_{h=2}^{50} I_h^2}}{I_{ARMS}} \times 100\%$ where I_h is the h -th harmonic of current I_A
Total Demand Distortion	TDD	%	$TDD = \frac{\sqrt{\sum_{h=2}^{50} I_h^2}}{I_L} \times 100\%$ where I_h is the h -th harmonic of current I_A I_L is the demand current (in auto-mode I_L maximum average fundamental current from all measured current channels and whole recording period)
Interharmonic compo-	U_{hx} I_{hx}	V A	method of interharmonic subgroups acc. to IEC 61000-4-7

nents of voltage and current			x (interharmonic order) = 0..50 (sub-harmonic also includes the 5 Hz bin)
Total Interharmonic Distortion for voltage, referred to the fundamental component	$TIDU_F$	-	$TIDU_F = \frac{\sqrt{\sum_{ih=0}^{50} U_{ih}^2}}{U_1} \times 100\%$ where U_{ih} is the ih -th interharmonic of voltage U_{A-N} U_1 is fundamental component of voltage U_{A-N}
Total Interharmonic Distortion for voltage, referred to RMS	$TIDU_R$	-	$TIDU_R = \frac{\sqrt{\sum_{ih=0}^{50} U_{ih}^2}}{U_{ARMS}} \times 100\%$ where U_{ih} is the ih -th interharmonic of voltage U_{A-N}
Total Interharmonic Distortion for current, referred to the fundamental component	$TIDI_F$	-	$TIDI_F = \frac{\sqrt{\sum_{ih=0}^{50} I_{ih}^2}}{I_1} \times 100\%$ where I_{ih} is ih -th interharmonic of current I_A I_1 is fundamental component of current I_A
Total Interharmonic Distortion for current, referred to RMS	$TIDI_R$	-	$TIDI_R = \frac{\sqrt{\sum_{ih=0}^{50} I_{ih}^2}}{I_{ARMS}} \times 100\%$ where I_{ih} is ih -th interharmonic of current I_A
Voltage crest factor	CFU	-	$CFU = \frac{\max U_i }{U_{ARMS}}$ where the operator $\max U_i $ expresses the highest absolute value of voltage U_{A-N} samples $i = 2048$ for 50 Hz and 60 Hz
Current crest factor	CFI	-	$CFI = \frac{\max I_i }{I_{ARMS}}$ where the operator $\max I_i $ expresses the highest absolute value of current I_A samples $i = 2048$ for 50 Hz and 60 Hz
K-Factor	$K\text{-Factor}$	-	$K\text{Factor} = \frac{\sum_{h=1}^{50} I_h^2 h^2}{I_1^2}$ where I_h is the h -th harmonic of current I_A I_1 is fundamental component of current I_A
Harmonic active power	P_h $h=1..50$	W	$P_h = U_h I_h \cos \varphi_h$ where U_h is the h -th harmonic of voltage U_{A-N} I_h is the h -th harmonic of current I_A φ_h is the angle between harmonics U_h and I_h
Harmonic reactive power	Q_h $h=1..50$	var	$Q_h = U_h I_h \sin \varphi_h$ where U_h is the h -th harmonic of voltage U_{A-N} I_h is the h -th harmonic of current I_A φ_h is the angle between harmonics U_h and I_h
Short-term flicker	P_{st}	-	calculated according to IEC 61000-4-15
Long-term flicker	P_{lt}	-	$P_{LT} = \sqrt[3]{\frac{\sum_{i=1}^N P_{STi}^3}{N}}$ where P_{STi} is subsequent i -th indicator of short-term flicker

4 Calculation formulas

<p>Active energy (consumed and supplied)</p>	<p>E_{P+} E_{P-}</p>	<p>Wh</p>	$E_{P+} = \sum_{i=1}^M P_+(i)T(i)$ $P_+(i) = \begin{cases} P(i) & \text{for } P(\text{and}) > 0 \\ 0 & \text{for } P(i) \leq 0 \end{cases}$ $E_{P-} = \sum_{i=1}^M P_-(i)T(i)$ $P_-(i) = \begin{cases} P(i) & \text{for } P(\text{and}) < 0 \\ 0 & \text{for } P(i) \geq 0 \end{cases}$ <p>where: <i>i</i> is subsequent number of the 10/12-period measurement window <i>P(i)</i> represents active power <i>P</i> calculated in <i>i</i>-th measuring window <i>T(i)</i> represents duration of <i>i</i>-th measuring window (in hours)</p>
<p>Reactive energy (4-quadrant)</p>	<p>$E_{Q(L+)}$ $E_{Q(C-)}$ $E_{Q(L-)}$ $E_{Q(C+)}$</p>	<p>varh</p>	$E_{Q(L+)} = \sum_{i=1}^M Q_{L+}(i)T(i)$ $Q_{L+}(i) = Q(i) \text{ if } Q(i) > 0 \text{ i } P(i) > 0$ $Q_{L+}(i) = 0 \text{ in other cases}$ $E_{Q(C-)} = \sum_{i=1}^M Q_{C-}(i)T(i)$ $Q_{C-}(i) = Q(i) \text{ if } Q(i) > 0 \text{ i } P(i) < 0$ $Q_{C-}(i) = 0 \text{ in other cases}$ $E_{Q(L-)} = \sum_{i=1}^M Q_{L-}(i)T(i)$ $Q_{L-}(i) = Q(i) \text{ if } Q(i) < 0 \text{ i } P(i) < 0$ $Q_{L-}(i) = 0 \text{ in other cases}$ $E_{Q(C+)} = \sum_{i=1}^M Q_{C+}(i)T(i)$ $Q_{C+}(i) = Q(i) \text{ if } Q(i) < 0 \text{ i } P(i) > 0$ $Q_{C+}(i) = 0 \text{ in other cases}$ <p>where: <i>i</i> is subsequent number of the 10/12-period measurement window <i>Q(i)</i> represents active power (Budeanu or IEEE1459) calculated in <i>i</i>-th measuring window <i>P(i)</i> represents calculated active power in the <i>i</i>-th measuring window <i>T(i)</i> represents duration of <i>i</i>-th measuring window (in hours)</p>
<p>Apparent energy</p>	<p>E_S</p>	<p>VAh</p>	$E_S = \sum_{i=1}^M S(\text{and})T(i)$ <p>where: <i>i</i> is subsequent number of the 10/12-period measurement window, <i>S(i)</i> represents apparent power <i>S</i> calculated in <i>i</i>-th measuring window <i>T(i)</i> represents duration of <i>i</i>-th measuring window (in hours)</p>

4.2 Split-phase network

Split-phase network (parameters not mentioned are calculated as for single-phase)			
Parameter			Method of calculation
Name	Designation	Unit	
Total active power	P_{tot}	W	$P_{tot} = P_A + P_B$
Total Budeanu reactive power	Q_{Btot}	var	$Q_{Btot} = Q_{BA} + Q_{BB}$
Total reactive power of fundamental component	Q_{1tot}	var	$Q_{1tot} = Q_{1A} + Q_{1B}$
Total apparent power	S_{tot}	VA	$S_{tot} = S_A + S_B$
Total apparent distortion power	S_{Ntot}	VA	$S_{Ntot} = S_{NA} + S_{NB}$
Total Budeanu distortion power	D_{Btot}	var	$D_{Btot} = D_{BA} + D_{BB}$
Total Power Factor	PF_{tot}	-	$PF_{tot} = \frac{P_{tot}}{S_{tot}}$
Total displacement power factor	$\cos\varphi_{tot}$ DPF_{tot}	-	$\cos\varphi_{tot} = DPF_{tot} = \frac{1}{2}(\cos\varphi_A + \cos\varphi_B)$
Total tangent φ (4-quadrant)	$\tan\varphi_{tot(L+)}$	-	$\tan\varphi_{tot(L+)} = \frac{\Delta E_{Qtot(L+)}}{\Delta E_{Ptot+}}$ <p>where: $\Delta E_{Qtot(L+)}$ is the increase in total reactive energy $E_{Qtot(L+)}$ (Budeanu/IEEE-1459) in a given averaging period, ΔE_{Ptot+} is the increase in total active energy E_{Ptot+} in a given averaging period</p>
	$\tan\varphi_{tot(C-)}$	-	$\tan\varphi_{tot(C-)} = -\frac{\Delta E_{Qtot(C-)}}{\Delta E_{Ptot+}}$ <p>where: $\Delta E_{Qtot(C-)}$ is the increase in total reactive energy $E_{Qtot(C-)}$ (Budeanu/IEEE-1459) in a given averaging period, ΔE_{Ptot+} is the increase in total active energy taken E_{Ptot+} in a given averaging period</p>
	$\tan\varphi_{tot(L-)}$	-	$\tan\varphi_{tot(L-)} = \frac{\Delta E_{Qtot(L-)}}{\Delta E_{Ptot+}}$ <p>where: $\Delta E_{Qtot(L-)}$ is the increase in total reactive energy $E_{Qtot(L-)}$ (Budeanu/IEEE-1459) in a given averaging period, ΔE_{Ptot+} is the increase in total active energy taken E_{Ptot+} in a given averaging period</p>
	$\tan\varphi_{tot(C+)}$	-	$\tan\varphi_{tot(C+)} = -\frac{\Delta E_{Qtot(C+)}}{\Delta E_{Ptot+}}$ <p>where: $\Delta E_{Qtot(C+)}$ is the increase in total reactive energy $E_{Qtot(C+)}$ (Budeanu/IEEE-1459) in a given averaging period, ΔE_{Ptot+} is the increase in total active energy taken E_{Ptot+} in a given averaging period</p>
Total active energy (consumed and supplied)	E_{Ptot+} E_{Ptot-}	Wh	$E_{Ptot+} = \sum_{i=1}^M P_{tot+}(i)T(i)$ $P_{tot+}(i) = \begin{cases} P_{tot}(i) & \text{for } P_{tot}(i) > 0 \\ 0 & \text{for } P_{tot}(i) \leq 0 \end{cases}$ $E_{Ptot-} = \sum_{i=1}^M P_{tot-}(i)T(i)$

4 Calculation formulas

			<p>where: <i>i</i> is subsequent number of the 10/12-period measurement window, $P_{tot}(i)$ represents total active power P_{tot} calculated in <i>i</i>-th measuring window $T(i)$ represents duration of <i>i</i>-th measuring window (in hours)</p>
<p>Total Budeanu reactive energy (4-quadrant)</p>	$E_{Q_{tot}(L+)}$ $E_{Q_{tot}(C-)}$ $E_{Q_{tot}(L-)}$ $E_{Q_{tot}(C+)}$	<p>varh</p>	$E_{Q_{tot}(L+)} = \sum_{i=1}^M Q_{L+}(i)T(i)$ $Q_{L+}(i) = Q(i) \text{ if } Q(i) > 0 \text{ i } P(i) > 0$ $Q_{L+}(i) = 0 \text{ in other cases}$ $E_{Q_{tot}(C-)} = \sum_{i=1}^M Q_{C-}(i)T(i)$ $Q_{C-}(i) = Q(i) \text{ if } Q(i) > 0 \text{ i } P(i) < 0$ $Q_{C-}(i) = 0 \text{ in other cases}$ $E_{Q_{tot}(L-)} = \sum_{i=1}^M Q_{L-}(i)T(i)$ $Q_{L-}(i) = Q(i) \text{ if } Q(i) < 0 \text{ i } P(i) < 0$ $Q_{L-}(i) = 0 \text{ in other cases}$ $E_{Q_{tot}(C+)} = \sum_{i=1}^M Q_{C+}(i)T(i)$ $Q_{C+}(i) = Q(i) \text{ if } Q(i) < 0 \text{ i } P(i) > 0$ $Q_{C+}(i) = 0 \text{ in other cases}$ <p>where: <i>i</i> is subsequent number of the 10/12-period measurement window, $Q(i)$ represents total reactive power (Budeanu or IEEE1459) calculated in <i>i</i>-th measuring window, $P(i)$ represents total active power calculated in <i>i</i>-th measuring window, $T(i)$ represents duration of <i>i</i>-th measuring window (in hours)</p>
<p>Total apparent energy</p>	E_{Stot}	<p>VAh</p>	$E_{Stot} = \sum_{i=1}^M S_{tot}(i)T(i)$ <p>where: <i>i</i> is subsequent number of the 10/12-period measurement window $S_{tot}(i)$ represents the total apparent power S_{tot} calculated in <i>i</i>-th measuring window $T(i)$ represents duration of <i>i</i>-th measuring window (in hours)</p>

4.3 3-phase wye network with N conductor (3-phase, 4-wire)

3-phase wye network with N conductor (parameters not mentioned are calculated as for single-phase)			
Parameter			Method of calculation
Name	Designation	Unit	
Total active power	P_{tot}	W	$P_{tot} = P_A + P_B + P_C$
Total Budeanu reactive power	Q_{Btot}	var	$Q_{Btot} = Q_{BA} + Q_{BB} + Q_{BC}$
Total reactive power acc. to IEEE 1459	Q_1^+	var	$Q_1^+ = 3U_1^+ I_1^+ \sin \varphi_1^+$ where: U_1^+ is the voltage positive sequence component (of the fundamental component) I_1^+ is the current positive sequence component (of the fundamental component) φ_1^+ is the angle between components U_1^+ and I_1^+
Effective apparent power	S_e	VA	$S_e = 3U_e I_e$ where: $U_e = \sqrt{\frac{3(U_A^2 + U_B^2 + U_C^2) + U_{AB}^2 + U_{BC}^2 + U_{CA}^2}{18}}$ $I_e = \sqrt{\frac{I_A^2 + I_B^2 + I_C^2 + I_N^2}{3}}$
Effective apparent distortion power	S_{eN}	VA	$S_{eN} = \sqrt{S_e^2 + S_{e1}^2}$ where: $S_{e1} = 3U_{e1} I_{e1}$ $U_{e1} = \sqrt{\frac{3(U_{A1}^2 + U_{B1}^2 + U_{C1}^2) + U_{AB1}^2 + U_{BC1}^2 + U_{CA1}^2}{18}}$ $I_{e1} = \sqrt{\frac{I_{A1}^2 + I_{B1}^2 + I_{C1}^2 + I_{N1}^2}{3}}$
Total Budeanu distortion power	D_{Btot}	var	$D_{Btot} = D_{BA} + D_{BB} + D_{BC}$
Total Power Factor	PF_{tot}	-	$PF_{tot} = \frac{P_{tot}}{S_e}$
Total displacement power factor	$\cos \varphi_{tot}$ DPF_{tot}	-	$\cos \varphi_{tot} = DPF_{tot} = \frac{1}{3} (\cos \varphi_A + \cos \varphi_B + \cos \varphi_C)$
Total tangent φ (4-quadrant)	$\tan \varphi_{tot(L+)}$ $\tan \varphi_{tot(C-)}$ $\tan \varphi_{tot(L-)}$ $\tan \varphi_{tot(C+)}$	-	calculated as for the split-phase network
Total active energy (consumed and supplied)	E_{P+tot} E_{P-tot}	Wh	calculated as for the split-phase network
Total Budeanu reactive energy (4-quadrant)	$E_{Qtot(L+)}$ $E_{Qtot(C-)}$ $E_{Qtot(L-)}$ $E_{Qtot(C+)}$	varh	calculated as for the split-phase network

4 Calculation formulas

Total apparent energy	E_{Stot}	VAh	$E_{Stot} = \sum_{i=1}^M S_e(i)T(i)$ <p>where: i is subsequent number of the 10/12-period measurement window $S_e(i)$ represents the effective apparent power S_e, calculated in i-th measuring window $T(i)$ represents duration of i-th measuring window (in hours)</p>
RMS value of zero voltage sequence	U_0	V	$\underline{U}_0 = \frac{1}{3}(\underline{U}_{A1} + \underline{U}_{B1} + \underline{U}_{C1})$ $U_0 = \text{mag}(\underline{U}_0)$ <p>where \underline{U}_{A1}, \underline{U}_{B1}, \underline{U}_{C1} are vectors of fundamental components of phase voltages U_A, U_B, U_C Operator $\text{mag}()$ indicates vector module</p>
Voltage positive sequence component	U_1	V	$\underline{U}_1 = \frac{1}{3}(\underline{U}_{A1} + a\underline{U}_{B1} + a^2\underline{U}_{C1})$ $U_1 = \text{mag}(\underline{U}_1)$ <p>where \underline{U}_{A1}, \underline{U}_{B1}, \underline{U}_{C1} are vectors of fundamental components of phase voltages U_A, U_B, U_C Operator $\text{mag}()$ indicates vector module</p> $a = 1e^{j120^\circ} = -\frac{1}{2} + \frac{\sqrt{3}}{2}j$ $a^2 = 1e^{j240^\circ} = -\frac{1}{2} - \frac{\sqrt{3}}{2}j$
Voltage negative sequence component	U_2	V	$\underline{U}_2 = \frac{1}{3}(\underline{U}_{A1} + a^2\underline{U}_{B1} + a\underline{U}_{C1})$ $U_2 = \text{mag}(\underline{U}_2)$ <p>where \underline{U}_{A1}, \underline{U}_{B1}, \underline{U}_{C1} are vectors of fundamental components of phase voltages U_A, U_B, U_C Operator $\text{mag}()$ indicates vector module</p> $a = 1e^{j120^\circ} = -\frac{1}{2} + \frac{\sqrt{3}}{2}j$ $a^2 = 1e^{j240^\circ} = -\frac{1}{2} - \frac{\sqrt{3}}{2}j$
Voltage zero sequence unbalance ratio	u_0	%	$u_0 = \frac{U_0}{U_1} \cdot 100\%$
Voltage negative sequence unbalance ratio	u_2	%	$u_2 = \frac{U_2}{U_1} \cdot 100\%$
Current zero sequence component	I_0	A	$\underline{I}_0 = \frac{1}{3}(\underline{I}_{A1} + \underline{I}_{B1} + \underline{I}_{C1})$ $I_0 = \text{mag}(\underline{I}_0)$ <p>where \underline{I}_{A1}, \underline{I}_{B1}, \underline{I}_{C1} are vectors of fundamental components for phase currents I_A, I_B, I_C Operator $\text{mag}()$ indicates vector module</p>
Current positive sequence component	I_1	A	$\underline{I}_1 = \frac{1}{3}(\underline{I}_{A1} + a\underline{I}_{B1} + a^2\underline{I}_{C1})$ $I_1 = \text{mag}(\underline{I}_1)$ <p>where \underline{I}_{A1}, \underline{I}_{B1}, \underline{I}_{C1} are vectors of fundamental current components I_A, I_B, I_C Operator $\text{mag}()$ indicates vector module</p>

Current negative sequence component	I_2	A	$I_2 = \frac{1}{3}(I_{A1} + a^2 I_{B1} + a I_{C1})$ $I_2 = \text{mag}(I_2)$ <p>where I_{A1}, I_{B1}, I_{C1} are vectors of fundamental components for phase voltages I_A, I_B, I_C Operator $\text{mag}()$ indicates vector module</p>
Current zero sequence unbalance ratio	i_0	%	$i_0 = \frac{I_0}{I_1} \cdot 100\%$
Current negative sequence unbalance ratio	i_2	%	$i_2 = \frac{I_2}{I_1} \cdot 100\%$

4.4 3-phase wye without N conductor and delta networks

3-phase wye without N conductor and delta networks (parameters: voltage and current, DC voltage and DC current, THD and K factors, symmetrical components and unbalance factors, flicker are calculated as for 1-phase circuits; instead of the phase voltages, phase-to-phase voltages are used)			
Parameter			Method of calculation
Name	Designation	Unit	
Phase-to-phase voltage U_{CA}	U_{CA}	V	$U_{CA} = -(U_{AB} + U_{BC})$
Current I_2 (Aron measuring circuits)	I_2	A	$I_2 = -(I_1 + I_3)$
Total active power	P_{tot}	W	$P_{tot} = \frac{1}{M} \left(\sum_{i=1}^M U_{iAC} I_{iA} + \sum_{i=1}^M U_{iBC} I_{iB} \right)$ <p>where: U_{iAC} is a subsequent sample of voltage U_{A-C} U_{iBC} is a subsequent sample of voltage U_{B-C} I_{iA} is a subsequent sample of current I_A I_{iB} is a subsequent sample of current I_B $M = 2048$ for 50 Hz and 60 Hz</p>
Total apparent power	S_e	VA	$S_e = 3U_e I_e$ <p>where:</p> $U_e = \sqrt{\frac{U_{AB}^2 + U_{BC}^2 + U_{CA}^2}{9}}$ $I_e = \sqrt{\frac{I_A^2 + I_B^2 + I_C^2}{3}}$
Total reactive power (Budeanu and IEEE 1459)	Q_{tot}	var	$Q = N = \text{sign} \sqrt{S_e^2 - P^2}$ <p>where sign is equal to 1 or -1. The sign is determined basing on the angle of phase shift between standardized symmetrical components of voltages and currents</p>
Total Budeanu distortion power	D_{Btot}	var	$D_{Btot} = 0$
Effective apparent distortion power	S_{eN}	VA	$S_{eN} = \sqrt{S_e^2 + S_{e1}^2}$ <p>where: $S_{e1} = 3U_{e1} I_{e1}$</p>

4 Calculation formulas

			$U_{e1} = \sqrt{\frac{U_{AB1}^2 + U_{BC1}^2 + U_{CA1}^2}{9}}$ $I_{e1} = \sqrt{\frac{I_{A1}^2 + I_{B1}^2 + I_{C1}^2}{3}}$
Total Power Factor	PF_{tot}	-	$PF_{tot} = \frac{P_{tot}}{S_e}$
Active energy (consumed and supplied)	$\frac{E_{P_{tot+}}}{E_{P_{tot-}}}$	Wh	calculated as for the split-phase network
Total apparent energy	E_{Stot}	VAh	$E_{Stot} = \sum_{i=1}^M S_e(i)T(i)$ <p>where: <i>i</i> is subsequent number of the 10/12-period measurement window $S_e(i)$ represents the total apparent power S_e calculated in <i>i</i>-th measuring window $T(i)$ represents duration of <i>i</i>-th measuring window (in hours)</p>

5 Technical data

- Specifications are subject to change without prior notice. Recent revisions of technical documentation are available at www.sonel.com.
- Basic uncertainty is the uncertainty of a measurement instrument at reference conditions specified Tab. 6.
- Provided uncertainties apply to the analyzer without additional transformers and probes.
- Abbreviations:
 - m.v. - reference measured value,
 - U_{NOM} – nominal voltage,
 - I_{NOM} – nominal current (probes),
 - RMS – root mean square value,
 - n – harmonic order,
 - s.d. – significant digits (or significant figures) – in reference to resolution of measurement result, the value is recorded with the given number of significant digits, e.g. resolution for 230 V with 4 s.d. will be 0,1 V (notation 230,0 V); resolution for 5 A with 4 s.d. will be 0,001 A (notation 5,000 A).
 - δ_{ph} – additional uncertainty caused by the error of phase measurement between the voltage and current harmonics.

5.1 Inputs

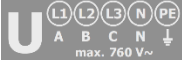
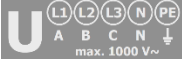
Voltage input terminals	
Number of inputs	5 (L1/A, L2/B, L3/C, N, PE (ground)) - 4 measuring channels
Maximum input voltage (referred to ground)	$U_{L-N} = 760 V_{RMS}$ $(U_{L-L MAX} = 1520 V \text{ for } U_{L-PE MAX} = 760 V)$ 40...70 Hz or DC 
Measurement category (depending on version – the rating is on the front sticker)	CAT IV 600 V / CAT III 760 V (up to 2000 m) CAT IV 300 V / CAT III 600 V / CAT II 760 V (2000 m up to 4000 m)
	$U_{L-N} = 1000 V_{RMS}$ $(U_{L-L MAX} = 2000 V \text{ for } U_{L-PE MAX} = 1000 V)$ 40...70 Hz or DC 
	CAT IV 600 V / CAT III 1000 V (up to 2000 m) CAT IV 300 V / CAT III 600 V / CAT II 1000 V (2000 m up to 4000 m)
Peak input voltage (no ADC clamping)	$\pm 1500 V$ (high voltage range) $\pm 450 V$ (low voltage range)
Analog pass band (-3dB)	20 kHz
Transducers	defined by user
Impedance of measurement inputs	10 M Ω (differential)
CMRR	>70 dB (50 Hz)

Current input terminals	
Number of inputs	4 (3 phases + neutral) not galvanically isolated
Nominal input voltage (CT probes)	1 V _{RMS}
Peak input voltage (CT probes)	±3.6 V
Nominal input voltage (flexible probes)	0.125 V _{RMS}
Peak input voltage (flexible probes)	±0.45 V
Maximum current probes input voltage referred to earth	5 V _{RMS}
Analog pass band (-3dB)	20 kHz
Input Impedance	CT probes circuit: 100 kΩ Flexible probes circuit: 12.4 kΩ
Measurement range (without transformers)	Flexible probes F-1(A)/F-2(A)/F-3(A): 1..3000 A (±10 kA peak, 50 Hz) Flexible probes F-2AHD/F-3AHD: 1..3000 A (±10 kA peak, 50 Hz) Flexible probes F-1A6/F-2A6/F-3A6: 1..6000 A (±20 kA peak, 50 Hz) Flexible probes F-1A1/F-2A1/F-3A1: 1..1500 A (±5 kA peak, 50 Hz) CT probes C-4(A): 1..1000 A CT probes C-5A: 1..1400 A CT probes C-6(A): 0.01..12 A CT probes C-7(A): 0..100 A
Transducers	defined by user
CMRR	60 dB (50 Hz)

5.2 Sampling and RTC

Sampling and RTC	
A/D converter	16-bit
Sampling rate	10.24 kHz for 50 Hz and 60 Hz Simultaneous sampling in all channels
Samples per period	204.8 for 50 Hz; 170.67 for 60 Hz
PLL synchronization	40..70 Hz
Reference channel for PLL	L1/A (default; possibility to switch to other channels)
Real-time clock	±3.5 ppm max (approx. ±9 sec./month) in the temperature range of -20°C...+55°C

5.3 Transient module **PQM-703** **PQM-711**

Transient detection module	
Number of input channels	4 (L1/A-PE, L2/B-PE, L3/C-PE, N-PE)
Maximum input voltage	760 V _{RMS} / 1000 V _{RMS} (depending on version – see rating on the front sticker)
Peak input voltage	±8000 V
Analog pass band (-3dB)	2.5 MHz
A/D converter	4-channel, 12-bit, simultaneous sampling in all channels
Sampling frequency	10 MHz, 5 MHz, 1 MHz, 500 kHz, 100 kHz (user selectable)
Waveform recording time	from 2000 to 20000 samples (from 200 µs to 200 ms, depending on settings)
Pretrigger time	from 10% to 90% of the recording time
Detection method	- amplitude (50 V...5000 V) - slew rate (dV/dt; from 100 V/500 µs to 100 V/5 µs)
Inactivity time after detection	3 s

5.4 Measured parameters - accuracy, resolution and ranges

5.4.1 Reference conditions

Tab. 6. Reference conditions.

Reference conditions	
Ambient temperature	0°C...+45°C (see also 5.4.2)
Relative Humidity	40...60%
Voltage unbalance	≤ 0.1% (applies only to 3-phase systems)
Continuous, external magnetic field	≤ 40 A/m (d.c.) ≤ 3A / m (a.c.) for 50/60 Hz frequency
DC voltage and DC current	none
Waveforms	sinusoidal
Frequency	50 Hz ±0.2% or 60 Hz ±0.2%

5.4.2 The measurement uncertainty due to ambient temperature

Basic uncertainty given in technical specifications is guaranteed for the ambient temperature range of 0°C...+45°C. Outside this range, use an additional multiplier (M), which increases the specified basic uncertainty to the actual measurement uncertainty. Fig. 42 shows a graph of M multiplier, depending on the ambient temperature within nominal operating temperatures. The multiplier has a value of 1.0 in the temperature range of 0°C...+45°C. Above +45°C and up to +55°C, the multiplier rises in linear manner up to 2.0. Below 0°C (down to -20°C), the multiplier rises in linear manner up to 1.8.

Example: Basic uncertainty for RMS voltage measurement is ±0.1% U_{nom} within ambient temp. range of 0°C...+45°C.

- at -20°C, measurement uncertainty is ±0.18% U_{nom} (multiplier 1.8)
- at -10°C, measurement uncertainty is ±0.14% U_{nom} (multiplier 1.4)
- at 0°C, measurement uncertainty is ±0.1% U_{nom} (multiplier 1.0)
- at +45°C, measurement uncertainty is ±0.1% U_{nom} (multiplier 1.0)
- at +55°C, measurement uncertainty is ±0.2% U_{nom} (multiplier 2.0)

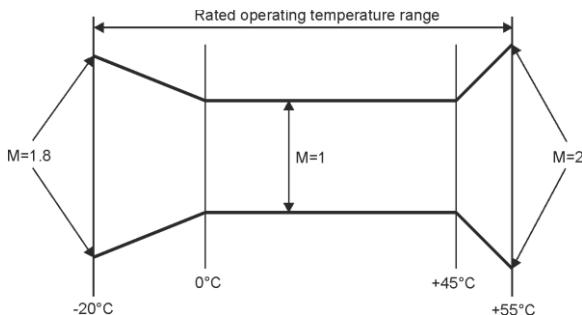

Fig. 42. Basic uncertainty multiplier M as a function of ambient temperature.

5.4.3 Voltage

Voltage	Range and conditions	Resolution	Basic uncertainty
U_{RMS} (AC+DC)	10% U_{nom} ≤ U_{RMS} ≤ 150% U_{nom} for U_{nom} ≥ 64 V	4 s.d.	±0.1% U_{nom}
Crest Factor	1..10 (1..1.65 for 690 V voltage) for U_{RMS} ≥ 10% U_{nom}	0.01	±5%

5.4.4 Current

Current	Range and conditions	Resolution	Basic uncertainty
I_{RMS} (AC+DC)	Input path without probes		
	CT line: 0..1 V (± 3.6 V max) flexible probes line: 0..125 mV (± 450 mV max)	4 s.d.	$\pm 0.1\% I_{nom}$
	Flexible probes F-1(A)/F-2(A)/F-3(A)		
	0..3000 A (± 10 kA max)	4 s.d.	Additional uncertainty See the probes user manual
	Flexible probes F-2AHD/F-3AHD		
	0..3000 A (± 10 kA max)	4 s.d.	Additional uncertainty See the probes user manual
	Flexible probes F-1A6/F-2A6/F-3A6		
	0..6000 A (± 20 kA max)	4 s.d.	Additional uncertainty See the probes user manual
	Flexible probes F-1A1/F-2A1/F-3A1		
	0..1500 A (± 5 kA max)	4 s.d.	Additional uncertainty See the probes user manual
	CT probes C-4(A)		
	0..1000 A	4 s.d.	Additional uncertainty See the probes user manual
	CT probes C-5A		
	0..1400 A	4 s.d.	Additional uncertainty See the probes user manual
CT probes C-6(A)			
0..12 A	4 s.d.	Additional uncertainty See the probes user manual	
CT probes C-7(A)			
0..100 A	4 s.d.	Additional uncertainty See the probes user manual	
Crest Factor	1..10 (1..3.6 for I_{nom}) for $I_{RMS} \geq 1\% I_{nom}$	0.01	$\pm 5\%$

5.4.5 Frequency

Frequency	Range and conditions	Resolution	Basic uncertainty
f	40..70 Hz $10\% U_{nom} \leq U_{RMS} \leq 200\% U_{nom}$	0.01 Hz (0.001 Hz on the LCD screen of the analyzer)	± 0.01 Hz

5.4.6 Harmonics

Harmonics	Range and conditions	Resolution	Basic uncertainty
Harmonic (n)	DC, 1..50, grouping: harmonics sub-groups acc. to IEC 61000-4-7		
U _{RMS} amplitude	0..20% U _{nom} (n ≥ 2) 0..150% U _{nom} (n = 1, DC)	4 s.d.	±0.05% U _{nom} if m.v.<1% U _{nom} ±5% of m.v. if m.v. ≥ 1% U _{nom} (acc. to IEC 61000-4-7 Class I)
I _{RMS} amplitude	0..20% I _{nom} (n ≥ 2) 0..150% I _{nom} (n = 1, DC)	4 s.d.	±0.15% I _{nom} if m.v.<3% I _{nom} ±5% m.v. if m.v. ≥ 3% I _{nom} (acc. to IEC 61000-4-7 Class I)
Voltage THD-R (n = 2..50)	0.0...100.0% for U _{RMS} ≥ 1% U _{nom}	0.1%	±5%
Current THD-R (n = 2..50)	0.0...100.0% for I _{RMS} ≥ 1% I _{nom}	0.1%	±5%
TDD (n = 2..50)	depending on I _L	depending on I _L	depending on I _L
K-Factor	1.0...50.0 for I _{RMS} ≥ 1% I _{nom}	0.1	±10%
Phase angle (voltage)	-180°...+180°	0.1 °	±(n × 1°)
Phase angle (current)	-180°...+180°	0.1 °	±(n × 1°)

5.4.7 Interharmonics

Interharmonics	Range and conditions	Resolution	Basic uncertainty
Interharmonic order (n)	0..50, grouping: interharmonics subgroups acc. to IEC 61000-4-7 (subharmonic additionally takes into account 5 Hz bin)		
U _{RMS} amplitude	0..20% U _{nom}	4 s.d.	±0.05% U _{nom} if m.v.<1% U _{nom} ±5% of m.v. if m.v. ≥ 1% U _{nom} (acc. to IEC 61000-4-7 Class I)
I _{RMS} amplitude	0..20% I _{nom}	4 s.d.	±0.15% I _{nom} if m.v.<3% I _{nom} ±5% m.v. if m.v. ≥ 3% I _{nom} (acc. to IEC 61000-4-7 Class I)
Voltage TID-R (n = 0..50)	0.0...100.0% for U _{RMS} ≥ 1% U _{nom}	0.1%	±5%
Current TID-R (n = 0..50)	0.0...100.0% for I _{RMS} ≥ 1% I _{nom}	0.1%	±5%

5.4.8 Harmonic Powers

Harmonic Powers	Conditions	Resolution	Basic uncertainty ⁽¹⁾
Active and reactive power of harmonics	80% U _{nom} ≤ U _{RMS} < 150% U _{nom} 5% I _{nom} ≤ I _{RMS} ≤ I _{nom}	4 s.d.	$\pm \sqrt{\Delta_{U_h}^2 + \Delta_{I_h}^2 + \Delta_{\phi_h}^2} \%$ where: δ _{U_h} – basic measurement uncertainty for voltage harmonic amplitude, δ _{I_h} – basic measurement uncertainty for current harmonic amplitude, δ _{φ_h} – basic uncertainty of the measurement of the phase between voltage and current harmonics.

(1) See section 5.4.10. Estimating measurement uncertainty values for power and energy.

5.4.9 Power and energy

Power and energy	Conditions (for power and energy $80\% U_{nom} \leq U_{RMS} < 120\% U_{nom}$)	Resolution	Basic uncertainty ⁽¹⁾
Active power Active Energy	$1\% I_{nom} \leq I_{RMS} < 5\% I_{nom}$ $\cos\varphi = 1$	4 s.d.	$\pm \sqrt{1,0^2 + \Delta_{ph}^2} \%$
	$5\% I_{nom} \leq I_{RMS} \leq I_{nom}$ $\cos\varphi = 1$		$\pm \sqrt{0,5^2 + \Delta_{ph}^2} \%$
	$2\% I_{nom} \leq I_{RMS} < 10\% I_{nom}$ $\cos\varphi = 0,5$		$\pm \sqrt{1,0^2 + \Delta_{ph}^2} \%$
	$10\% I_{nom} \leq I_{RMS} \leq I_{nom}$ $\cos\varphi = 0,5$		$\pm \sqrt{0,6^2 + \Delta_{ph}^2} \%$
Reactive power Reactive energy	$2\% I_{nom} \leq I_{RMS} < 5\% I_{nom}$ $\sin\varphi = 1$	4 s.d.	$\pm \sqrt{1,25^2 + \Delta_{ph}^2} \%$
	$5\% I_{nom} \leq I_{RMS} < I_{nom}$ $\sin\varphi = 1$		$\pm \sqrt{1,0^2 + \Delta_{ph}^2} \%$
	$5\% I_{nom} \leq I_{RMS} < 10\% I_{nom}$ $\sin\varphi = 0,5$		$\pm \sqrt{1,25^2 + \Delta_{ph}^2} \%$
	$10\% I_{nom} \leq I_{RMS} < I_{nom}$ $\sin\varphi = 0,5$		$\pm \sqrt{1,0^2 + \Delta_{ph}^2} \%$
	$10\% I_{nom} \leq I_{RMS} < I_{nom}$ $\sin\varphi = 0,25$		$\pm \sqrt{1,25^2 + \Delta_{ph}^2} \%$
Apparent power Apparent energy	$2\% I_{nom} \leq I_{RMS} < 5\% I_{nom}$	4 s.d.	$\pm 1\%$
	$5\% I_{nom} \leq I_{RMS} \leq I_{nom}$		$\pm 0,5\%$
Power factor (PF)	-1...1 $50\% U_{nom} \leq U_{RMS} < 150\% U_{nom}$ $10\% I_{nom} \leq I_{RMS} < I_{nom}$	0.01	$\pm 0,03$
Displacement power factor (cosφ/ DPF)	-1...1 $50\% U_{nom} \leq U_{RMS} < 150\% U_{nom}$ $10\% I_{nom} \leq I_{RMS} < I_{nom}$	0.01	$\pm 0,03$

(1) See section 5.4.10. Estimating measurement uncertainty values for power and energy.

5.4.10 Estimating measurement uncertainty values for power and energy

The total measurement uncertainty for power, active and reactive energy and harmonics is based on the following relation (for energy we ignore the additional uncertainty due to time measurement, as it is much smaller than other uncertainties):

$$\Delta_{P,Q} \cong \sqrt{\Delta_{Uh}^2 + \Delta_{Ih}^2 + \Delta_{ph}^2}$$

where: $\delta_{P,Q}$ – measurement uncertainty for active or reactive power,

δ_{Uh} – total measurement uncertainty of voltage harmonic amplitude (analyzer, transducers),

δ_{Ih} – total measurement uncertainty of current harmonic amplitude (analyzer, transducers),

δ_{ph} – additional uncertainty of the measurement of the phase between voltage and current harmonics.

δ_{ph} uncertainty may be calculated when the phase angle is known for the considered frequency band. Tab. 7 shows the phase error between voltage and current harmonics for analyzers (without probes and transducers).

Tab. 7. Phase error of PQM-702/703/710/711 analyzers, depending on the frequency.

	Phase difference error					
Frequency range	40..70 Hz	70..200 Hz	200..500 Hz	500 Hz..1 kHz	1..2 kHz	2..3 kHz
Error	$\leq 0,5^\circ$	$\leq 1^\circ$	$\leq 2,5^\circ$	$\leq 4^\circ$	$\leq 7^\circ$	$\leq 10^\circ$

Phase error introduced by transducers and probes may be usually found in their technical documentation. In this case, we need to estimate the resultant phase error between the voltage and

the current for a given frequency caused by all elements of the measuring circuit: current and voltage transducers, probes, and the analyzer.

The uncertainty of the harmonics active power measurements may be calculated according to the following formula:

$$\Delta_{ph} = 100 \left(1 - \frac{\cos(\varphi + \Delta\varphi)}{\cos\varphi} \right) [\%], \cos\varphi \neq 0$$

On the other hand, the uncertainty of the harmonics reactive power measurement may be calculated according to the following formula:

$$\Delta_{ph} = 100 \left(1 - \frac{\sin(\varphi - \Delta\varphi)}{\sin\varphi} \right) [\%], \sin\varphi \neq 0$$

In both formulas, φ means the actual phase shift angle between the current and voltage components, and $\Delta\varphi$ means the total phase error for a given frequency. The conclusion which can be drawn from these relationships is that power measurement uncertainty for the same phase error very clearly depends on the displacement power factor between current and voltage. It is shown in Fig. 43.

Example

Calculation of measurement uncertainty of active power fundamental component.

Conditions: $\varphi = 60^\circ$, $U_{RMS} \cong U_{nom}$, $I_{RMS} = 5\% I_{nom}$.

Basic uncertainty is $\pm \sqrt{1.0^2 + \Delta_{ph}^2}$ %.

For the frequency range of 40..70 Hz, phase error of the analyzer is less than 0.5° . After substituting equation:

$$\Delta_{ph} = 100 \left(1 - \frac{\cos(\varphi + \Delta\varphi)}{\cos\varphi} \right) = 100 \left(1 - \frac{\cos(60.5^\circ)}{\cos(60^\circ)} \right) = 1.52\%$$

therefore, the measurement uncertainty is:

$$\delta = \pm \sqrt{1.0^2 + 1.52^2} = \pm 1.82\%$$

In the same conditions, but with phase shift $\varphi = 10^\circ$:

$$\Delta_{ph} = 100 \left(1 - \frac{\cos(10.5^\circ)}{\cos(10^\circ)} \right) = 0.16\%$$

and the measurement uncertainty is:

$$\delta = \pm \sqrt{1.0^2 + 0.16^2} = \pm 1.01\%$$

These calculations do not take into account the additional errors introduced probes and transformers.

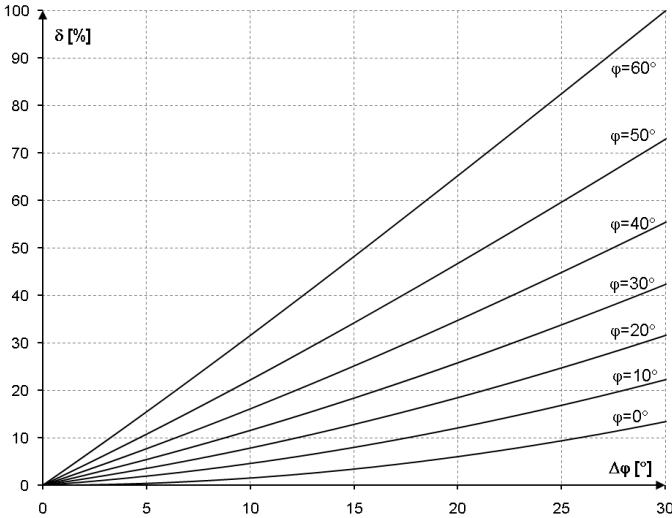

Fig. 43. Additional uncertainty due to the phase error, depending on the phase angle.

5.4.11 Flicker

Flicker	Range and conditions	Resolution	Basic uncertainty
P_{st} (10 min.) P_{It} (2 h)	0.2...10 for $U_{RMS} \geq 80\% U_{nom}$	0.01	$\pm 5\%$ within the values presented in tables of IEC 61000-4-15 standard
Class	F1 according to IEC 61000-4-15		

5.4.12 Unbalance

Unbalance (voltage and current)	Range and conditions	Resolution	Basic uncertainty
Unbalance ratio for positive, negative and zero sequence	0.0%...20.0% for $80\% U_{nom} \leq U_{RMS} < 150\% U_{nom}$	0.1%	$\pm 0.15\%$ (absolute uncertainty)

5.4.13 Mains signalling

Parameter	Range and conditions	Resolution	Basic uncertainty
Measurement method	in accordance with IEC 61000-4-30:2015		
Frequency	5.00...3000.00 Hz	0.01 Hz	not applicable
Amplitude of ripple control signal UR1, UR2	$< 1\% U_{nom}$	4 s.d.	not specified
	$1..3\% U_{nom}$		$\pm 0.15\% U_{nom}$
	$3..15\% U_{nom}$		$\pm 5\%$

5.4.14 Transients **PQM-703** **PQM-711**

Parameter	Range and conditions	Resolution	Basic uncertainty
Voltage transients	± 8000 V	4 s.d.	$\pm(5\% + 25$ V)

5.4.15 External temperature **PQM-702T**

Parameter	Description	
Measurement accuracy (ST-2 probe + analyzer)	Temperature range	Measurement uncertainty
	$-55^{\circ}\text{C} \leq T < -10^{\circ}\text{C}$	$\pm 2^{\circ}\text{C}$
	$-10^{\circ}\text{C} \leq T \leq 85^{\circ}\text{C}$	$\pm 0.5^{\circ}\text{C}$
	$85^{\circ}\text{C} < T \leq 125^{\circ}\text{C}$	$\pm 2^{\circ}\text{C}$
Resolution	0.1°C	
Communication with analyzer	digital	
Galvanic isolation of temperature input	PQM-702T - hardware revision HWf and older: <ul style="list-style-type: none"> none (temperature input is on the same potential as USB and other accessible parts) 	
	PQM-702T – hardware revision HWg and newer: <ul style="list-style-type: none"> 2500 kV DC (additional independent isolation from USB and other accessible parts) 	
Mounting to the tested object	magnetic	
Probe cable length	2.2 m	
Measurement frequency	approx. 1 measurement per second	

5.5 Event detection - dips, swells, interruptions, RVC, RMS current

U_{RMS} voltage (dips, interruptions, rises)	Range	Resolution	Basic uncertainty
U _{RMS(1/2)}	0.0%...150.0% U _{nom}	4 s.d.	$\pm 0.2\%$ U _{nom}
Duration	hh:mm:ss.ms	$\frac{1}{2}$ period	One period
Detection thresholds	Set by the user in percentage or absolute values. Event detection based on the measurement of U _{RMS(1/2)} (1-period RMS refreshed every $\frac{1}{2}$ period).		
Waveform recording	max. 1 s of recording and max. 960 ms pretrigger time, sampling: 10.24 kHz, resolution: 8-bit.		
RMS _{1/2} plot recording	max. 30 s of recording and max. 4.9 s pretrigger time sampling: half-cycle		

Rapid Voltage Change (RVC)	Range	Resolution	Basic uncertainty
U _{RMS(1/2)}	0.0%...150.0% U _{nom}	4 s.d.	$\pm 0.2\%$ U _{nom}
Duration	hh:mm:ss.ms	$\frac{1}{2}$ period	One period
Measurement method	According to IEC 61000-4-30:2015		
Detection threshold	Set by the user in percentage of U _{nom} . Event detection based on the measurement of U _{RMS(1/2)} (1-period RMS refreshed every $\frac{1}{2}$ period). Detection threshold cannot be higher than the absolute sum of dip and swell thresholds.		
Hysteresis	Set by the user in percentage of U _{nom} . Hysteresis cannot be higher than the RVC detection threshold.		
Waveform recording	max. 1 s of recording and max. 960 ms pretrigger time, sampling: 10.24 kHz, resolution: 8-bit. Recorded at the event start.		
RMS _{1/2} plot recording	max. 30 s of recording and max. 4.9 s pretrigger time sampling: half-cycle. Recorded at the event start.		

5 Technical data

I_{RMS} current (min, max)	Range	Resolution	Basic uncertainty
I _{RMS(1/2)}	0.0%...100.0% I _{nom}	4 s.d.	±0.2% I _{nom}
Duration	hh:mm:ss.ms	½ period	One period
Detection thresholds	Set by the user in percentage or absolute values. Event detection based on the measurement of I _{RMS(1/2)} (1-period RMS refreshed every ½ period).		
Waveform recording	max. 1 s of recording and max. 960 ms pretrigger time, sampling: 10.24 kHz, resolution: 8-bit.		
RMS _{1/2} plot recording	max. 30 s of recording and max. 4.9 s pretrigger time sampling: half-cycle		

5.6 Event detection - other parameters

Parameter	Range	Detection method
Frequency (min, max)	40 ... 70 Hz (percentage or absolute value)	Detection based on 10-sec. measurement (acc. to IEC 61000-4-30)
Voltage crest factor (min, max)	1.0 ... 10.0	Basing on 10/12-cycle value
Current crest factor (min, max)	1.0 ... 10.0	Basing on 10/12-cycle value
Voltage unbalance factor for negative sequence (max)	0.0 ... 20.0%	Basing on 10/12-cycle value
Current unbalance factor for negative sequence (max)	0.0 ... 20.0%	Basing on 10/12-cycle value
Short-term flicker P _{st} (max)	0..20	Basing on 10-minute value
Long-term flicker P _{lt} (max)	0..20	Basing on 2-hour value
Active power P (min, max)	Depending on the configuration	Basing on 10/12-cycle value (for consumed and supplied power)
Reactive power Q (min, max)	Depending on the configuration	Basing on 10/12-cycle value (for consumed and supplied power)
Apparent power S (min, max)	Depending on the configuration	Basing on 10/12-cycle value
Distortion power D / Apparent distortion power S _N (min, max)	Depending on the configuration	Basing on 10/12-cycle value
Power Factor PF (min, max)	0...1	Basing on 10/12-cycle value
Displacement power factor cosφ/ DPF (min, max)	0...1	Basing on 10/12-cycle value
4-quadrant tanφ (min, max)	0...10	Basing on 10/12-cycle value
Active energy E _P (max)	Depending on the configuration	Checked every 10/12 cycles (for consumed and supplied energy)
4-quadrant reactive energy E _Q (max)	Depending on the configuration	Checked every 10/12 cycles (for consumed and supplied energy)
Apparent energy E _S (max)	Depending on the configuration	Checked every 10/12 cycles
Total harmonic distortion of voltage THD-F (max)	0...100%	Basing on 10/12-cycle value
Total harmonic distortion of current THD-F (max)	0...200%	Basing on 10/12-cycle value
Voltage harmonic amplitudes (max)	0 ... 100% or absolute values	Basing on 10/12-cycle value; Independent thresholds for all harmonics in the range of 2...50
Current harmonic amplitudes (max)	0...200% or absolute values	Basing on 10/12-cycle value; Independent thresholds for all harmonics in the range of 2...50
Total interharmonics distortion of voltage TID-F (max)	0...100%	Basing on 10/12-cycle value

Total interharmonics distortion of current TID-F (max)	0...100%	Basing on 10/12-cycle value
Voltage interharmonics amplitudes (max)	0 ... 100% or absolute values	Basing on 10/12-cycle value; Independent thresholds for all interharmonics in the range of 0...50
Current interharmonics amplitudes (max)	0 ... 100% or absolute values	Basing on 10/12-cycle value; Independent thresholds for all interharmonics in the range of 0...50
K-Factor (max)	1.0..50.0	Basing on 10/12-cycle value
Mains signaling (max)	0...U _{nom}	Basing on 10/12-cycle value
PQM-703 PQM-711 Voltage transients	50...5000 V or dV/dt	Independent transient detection module, Amplitude or slew rate method
Waveshape variation (voltage only)	1.0...100% U _{nom}	Comparison of two subsequent periods of voltage waveform. See sec. 3.10.2.
Phase jumps (voltage only)	1...359° (angle degrees)	Comparison of two or three fundamental voltage phase angles calculated from subsequent periods of voltage waveform

5.6.1 Event detection hysteresis

Event detection hysteresis	Range	Calculation method
Hysteresis	0..10%	For each of the parameters calculated as a percentage of maximum threshold value (for exceptions see section 3.10)

5.7 Recording

Recorder	
Averaging time ⁽¹⁾	200 ms, 1 s, 3 s, 5 s, 10 s, 15 s, 30 s, 1 min, 3 min, 5 min, 10 min, 15 min, 30 min, 60 min, 120 min. Special Mode: ½ period (recording only U _{RMS(1/2)} and I _{RMS(1/2)}) ⁽²⁾
Averaging min / max for U _{RMS}	½ period, period, 200 ms, 1 s, 3 s, 5 s ⁽³⁾
Averaging min / max for I _{RMS}	½ period, period, 200 ms, 1 s, 3 s, 5 s ⁽³⁾
Waveforms snapshot	Option to record three periods of waveforms of active channels, after each averaging period
Recording activation mode	- manual - starting at the first detected event - scheduled (four defined time intervals)
Recording configurations	4 independent recording configurations, defined memory allocation space on the memory card, the option to allocate the whole space to a given configuration
Recording time	Depending on the configuration (see 2.8.3)
Memory	Built-in memory card 8 GB (as standard), option of extending up to 32 GB
Memory Model	Linear
Security	Key lock to prevent unauthorized access, data read-out lock with PIN

(1) Averaging times shorter than 10 sec. are in fact equal to a multiple of the mains cycle:

200 ms – 10/12 cycles, 1 s – 50/60 cycles, 3 s – 150/180 cycles, 5 s – 250/300 cycles.

(2) U_{RMS(1/2)} and I_{RMS(1/2)} are RMS values for one cycle, refreshed every half-cycle.

(3) Averaging periods min./max. 200 ms, 1 s, 3 s, 5 s are in fact equal to a multiple of the mains cycle: 200 ms – 10/12 cycles, 1 s – 50/60 cycles, 3 s – 150/180 cycles, 5 s – 250/300 cycles

5 Technical data

Recorded parameters	Mean value	Minimum value	Maximum value	Instantaneous value
RMS phase/phase-to-phase voltage (depending on the type of system) U_{RMS}	•	•	•	•
RMS phase-to-phase voltage (only 3-phase wye system with N and 2-phase system) U_{RMS}	•			
Voltage DC component	•	•	•	•
RMS current I_{RMS}	•	•	•	•
Current DC component ⁽¹⁾	•	•	•	•
Frequency f	•	•	•	•
Voltage crest factor CF U	•	•	•	•
Current crest factor CF I	•	•	•	•
Unbalance factors for negative and positive sequence, symmetrical components: negative, positive, zero (voltage) U_0, U_1, U_2, u_0, u_2	•	•	•	•
Unbalance factors for negative and positive sequence, symmetrical components: negative, positive, zero (current) I_0, I_1, I_2, i_0, i_2	•	•	•	•
Flicker severity P_{st} and P_{it}	•	•	•	•
Active power (consumed and supplied) P_+, P_-	•	•	•	•
Reactive power (consumed and supplied) $Q_{1+}, Q_{1-} / Q_{B+}, Q_{B-}$	•	•	•	•
Apparent power S	•	•	•	•
Distortion power D / Apparent distortion power S_N	•	•	•	•
Power Factor PF	•	•	•	•
Displacement power factor $\cos\phi/DPF$	•	•	•	•
$\tan\phi$ factor (4 quadrants): $\tan\phi_{(L+)}, \tan\phi_{(C-)}, \tan\phi_{(L-)}, \tan\phi_{(C+)}$	•	•	•	•
Active energy (consumed and supplied) E_{P+}, E_{P-}				•
Reactive energy (4 quadrants) $E_{Q(L+)}, E_{Q(C-)}, E_{Q(L-)}, E_{Q(C+)}$				•
Apparent energy E_s				•
Voltage total harmonic distortion (THD) THD-F	•	•	•	•
Current total harmonic distortion (THD) THD-F	•	•	•	•
Total Demand Current (TDD)	•			
Voltage harmonic amplitudes $U_{h1}...U_{h50}$	•	•	•	•
Current harmonic amplitudes $I_{h1}...I_{h50}$	•	•	•	•
Voltage total interharmonic distortion TID-R	•	•	•	•
Current total interharmonic distortion TID-F	•	•	•	•
Voltage interharmonics amplitudes $U_{ih0}...U_{ih50}$	•	•	•	•
Current interharmonics amplitudes $I_{ih0}...I_{ih50}$	•	•	•	•
K-Factor (max)	•	•	•	•
Harmonics active power (1...50) $P_{h1}...P_{h50}$	•	•	•	•
Harmonics reactive power (1...50) $Q_{h1}...Q_{h50}$	•	•	•	•
Angles between voltage and current harmonics $\phi_1... \phi_{50}$	•	•	•	•
Ripple control signals UR1, UR2	• ⁽²⁾		•	

⁽¹⁾ Only when using C-5A probes

⁽²⁾ During recording for the purposes related to compliance with EN 50160 standard, 3-second average values are also recorded.

5.8 Power supply, battery, heater

Power supply		
Input voltage range (nominal)	100...690 V AC, 40...70 Hz 140...690 V DC	
Input voltage range (including fluctuations)	90...760 V AC, 40...70 Hz 127...760 V DC	
Overvoltage category of the power supply	CAT IV 600 V CAT III 690 V CAT III 760 V (including fluctuations)	
Power consumption from mains (max)	50 VA / 20 W	
Power consumption from mains depending on configuration (typical)	PQM-702/PQM-710, no battery charging, heater disabled, GSM turned off, supply voltage 230 VAC	9 VA / 6 W
	PQM-702/PQM-710, with battery charging, heater disabled, GSM turned off, supply voltage 100...300 VAC	13 VA / 8 W
	PQM-703/PQM-711, with battery charging, heater disabled, GSM turned off, transient measurement enabled, supply voltage 100...300 VAC	15 VA / 10 W
	PQM-703/PQM-711, with battery charging, heater disabled, GSM turned on, transient measurement enabled, supply voltage 100...300 VAC	18 VA / 12 W
	PQM-703/PQM-711, with battery charging, heater disabled, GSM turned on, transient measurement enabled, supply voltage 500...690 VAC	38 VA / 13 W
	PQM-703/PQM-711, with battery charging, heater enabled and active, GSM turned on, transient measurement enabled, supply voltage 500...690 VAC	48 VA / 18 W

Rechargeable battery	
Type	Li-Ion 4.4 Ah
Operating time on battery	PQM-702, PQM-710: approx. 2 h PQM-703, PQM-711: approx. 1.5 h PQM-702, PQM-710: ≤ 5 h, when recording is active, screen is off, GSM and Wi-Fi are off, heater is off, ambient temperature approx. 20°C PQM-703, PQM-711: ≤ 5 h, when recording is active, screen is off, GSM and Wi-Fi are off, heater is off, transient module is off, ambient temperature approx. 20°C
Battery charging time (fully discharged battery)	< 8 h
Charging temperature range	-10°C ...+60°C
Current consumption from battery in analyzer off mode (mains power disconnected, does not apply to anti-theft mode)	< 1 mA

Heater	
Heater temperature threshold (activation)	+5°C
Heater power supply	from internal AC/DC adapter
Heater power	max. 5 W

5.9 Supported mains types

Types of supported mains (directly and indirectly)	
1-phase	1-phase with a neutral conductor (terminals: L1/A, N)
2-phase (split-phase)	Split phase with a neutral conductor (terminals: L1/A, L2/B, N, PE)
3-phase wye with N,	3-phase 4-wire (terminals: L1/A, L2/B, L3/C, N, PE)
3-phase delta	3-phase 3-wire delta (terminals: L1/A, L2/B, L3/C, N, PE; optionally N shorted with L3)
3-phase Aron delta	3-phase 3-wire (terminals: L1/A, L2/B, L3/C, N, PE; optionally N shorted with L3/C) with two current probes
3-phase wye without N,	3-phase 3-wire (terminals: L1/A, L2/B, L3/C, N, PE; optionally N shorted with L3/C)
3-phase wye without Aron N,	3-phase 3-wire (terminals: L1/A, L2/B, L3/C, N, PE; optionally N shorted with L3/C) with two current probes

5.10 Supported current probes

Types of supported current probes	
F-1(A)	Flexible probes (Rogowski coil), perimeter: 120 cm, measuring range 3000 A _{RMS}
F-2(A)	Flexible probes (Rogowski coil), perimeter: 80 cm, measuring range 3000 A _{RMS}
F-3(A)	Flexible probes (Rogowski coil), perimeter: 45 cm, measuring range 3000 A _{RMS}
F-2AHD	Flexible probes (Rogowski coil), perimeter: 91,5 cm, measuring range 3000 A _{RMS}
F-3AHD	Flexible probes (Rogowski coil), perimeter: 45 cm, measuring range 3000 A _{RMS}
F-1A6	Flexible probes (Rogowski coil), perimeter: 120 cm, measuring range 6000 A _{RMS}
F-2A6	Flexible probes (Rogowski coil), perimeter: 80 cm, measuring range 6000 A _{RMS}
F-3A6	Flexible probes (Rogowski coil), perimeter: 45 cm, measuring range 6000 A _{RMS}
F-1A1	Flexible probes (Rogowski coil), perimeter: 120 cm, measuring range 1500 A _{RMS}
F-2A1	Flexible probes (Rogowski coil), perimeter: 80 cm, measuring range 1500 A _{RMS}
F-3A1	Flexible probes (Rogowski coil), perimeter: 45 cm, measuring range 1500 A _{RMS}
C-4(A)	CT, AC probes, measuring range 1000 A _{RMS}
C-5A	CT, AC/DC probes with Hall sensor, measuring range 1400 A _{RMS}
C-6(A)	CT, AC probes for low currents, measuring range 12 A _{RMS}
C-7(A)	CT, AC probes, measuring range 1000 A _{RMS}

NOTE: Clamps with letter 'A' in the marking (e.g. F-3A) are clamps with automatic type detection in compatible devices. Other parameters are the same as in the case of clamps without automatic clamp type detection. Automatic clamp type detection is available in analyzers: PQM-702/703/710/711 with HWg hardware and later and with firmware 1.40 or later.

5.11 Communication

Communication	
USB	Galvanic isolated Max. transmission speed 921.6 kbit/s, mass-storage reader mode with few MB/s throughput. Compatible with USB 2.0
PQM-702 PQM-703 Wireless	Built-in 433 MHz radio module, Connection via OR-1 wireless module, Max. transmission speed: 57.6 kbit/s Range up to 5 m
PQM-710 PQM-711 Wi-Fi	Internal Wi-Fi IEEE 802.11b/g/n module, Max. effective transmission speed 300 kB/s (on distance up to 10 m) IEEE 802.11b/g IEEE 802.11 n single stream WPA/WPA2-PSK encryption supported
GSM	Built-in GSM modem with internal antenna, user-accessible SIM card slot (mini SIM 15 x 25 mm) PQM-710 up to serial no BR0999, PQM-711 up to serial no BS0999: 2G/3G modem. Supported frequency bands: <ul style="list-style-type: none"> • UMTS/HSPA: 2100 MHz (versions for European market, HWf hardware and earlier) • UMTS/HSPA: 850/1900/2100 (versions for global market, HWf hardware and earlier) • UMTS/HSPA: 850/900/1900/2100 (HWg hardware and later) • GSM/GPRS/EDGE: 850/900/1800/1900 MHz PQM-710 from serial no BR1000, PQM-711 from serial no BS1000: 2G/3G/4G modem. Supported frequency bands: <ul style="list-style-type: none"> • LTE cat. 4 FDD/TDD, 18 bands (global coverage) • UMTS/HSPA: 850/900/1900/2100 MHz • GSM/GPRS/EDGE: 850/900/1800/1900 MHz

5.12 Environmental conditions and other technical data

Environmental conditions	
Operating temperature range:	-20°C...+55°C
Storage temperature range	-30°C...+60°C
Humidity	10...90% with possible condensation
Ingress protection (according to IEC 60529)	IP65
Solar radiation	Do not use in direct sunlight conditions, use sunshade cover. Recommended covers made of plastic – metal covers may degrade GPS signal reception.
Reference conditions	Ambient temperature: 0°C...+40°C Humidity: 40...60%
Operating altitude	up to 2000 m (up to 4000 m with derated measurement category, see section 5.1)
Dimensions	200 x 180 x 77 mm (without cables)
Weight	approx. 1.6 kg
Display	color LCD TFT, 320x240 pixels, diagonal 3.5"
Data Memory	built-in memory card 8 GB (as standard), option of extending up to 32 GB

5.13 Safety and electromagnetic compatibility

Safety and EMC	
Compliance with	IEC 61010-1:2010/AMD1:2016 (Ed. 3.0) IEC 61010-2-030:2017 (Ed. 2.0)
Measurement category	CAT IV 600 V CAT III 760 V or CAT III 1000 V depending on version (see section 5.1) pollution class 2
Overvoltage category (internal AC/DC power supply)	IV 600 V III 690 V III 760 V (including fluctuations) pollution class 2
Insulation	double
Electromagnetic compatibility	IEC 61000-6-5:2015 EN 55032 (CISPR 32)
Immunity to radio frequency interferences	IEC 61000-4-3 sinusoidal modulation 80% AM, 1 kHz 80...1000 MHz, 10 V/m 1.4...2.0 GHz, 3 V/m 2.0...2.7 GHz, 1 V/m
Immunity to electrostatic discharge	IEC 61000-4-2 Air discharge: 8 kV Contact discharge: 4 kV
Immunity to conducted disturbances, induced by radio-frequency fields	IEC 61000-4-6 sinusoidal modulation 80% AM, 1 kHz 0.15...80 MHz, 10 V
Immunity to series of fast transients/bursts	IEC 61000-4-4 Amplitude 2 kV, 5 kHz
Immunity to surges	IEC 61000-4-5 Amplitude 2 kV (L-L), 4 kV (L-PE)
Emission of radiated RF disturbances	IEC 61000-6-3 class A: 30...230 MHz, 40 dB(μ V/m) at 10 m 230...1000 MHz, 47 dB(μ V/m) at 10 m
Emission of conducted disturbances	IEC 61000-6-3 Levels for a quasi-peak detector: 0.15 kHz...0.5 MHz: 66 dB μ V...56 dB μ V 0.5 MHz...5 MHz: 56 dB μ V 5 MHz...30 MHz: 60 dB μ V

EN 55032 Compliance statement:

PQM-702, PQM-703, PQM-710 and PQM-711 are class A products. In a domestic environment these products may cause radio interference in which case the user may be required to take adequate measures (e.g. increasing distance between affected devices).

Note:

PQM-710 **PQM-711** SONEL S.A. hereby declares that the radio device type PQM-710/711 complies with Directive 2014/53/EU. The full text of the EU Declaration of Conformity is available at the following website address: <https://sonel.pl/en/download/declaration-of-conformity/>

5.14 Standards

Standards	
Product standard	IEC 62586-1:2017 (Ed. 2.0) IEC 62586-2:2017/COR1:2018 (Ed. 2.0) Product classification: PQI-A-PO (measurement class A acc. to IEC 61000-4-30, Portable , Outdoor , EMC environment G)
Measurement methods	IEC 61000-4-30:2015/COR1:2016 (Ed. 3.0) class A
Measurement accuracy	IEC 61000-4-30:2015/COR1:2016 (Ed. 3.0) class A
Power quality	EN 50160:2010
Flicker	IEC 61000-4-15:2010/COR1:2012 (Ed. 2.0)
Harmonics	IEC 61000-4-7:2002/AMD1:2008 (Ed. 2.0)
Safety	IEC 61010-1:2010/AMD1:2016 (Ed. 3.0) IEC 61010-2-030:2017 (Ed. 2.0)
EMC	EN 55032:2015 IEC 61000-6-5:2015
Quality standard	design, construction and manufacturing are ISO 9001 compliant

5.14.1 Compliance with standards

The analyzer is designed to meet the requirements of the following standards.

Product standards:

- IEC 62586-1:2017 – Power quality measurement in power supply systems - Part 1: Power quality instruments (PQI).
- IEC 62586-2:2017 – Power quality measurement in power supply systems - Part 2: Functional tests and uncertainty requirements.

Standards for measuring network parameters:

- IEC 61000-4-30:2015/COR1:2016 (Ed. 3.0) – Electromagnetic compatibility (EMC) - Testing and measurement techniques - Power quality measurement methods.
- IEC 61000-4-7:2002/AMD1:2008 (Ed. 2.0) – Electromagnetic compatibility (EMC) – Testing and Measurement Techniques - General Guide on Harmonics and Interharmonics Measurements and Instrumentation for Power Supply Systems and Equipment Connected to them.
- IEC 61000-4-15:2010/COR1:2012 (Ed. 2.0) – Electromagnetic compatibility (EMC) – Testing and Measurement Techniques - Flickermeter - Functional and Design Specifications.
- EN 50160:2010 – Voltage characteristics of electricity supplied by public distribution networks.

Safety standards:

- IEC 61010-1:2010/AMD1:2016 (Ed. 3.0) – Safety requirements for electrical equipment for measurement control and laboratory use. Part 1: General requirements.
- IEC 61010-2-030:2017 (Ed. 2.0) – Safety requirements for electrical equipment for measurement, control, and laboratory use – Part 2-030: Particular requirements for equipment having testing or measuring circuits

Standards for electromagnetic compatibility:

- EN 55032:2015 – Electromagnetic compatibility of multimedia equipment - Emission Requirements.
- IEC 61000-6-5:2015 – Electromagnetic compatibility (EMC) - Part 6-5: Generic standards - Immunity for equipment used in power station and substation environment.

The device meets all the requirements of Class A as defined in IEC 61000-4-30. The summary of the requirements is presented in the table below.

Tab. 8. Summary of selected parameters in terms of their compliance with the standards

Aggregation of measurements at different intervals	IEC 61000-4-30 Class A: <ul style="list-style-type: none"> • Basic measurement time for parameters (voltage, current, harmonics, unbalance) is a 10-cycle interval for 50 Hz power supply system and 12-cycle interval for 60 Hz system, • Interval of 3 s (150 cycles for the nominal frequency of 50 Hz and 180 cycles for 60 Hz), • Interval of 10 minutes, • Interval of 2 h (basing on 12 intervals of 10 min.) • Synchronization of aggregation intervals
Real-time clock (RTC) uncertainty	IEC 61000-4-30 Class A: <ul style="list-style-type: none"> • Clock synchronization to GPS time using the built-in GPS receiver with internal or external antenna, • Built-in real time clock, which is set from "<i>Sonet Analysis</i>", • RTC accuracy after GPS signal loss - better than ± 0.3 s/day
Frequency	Compliant with IEC 61000-4-30 Class A of the measurement method and uncertainty
Power supply voltage	Compliant with IEC 61000-4-30 Class A of the measurement method and uncertainty
Voltage fluctuations (flicker)	The measurement method and uncertainty meets the requirements of IEC 61000-4-15 standard, class F1
Dips, interruptions and surges of supply voltage	Compliant with IEC 61000-4-30 Class A of the measurement method and uncertainty
Supply voltage unbalance	Compliant with IEC 61000-4-30 Class A of the measurement method and uncertainty
Voltage and current harmonics	Compliant with IEC 61000-4-30 Class A of the measurement method and uncertainty (IEC 61000-4-7 Class I)
Voltage and current inter-harmonics	Compliant with IEC 61000-4-30 Class A of the measurement method and uncertainty (IEC 61000-4-7 Class I)
Mains signalling voltage on the supply voltage	Compliant with IEC 61000-4-30 Class A of the measurement method and uncertainty
Rapid Voltage Changes (RVC)	Compliant with IEC 61000-4-30 Class A of the measurement method and uncertainty
Magnitude of current	Compliant with IEC 61000-4-30 Class A of the measurement method and uncertainty

5.14.2 Product specification according to IEC 62586

Product specification		PQI-A-PO (measurement class A acc. to IEC 61000-4-30, Portable, Outdoor, EMC environment G)		
Symbol	Function	Class acc. to IEC 61000-4-30	Range	Additional information
f	power frequency	A	40...70 Hz	
U	magnitude of the supply voltage	A	10%...150% U_{din}	6,4...760 V $U_{din} \leq 506$ V
P_{ST}, P_{LT}	flicker	A	P_{ST} 0.2...10	class F1
U_{dip}, U_{swl}	supply voltage dips and swells	A	–	
U_{int}	supply voltage interruption	A	–	
u_0, u_2	supply voltage unbalance	A	0.0%...20.0%	
U_h	voltage harmonics	A	200% of class 3 compatibility levels from IEC 61000-2-4	
U_{ih}	voltage interharmonics	A	200% of class 3 compatibility levels from IEC 61000-2-4	
MSV	mains signalling voltage	A	0...15% U_{din}	$U_{din} \leq 690$ V
<i>Under/over</i>	under/over deviation	<i>not applicable</i>	–	
RVC	rapid voltage change	A	–	
I	magnitude of current	A	0%...150% I_{nom}	
i_0, i_2	current unbalance	A	0,0%...20,0%	
I_h	current harmonics	A	200% of class 3 compatibility levels from IEC 61000-2-4	
I_{ih}	current interharmonics	A	200% of class 3 compatibility levels from IEC 61000-2-4	

Notes: U_{din} is declared input voltage of the analyzer ie. taking into account the transducers. If transducers are not used then $U_{nom} = U_{din}$. If transducers are used then $U_{nom} = k \times U_{din}$, where k is the transducer ratio, eg. for a transducer 15 kV:100 V $\Rightarrow k=150$, $U_{nom}=15$ kV, $U_{din}=100$ V.

6 **Cleaning and maintenance**

Note

Use only the maintenance methods specified by the manufacturer in this manual.

The casing of the analyzer may be cleaned with a soft, damp cloth using all-purpose detergents. Do not use any solvents or cleaning agents which might scratch the casing (powders, pastes, etc.). Cables should be cleaned with water and detergents, and then dried. The analyzer electronic system does not require maintenance.

7 **Storage**

In the case of storage of the device, the following recommendations must be observed:

- Disconnect all the test leads from the meter.
- Clean the meter and all its accessories thoroughly.
- In order to prevent a total discharge of the accumulators in the case of a prolonged storage, charge them from time to time.

8 **Dismantling and utilization**

Worn-out electric and electronic equipment should be gathered selectively, i.e. it must not be placed with waste of another kind.





Worn-out electronic equipment should be sent to a collection point in accordance with the law of waste electrical and electronic equipment.

Before the equipment is sent to a collection point, do not dismantle any elements.

Observe local regulations concerning disposal of packages, waste batteries and accumulators.

9 Optional accessories

- The parameters apply to clamps currently on offer. For the parameters of all clamps in a given series, please refer to the user manual of the respective accessory.
- The full list of accessories can be found on the manufacturer's website.

				
	C-4A	C-5A	C-6A	C-7A
	WACEGC4AOKR	WACEGC5AOKR	WACEGC6AOKR	WACEGC7AOKR
Rated current	1000 A AC	1000 A AC 1400 A DC	12 A AC	100 A AC
Frequency	30 Hz...5 kHz	DC...5 kHz	40 Hz...10 kHz	40 Hz...1 kHz
Max. diameter of measured conductor	52 mm	39 mm	20 mm	24 mm
Minimum accuracy	≤0,5%	≤1.5%	≤1%	0,5%
Battery power	—	√	—	—
Lead length	2.2 m	2.2 m	2.2 m	3 m
Measurement category	III 600 V IV 300 V	IV 300 V	III 600 V IV 300 V	III 300 V
Ingress protection	IP40			

					
	F-1A1 / F-1A / F-1A6	F-2A1 / F-2A / F-2A6	F-3A1 / F-3A / F-3A6	F-2AHD	F-3AHD
	WACEGF1A1OKR WACEGF1AOKR WACEGF1A6OKR	WACEGF2A1OKR WACEGF2AOKR WACEGF2A6OKR	WACEGF3A1OKR WACEGF3AOKR WACEGF3A6OKR	WACEGF2AHDOKR	WACEGF3AHDOKR
Rated current	1500 / 3000 / 6000 A AC	1500 / 3000 / 6000 A AC	1500 / 3000 / 6000 A AC	3000 A AC	
Frequency	40 Hz...10 kHz			10 Hz...20 kHz	
Max. diameter of measured conductor	380 mm	250 mm	140 mm	290 mm	145 mm
Minimum accuracy	0.5%			0.5%	
Battery power	—			—	
Lead length	2.5 m			2.5 m	
Measurement category	III 1000 V IV 600 V			III 1000 V IV 600 V	
Ingress protection	IP67			IP65	

External active GPS antenna

- frequency: 1575.42 GHz
- polarization: RHCP
- LNA gain: 26 dB (3 V)
- VSWR: <1.2:1
- dimensions (without cable): 14.0 × 34.2 × 38.2 mm
- operating temperature: -40°C...+85°C
- protection rating acc. to IEC 60529: IP67
- cable length: 10 m
- current consumption: 15...25 mA
- mounting: magnetic, any surface



Fig. 44. External GPS antenna.

10 Manufacturer

The manufacturer of the device and provider of guarantee and post-guarantee services:

SONEL S.A.
Wokulskiego 11
58-100 Świdnica
Poland
tel. +48 74 884 10 53 (Customer Service)
e-mail: customerservice@sonel.com
web page: www.sonel.com

Note

Service repairs must be performed only by the manufacturer.

Note

PQM-710 PQM-711 SONEL S.A. does not provide a warranty for the included tablet or its accessories. In case of discrepancies in the operation of the tablet, please contact the tablet manufacturer directly to file a complaint. Current contact details can be obtained from the manufacturer's website.

NOTES

NOTES

NOTES



SONEL S.A.

Wokulskiego 11
58-100 Świdnica
Poland

Customer Service

tel. +48 74 884 10 53
e-mail: customerservice@sonel.com

www.sonel.com