



OPERATION MANUAL

WIRE TRACER

LKZ-700



OPERATING MANUAL

WIRE TRACER

LKZ-700



Wire tracer LKZ-700 is intended to locate electrical cabling embedded in different materials (concrete, bricks, timber) in buildings. It can be also used to detect cabling located underground. The cables can be detected regardless whether they are live or not.

Tracer's main features:

- Detection of cables in ceilings, walls and floors
- Detections of breaks in cabling, switches and fuses
- Locating routes of shorted circuits
- Locating faults in grounding conductors in three phase installations
- Detection of constrictions in cable ducts
- Tracing underground cables up to 2m below the surface (in the power mode)
- Tracing conductive water and heating pipelines
- Identification of cables in an installation

TABLE OF CONTENTS

1	INTRODUCTION	5
2	SAFETY	6
3	PREPARING THE DEVICE FOR WORK	8
4	EQUIPMENT DESCRIPTION.....	9
4.1	TRANSMITTER LKN-700	9
4.1.1	Front Panel.....	9
4.1.2	Audible signals	10
4.2	RECEIVER LKO-700	11
4.2.1	Front Panel.....	11
4.2.2	Audible signals	12
4.3	LEADS.....	13
5	WORKING PRINCIPLES	13
5.1	GENERAL INFORMATION.....	13
5.2	TRANSMITTER.....	13
5.3	RECEIVER	13
5.4	CLOSED-CIRCUIT MEASUREMENTS.....	14
5.5	OPEN-CIRCUIT MEASUREMENTS.....	15
6	WORK MODES	16
6.1	GENERAL INFORMATION.....	16
6.2	“M” MODE.....	16
6.3	„E” MODE.....	17
6.4	„M+E” MODE.....	17
6.5	“AUTO” MODE	17
6.6	„E” (“POWER”) MODE	18
6.7	AUDIBLE SIGNALIZATION OF FIELD INTENSITY	18
7	MEASUREMENTS.....	18
7.1	ZOOM FUNCTION	19
7.2	DETECTION OF CABLES IN CEILINGS, WALLS AND FLOORS.....	20
7.2.1	Live Cables	20
7.2.2	Dead Cables	21
7.2.3	Using „M+E” and “Power” „E” modes	22
7.3	LOCATING BREAKS IN CABLES	23
7.4	TRACING OF THE ENTIRE BUILDING INSTALLATION.....	23
7.5	LOCATING POWER POINTS AND SWITCHES IN BUILDINGS.....	24
7.6	IDENTIFICATION OF FUSES ON THE DISTRIBUTION BOARD.....	24

7.7	LOCATING SHORT CIRCUITS BETWEEN LEADS	25
7.8	LOCATING UNDERGROUND DEAD CABLES (NOT IN USE).....	28
7.9	TRACING SHIELDED CABLES	32
7.10	TRACING CABLES IN METAL DUCTS	34
7.11	TRACING WATER PIPES AND HEATING PIPELINES	34
7.11.1	<i>Closed Circuit</i>	34
7.11.2	<i>Open Circuit</i>	35
7.12	INVESTIGATING CHANNELS AND HOLES ROUTINGS	36
8	TROUBLE SHOOTING	37
9	POWER SUPPLY	37
9.1	BATTERIES	37
9.1.1	<i>Replacement of the Battery Pack</i>	37
9.1.2	<i>Charging the Battery Pack</i>	37
9.1.3	<i>General principles of using nickel metal hydride (Ni-MH) accumulators</i>	39
9.2	REPLACEMENT OF BATTERIES IN THE RECEIVER	40
10	CLEANING AND MAINTENANCE.....	41
11	STORAGE.....	41
12	DECOMMISSIONING AND RECYCLING.....	41
13	APPENDICES.....	42
13.1	TECHNICAL SPECIFICATIONS	42
13.2	STANDARD ACCESSORIES.....	42
13.3	OPTIONAL ACCESSORIES	43
13.4	THE MANUFACTURER	43

1 Introduction

Thank you for choosing our wire tracer. LKZ-700 is a state of the art, high quality device that is simple and safe to operate. Nevertheless familiarization with this manual will help you avoid errors and possible problems that might occur while using the device.

This instruction manual uses three types of warnings. They are framed texts describing possible threats for a user and for the equipment. Texts that start with a word "**WARNING:**" describe situations that can become hazardous if the instructions are not followed. The word "**NOTE!**" at the beginning of the framed text signals a situation where non-adherence to the instruction can damage the equipment. Other possible problems are signalled by a "**Note:**" flag.

WARNING:

Before using the device read carefully this manual, follow all occupational health and safety rules and manufacturer's recommendations.

WARNING:

LKZ-700 is intended for searching and locating power lines in walls, in the ground etc. Using the device for purposes other then described in this manual can cause an injury to the operator and/or can damage the device.

WARNING:

LKZ-700 may be used only by qualified personnel who are certified to work with electrical installations. Operating the instrument by a person who is not qualified, can result in a hazardous situation and/or can cause damage to the device.

2 Safety

WARNING:

Using a device that has damaged housing or with leads that have damaged insulation can be a source of a safety hazard.

To ensure proper use and correctness of obtained results adhere to the following recommendations:

- Before starting to use the device, you have to become thoroughly familiar with this manual.
- The device should be operated only by persons holding appropriate qualifications and who attended appropriate occupational health and safety training.
- It is not acceptable to:
 - use the device that is damaged in any way and is partially or fully in-operative
 - use leads with damaged insulation
 - use the meter stored in inappropriate conditions (e.g. high humidity) for a prolonged period of time
- Before connecting to the tested network, select correct parameters for the device.
- Repairs can be performed by authorised service agents only.

Additionally remember that

- Flashing icon  in the transmitter means too low power supply voltage and signals a need to recharge the batteries.

NOTE!

The transmitter is designed to work with a rated voltage of 230/400V. Connecting the device to a voltage that exceeds 500VAC can damage the instrument.

WARNING:

The instrument must not be used with installations or equipment situated in dangerous environments, e.g. where fire or explosion hazards exists.

WARNING:

Disconnecting the protective cable can endanger lives of the user as well as other persons present during the measurements. Wherever it is possible disconnect the mains voltage and the phase cable(s) first. You should be particularly careful when disconnecting the protective wire or the protective wire earthing from the installation that has to be live. You have to ensure that there are no other persons in the danger zone. After completing the task you must restore the PE or N wire connection.

3 Preparing the Device for Work

Before you start locating cables:

- Ensure that the transmitter's and receiver's batteries are charged sufficiently to carry out the measurements.
- Check if the transmitter's housing and leads' insulation are not damaged

WARNING:
Using leads with damaged insulation can cause electrocution.

WARNING:
You must not use the device with fully or partially open battery cover.
You must not power the device from sources other than those specified in this instruction.

WARNING:
You must not leave one lead disconnected from the device while the other one is connected to the tested installation.
You must not leave the device connected to the tested installation without supervision.

WARNING:
Do not use a device that was stored for a prolonged period of time in unsuitable (e.g. humid) conditions.

4 Equipment Description

4.1 Transmitter LKN-700

4.1.1 Front Panel

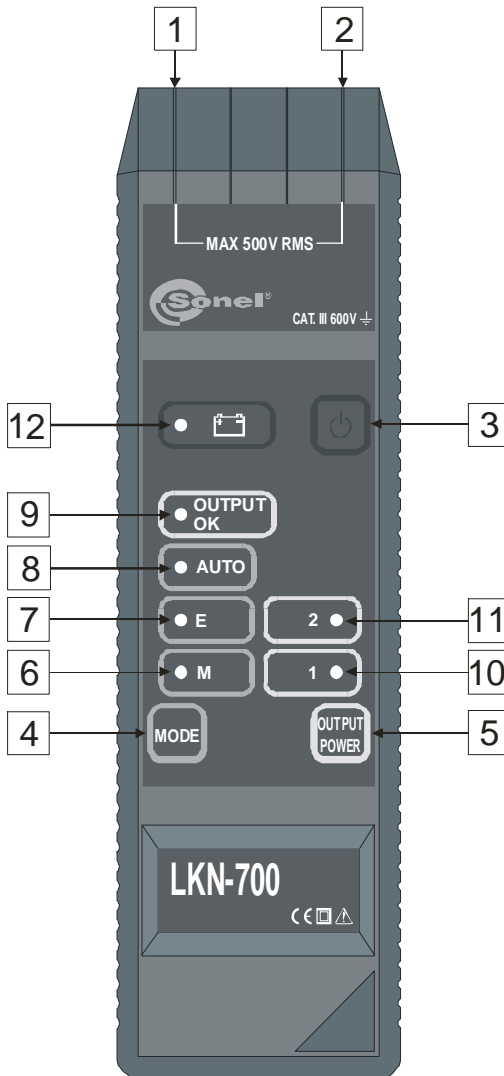





Fig.1. Detector's transmitter (front panel)

NOTE!

The transmitter is designed to work with the rated voltage of 230/400V. Connecting the device to voltage that exceeds 500VAC can damage the instrument.

- 1 Jack plug**
A socket for connecting the tested installation.
- 2 Jack plug**
A socket for connecting the tested installation.
- 3 Button** 
On/Off switch.
- 4 Button** 
Mode switch.
- 5 Button** 
Output power setting.
- 6 LED M**
Signals that the device entered a current (“M”) mode.
- 7 LED E**
Signals that the device entered a voltage (“E”) mode.
LEDs **6** and **7** glowing simultaneously signal that the device is in a mixed (current-voltage „M+E”) mode.
- 8 LED AUTO**
Signals that the device is in an auto mode.
- 9 LED OUTPUT OK**
Signals that the device is working OK.
- 10 LED 1**
Signals that the low output power was selected.
- 11 LED 2**
Signals that the medium output power was selected.
LEDs **10** and **11** glowing simultaneously signal that the high output power was selected.
- 12 LED** 
Battery discharged.

4.1.2 Audible signals

Warning signals:

Short (ca 0.25 sec.) audible signal repeated every 1s

- Detected voltage in the tested installation (in voltage mode „E”)

- The transmitter is unable to generate sufficient current in the current „M” or current-voltage “M+E” mode

Confirmation and other signals:

Short audible signal

- Button press confirmation
- Change of broadcasting mode in the **AUTO** mode

Long audible signal (ca 0.5s)

- Self test completed after the transmitter was switched on (signalling of irregularities – see section 8.2)
- Button disabled

4.2 Receiver LKO-700

4.2.1 Front Panel

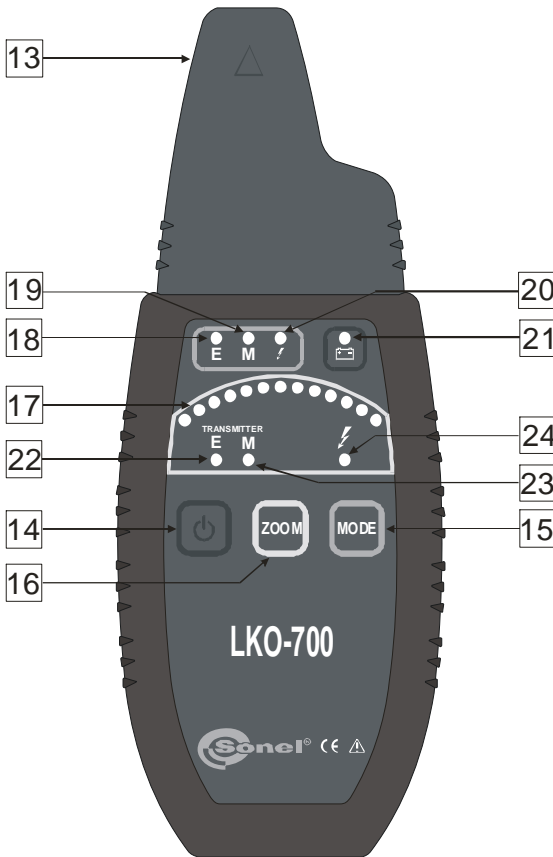







Fig.2. Detector's receiver (front panel)

- 13 Antenna**
Houses device's magnetic and electric field detectors
- 14 Button** 
ON/OFF switch.
- 15 Button** 
Alternating between channels: current or voltage.
- 16 Button** 
Turning the precision positioning function on (amplified visualization of changes in magnetic or electric field).
- 17 LED gauge**
Magnetic/electric field indicator.
- 18 LED E**
Signals that the device is using a voltage channel.
- 19 LED M**
Signals that the device is using a current channel.
- 20 LED** 
Signals the neon indicator being activated.
- 21 LED** 
Battery discharged.
- 22 LED TRANSMITTER E**
Signals detection of the transmitter's voltage mode.
- 23 LED TRANSMITTER M**
Signals detection of the transmitter's current mode.
LEDs **22** and **23** glowing simultaneously signal detection of transmitter's mixed (current-voltage „**M+E**“) mode.
- 24 LED** 
Signals detection of an electric field 50/60Hz that originates from phase cables (neon indicator).

4.2.2 Audible signals

Confirmations and others:

Short audible signal

- Button pressed
- Change in sensitivity sub-range in the ZOOM mode

Long audible signal (ca 0.5s)

- Completion of self test after turning the transmitter on

Modular audible signal

- With frequency directly proportional to signal level

4.3 Leads

Crocodile clips and probes provided with the leads can be placed on cable terminators.

WARNING:

Connecting to the device leads that are inadequately insulated or feature unsuitable plugs can be dangerous for the operator.

5 Working Principles

5.1 General Information

LKZ-700 system consists of two components: transmitter and receiver. The transmitter connected to the circuit being traced generates magnetic („M” mode) or electric („E” mode) field around the circuit.

Magnetic field is created as a result of a suitably modulated current flowing through the tested (closed) circuit.

Electric field is created as a result of a suitably modulated voltage being applied to the tested (open) circuit (the intensity and the shape of the field depends on the environment in which it is created).

The transmitter placed alongside the tested circuit detects the modulated field and notifies the user. Mapping of the circuit (cable) route or its defects is possible through observation of the detected signal intensity level.

5.2 Transmitter

Electromagnetic signals broadcast by the transmitter are appropriately modulated. Therefore it is possible to differentiate between them and other signals that may be present in the tested circuit or its immediate vicinity. The signal has also different signatures for different broadcast modes to enable the receiver their remote interpretation. Broadcast modes can be switched sequentially from one to another by pressing the **4** MODE button. Pressing the button activates an appropriate LED **6**, **7**, **8** (different work modes are described in section 6). The **5** OUTPUT RESERVE button can be also used to set (also sequentially) one of three power levels:

- low – LED **10** 1 on
- middle – LED **11** 2 on
- high – LEDs **10** 1 and **11** 2 on

Blinking LED **9** OUTPUT OK informs that a test signal is being sent by the transmitter. LED remaining switched off signals that the broadcast mode has been incorrectly selected for conditions in the tested circuit.

5.3 Receiver

Receiver's antenna **13** hides two sensors: an electric field detector and a magnetic field detector. The electric field detector has an aerial shaped in a form of a metal plate. The magnetic field detector has an aerial shaped as a coil. The way the aeriels are located (Fig. 3) influences directional characteris-

tics of the receiver.

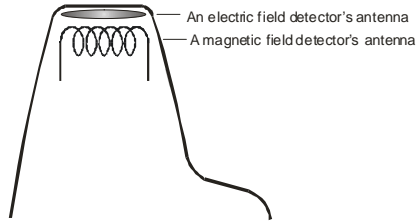

Fig.3 Location of sensors in receiver's antenna

Electric or magnetic field strength is indicated by the LED indicator **17** "deflection". Sensitivity of the receiver is set automatically. To increase instrument's precision, use the **16** **ZOOM** button. Pressing the button causes amplification of the LED gauge indications representing changes in the field's strength i.e. the range of changes that might be represented by only one or two LEDs being lit is now illustrated using the entire indication range of the gauge (more detailed description of this function can be found in section 7.1).

Receiver's work mode is switched sequentially using the **15** **MODE** button which is accompanied by LED **18** **E** or **19** **M** or **23** ⚡ being lit.

Two LEDs **22** **TRANSMITTER E** and **23** **TRANSMITTER M** indicate the currently used transmitter mode.

In the non-contact neon mode the receiver can detect if the tested line is live and can also locate a live cable. The receiver detects an electric field 50/60Hz displaying its strength on the LED gauge **17** and after exceeding certain level it turns on the **24** ⚡. In this mode the ZOOM function does not work.

5.4 Closed-Circuit Measurements

Measurements can be performed in a closed circuit provided that a current flow can be induced in the circuit. This is the case in a healthy line with line's voltage exceeding 9V (the circuit is closed by a transformer) and also in a shorted line, using the „M+E" mode or and external power source. In all described situations the detection is done by evaluating the magnetic component of the field. Fig.4 illustrates the direction of the magnetic field lines around the cable in which the modulated current flows, and the placement of the receiver allowing for the highest possible intensity of the received signal.

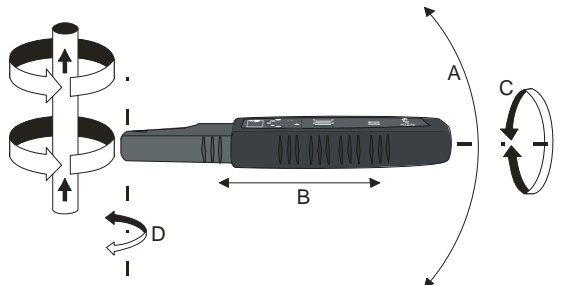

Fig.4 Magnetic field detection

Directional properties of the receiver can be observed when we try to change its position in relation to the cable in directions indicated by the arrows. Swinging the receiver only in directions "A" does not change the signal level since the magnetic field detector does not change its position in relation to the magnetic field lines. On the other hand, rotating the receiver around its axis (arrow "C") will cause gradual signal deterioration until it disappears when rotating the device by 90°. Similarly, when swinging the receiver in direction "D" (around the axis of the receiver's aerial). Also moving the receiver away from the cable ("B") will weaken the signal as a result of a decrease in field's strength with an increase of the distance.

For a 2-core cable in which the current flows through one of the cores in one direction and in the opposite direction through the other core, the magnetic field strength is much lower than in a single-core cable since the fields generated by the cores cancel each other out. The greater the distance between the cores, the stronger is the magnetic field. This phenomenon is utilised for detecting all sorts of inconsistencies in power lines e.g. cable boxes, switches, stub cables, cable ducts constrictions etc.

A different field distribution is created around a twisted pair cable. It is not uniform and changes periodically depending on the relative position of the cores (Fig. 5). It has to be taken into account when tracking a cable or locating cable faults.

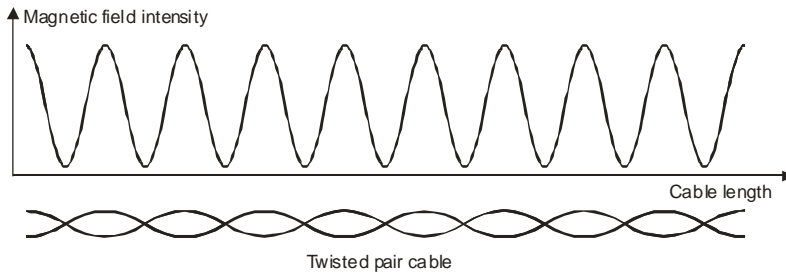

Fig.5 Magnetic field distribution around a twisted pair cable

5.5 Open-Circuit Measurements

Measurements in an open-circuit should be carried out if there is no way to force a current flow through the circuit. This is the case in a healthy long line that is not live, where using an external power source capable of generating sufficient current would be cumbersome or where the line is interrupted. In both cases the detection is through evaluation of the electric component of the field. Fig.6 illustrates the direction of the electric field lines around a live cable, and the placement of the receiver allowing for the highest possible intensity of the received signal.

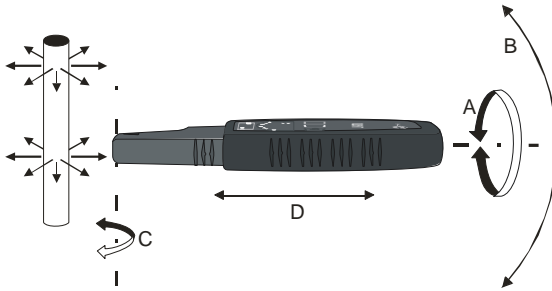

Fig.6 Electric field detection

Directional properties of the receiver can be observed when we try to change its position in relation to the cable in directions indicated by the arrows. Rotating the receiver around its own axis ("A") does not change the signal's strength since the electric field sensor will not change its position in relation to the electric field lines. On the other hand, swinging the receiver as indicated by "B" and "C" (around the axis of the receiver's aerial) and also in other directions will cause gradual signal deterioration until it disappears when the field lines and surface of the receiver are on planes that are parallel to each other. Also moving the receiver away from the cable ("D") will weaken the signal as a result of a decrease in field's strength with an increase of the distance.

In an open-circuit mode the line powered by the transmitter functions as an aerial and the earth becomes a reference potential.

6 Work Modes

6.1 General Information

The equipment can work in one of three modes: a current ("M") mode, a voltage („E") mode and a current-voltage („M+E") mode. In the „AUTO" mode the receiver automatically selects a mode in accordance with conditions that exist in the tested line.

Button **15**  of the receiver is used to change the work mode i.e. a voltage channel (using the electric field sensor) or a current channel (using the electric field sensor) is selected or the device is switched into a non-contact neon mode. In a majority of cases the voltage channel is activated for the transmitter working in a voltage mode and the current channel is activated for the transmitter working in the current or current-voltage mode. However, in some circumstances the stronger field is not necessarily the one that would be suggested by the transmitter's work mode. Therefore a selection can be made.

6.2 "M" Mode

"M" mode is used when working with healthy live cables with the connected voltage not less than 9V.

NOTE!

The transmitter is designed to work with the rated voltage of 230/400V. Connecting the device to a voltage that exceeds 500VAC can damage the instrument.

One of the transmitter's output terminals is connected to the phase wire of the tested cable and the other one to the neutral wire. The voltage that exists in this circuit is used by the transmitter to generate a current signal (max 40mA) in a form of high frequency impulses with the amplitude modulated by a lower frequency signal distributed over the time in the way that is specific for the current mode. The magnetic component of the field generated in this way is then detected by the receiver.

6.3 „E” Mode

“E” mode is used in dead cables where no closed circuit can be established (e.g. a break in the cable).

One of the output terminals of the transmitter is connected to the tested cable and the other to the earth. The transmitter generates a voltage signal in a form of high frequency impulses with the amplitude modulated by a lower frequency signal distributed over the time in a way that is specific for the voltage mode. The electric field generated in this way is then detected by the receiver.

6.4 „M+E” Mode

„M+E” mode is used in dead cables where a closed circuit can be established (e.g. dead healthy cable, shorted circuit).

One of the output terminals of the transmitter is connected to the phase wire of the tested circuit and the other one to the neutral wire. Using its own power supply the transmitter generates a current signal (max 40mA) in a form of high frequency impulses with the amplitude modulated by a lower frequency signal distributed over the time in the way that is specific for the current-voltage mode. The magnetic component of the field generated in this way is then detected by the receiver.

6.5 “AUTO” Mode

In “AUTO” mode the transmitter examines the conditions that exist in the tested line and selects a mode accordingly:

- If a voltage exceeding 9VAC is detected, a current mode is selected
- If no voltage is detected or the voltage detected is lower than 9VAC and there is a possibility to force a current flow, a current-voltage mode is selected
- If there is no voltage detected or the voltage is below 9VAC and there is no way to force a current flow, a voltage mode is selected

Note:

In an “AUTO” mode the AUTO LED and LED(s) corresponding to the mode selected by the transmitter are on.

Note:



If receivers are connected to a tested dead line, then the transmitter in "AUTO" can select the „M+E" mode. To work in the „E" mode you need to activate it manually by pressing the **4**  button or to disconnect all receivers from the tested line.

6.6 „E" ("Power") Mode

LKZ-700 can also work in a "power" „E" mode. In this configuration the transmitter in „E" mode is connected to a dead closed circuit. The current drained from the transmitter is then much higher than in the „M" mode using maximum power ($I_T > 1A$ for $R=0\Omega$ i.e. short circuit). It allows a significant increase of the detection range. In the receiver the „M" mode should be selected with the voltage signal identified as the transmitted signal (LED **22** TRANSMITTER E on).

This mode is especially recommended for the location of underground cable routes.

6.7 Audible signalization of field intensity

Receiver has possibility of emitting modular audible signal with frequency directly proportional to signal level, which additionally is displayed on the rough scale. To switch off or switch on audible signalization press button **15**  and **16**  while keeping power button.

7 Measurements

NOTE!

The transmitter is designed to work with the rated voltage of 230/400V. Connecting the device to a voltage that exceeds 500VAC can damage the instrument.

WARNING:

You must not leave one lead disconnected from the device while the other one is connected to the tested installation.
You must not leave the device connected to tested installation without supervision.

WARNING:

Always connect the transmitter to the ground first and only than to the phase wire.

Note:

In objects with working appliances, the receiver may display a level of noise signals. You should take into account the signal level only if one of LEDs **22** TRANSMITTER E or **23** TRANSMITTER M is on.

Note:

You have to recon with incorrect readings due to:



- Induction of current signals in closed circuits in buildings (window frames, metal framework, concrete reinforcements etc.)
- Electric field being induced in metal objects that are not earthed (not connected electrical installation, not earthed water mains, reinforcement bars etc.)

Note:

Take into account the influence of the transmitter on the sensitive receiver:

- in voltage mode "E" and in current-voltage mode "M" + "E", the signal generated in the transmitter passes through a transformer. Therefore using the receiver within the distance of 1.3 m from the transmitter may cause incorrect indications,
- in current-voltage mode "M"+"E" (additionally) when the circuit is not closed, the current will not flow and the alternating voltage that should generate this current will result in electric field detectable for the receiver,
- in both of the above modes, at greater distances within the tested circuits, despite the fact that the tested circuit is open, it is possible that the receiver will be able to indicate a magnetic field due to the current flow caused by parasitic capacities of the environment.

7.1 ZOOM Function

Signal amplification in the receiver is done automatically. Therefore the signal level (field strength) with the ZOOM function switched off is shown approximately and localization is very rough. An accurate localization of a cable is only possible after activating the ZOOM function by pressing the **16**  key. After that a stronger glowing and flashing LED providing accurate reading is superimposed on the LED gauge. After the **16**  key is pressed, the flashing light is positioned in the middle of the LED gauge.



If the flashing LED on the gauge reaches the leftmost (weaker signal) or the rightmost (stronger signal) position, it automatically returns to the middle of the scale and a short audible signal is produced. It is equivalent to readjustment of the sensitivity sub range.

Note:

The rightmost LED on the gauge emits stronger light than the other LEDs to facilitate gauge reading in a bright external light.

7.2 Detection of Cables in Ceilings, Walls and Floors

7.2.1 Live Cables

- Turn the transmitter on by pressing the **3**  button.
- Set a desired transmitter's output signal by pressing the **5**  button.



Note:

If an RCD is installed in the tested circuit, a suitable output signal level should be selected to prevent the RCD from being triggered.

- Using the **4**  button select the „M” or “AUTO” mode.
- Connect the **1** or **2** socket of the transmitter to the earth.

Note:

To avoid the field compensation effect when the current flows through two cores of the cable in opposite directions, you need to use grounding (the earth or the neutral wire) situated in the remote power socket or to connect to earthed metal water pipe or to a heating pipeline (Fig. 7). In some cases, e.g. when the return current can flow through earthed structural elements of the building, it can be more beneficial for unambiguous localization of the cable to connect both sockets of the transmitter to one power point.

- Connect the second socket to the phase wire in a power point, switch etc. (Fig. 7).
- After connecting the transmitter the **9** „OUTPUT OK” LED should light up.
- Turn the receiver on by pressing the **14**  button.
- Select the „M” mode by pressing the **15**  button.
- Move the receiver's antenna along the tested line (Fig.4) trying to follow the maximum strength of the signal. Press the **16**  button to increase the precision (section 7.1).

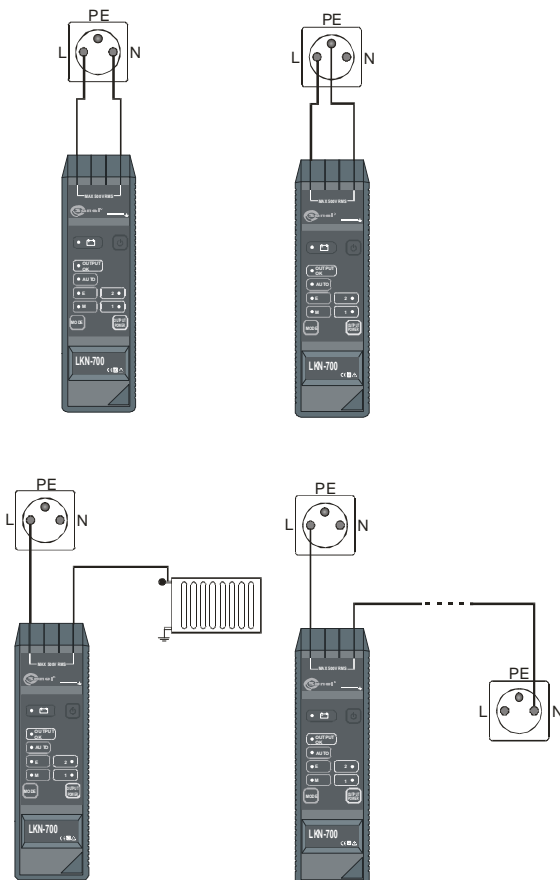







Fig.7 Detection of cables – different ways of connecting the transmitter

7.2.2 Dead Cables

WARNING:

Before a measurement check if the cables are live. If yes then cut off the power.

- Turn the transmitter on by pressing the **3**  Button.
- Set a desired transmitter's output signal by pressing the **5**  button.
- Using the **4**  button select the „E” or “AUTO” mode. The **9** „OUTPUT OK” LED should light up.
- Connect the **1** or **2** socket of the transmitter to the earth
- Connect the second socket to the phase wire in a power point, switch etc. (Fig. 8).

- Turn the receiver on by pressing the **14**  button.
- Select the „M” mode by pressing the **15**  button.
- Move the receiver's antenna along the tested line (Fig.6) trying to follow the maximum strength of the signal. Press the **16**  button to increase the precision (section 7.1).

Note:
You have to reckon with a reduction of the field strength due to the shielding effect of the earthed cores in the cable. For a twisted pair cable the distribution of the field strength will be similar to a magnetic field distribution in a live line (Fig.5).

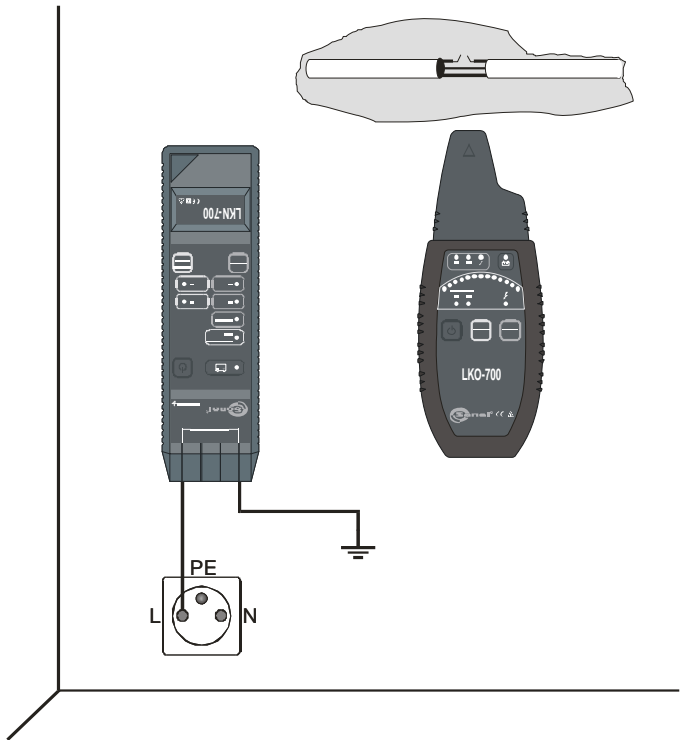

Fig.8 Localization of conductors and breaks in cables

7.2.3 Using „M+E” and “Power” „E” modes

Both modes can be used without a need to disconnect the power, provided that the transmitter is connected to both ends of the same cable (no voltage on transmitter's terminals). Using the “power” mode a much stronger signal than in the „M+E” mode will be received. Keep in mind that in this mode the receiver should be set to “I” mode. The transmitter should be connected between both ends of the tested cable using an extension cord if needed. En example is

shown in Fig. 9. Other procedures as in section 7.2.1.

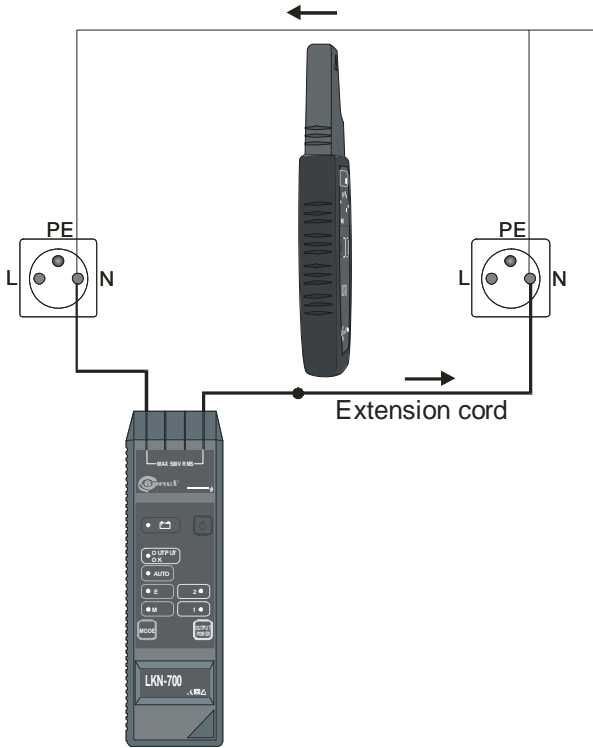

Fig.9 Localizing cables using „M+E” and “power” „E” modes



7.3 Locating Breaks in Cables

Note:

When testing multi-cable lines make sure that all cables that are not tested are earthed – preferably on both ends since the signals generated by the transmitter can propagate using capacitance between the cables which can prevent detection of cable breaks. It is also necessary to ground the other (not connected) end of the broken cable.

The procedure is the same as described in section 7.2.2. The signal disappears in the location of the fault.

7.4 Tracing of the Entire Building Installation.

- Isolate the external power at the junction box.
- Turn the transmitter on by pressing the **3**  key.
- Set a desired transmitter's output signal by pressing the **5**  button.

- Using the **4** **MODE** button select the „E” or “AUTO” mode. The **9** „OUTPUT OK” LED should light up.
- Connect the **1** or **2** socket of the transmitter to the disconnected PE wire and the other one to the earth terminal
- Turn the receiver on by pressing the **14** **⏻** button.
- Select the „E” mode by pressing the **15** **MODE** button.
- Move the receiver’s antenna along the tested line (Fig.6) trying to follow the maximum strength of the signal. Press the **16** **ZOOM** button to increase the precision (section 7.1).

7.5 Locating Power Points and Switches in Buildings



WARNING:

Disconnecting the PE wire is hazardous for the operator and other bystanders. Before the test check if tested cables are not live and if they are they must be disconnected. If possible, disconnect also the phase wire. Ensure that there are no bystanders in the danger zone. After finishing the task you must restore the PE or N wire connection.

- Disconnect all neutral and ground wires at the internal distribution board.
- Turn the transmitter on by pressing the **3** **⏻** key.
- Set a desired transmitter’s output signal by pressing the **5** **OUTPUT POWER** button.
- Using the **4** **MODE** button select the „E” or “AUTO” mode.
- Connect one of **1** or **2** sockets of the transmitter to the PE wire of the main power cable and the other one to the phase wire.
- After connecting the transmitter the **9** „OUTPUT OK” LED should light up
- Turn the receiver on by pressing the **14** **⏻** button.
- Select the „E” mode by pressing the **15** **MODE** button.
- To find a hidden power point (switch) move the receiver’s antenna along the tested line (Fig.6) trying to follow the maximum strength of the signal. Press the **16** **ZOOM** button to increase the precision (section 7.1). The element that is being searched for is located where the signal disappears.
- To find power points (switches) connected to a particular phase, bring receiver’s antenna close to the object checking the signal’s presence or otherwise. Press the **16** **ZOOM** button to increase the precision of reading (section 7.1).

7.6 Identification of Fuses on the Distribution Board

- Turn the transmitter on by pressing the **3** **⏻** key.
- Set a desired transmitter’s output signal by pressing the **5** **OUTPUT POWER** button.
- Using the **4** **MODE** button select the „M” or “AUTO” mode.
- Connect one of **1** or **2** sockets of the transmitter to the neutral wire of the power point and the other one to the phase wire.
- After connecting the transmitter the **9** „OUTPUT OK” LED should light up

- Turn the receiver on by pressing the **14**  button.
- Select the „M” mode by pressing the **15**  button.
- Moving the receiver's antenna from one fuse to another and using the **16**  button (section 7.1) locate the fuse you are looking for based on the maximum strength of the received signal (Fig.10).

Note:

Because modern fuses, and in particular RCDs, have inside one or more coils it may be necessary to try different ways of positioning the receiver and a number of attempts to locate a fuse will be required.

Note:

Identification can be difficult in the case of switchgears with many protections and supply leads.

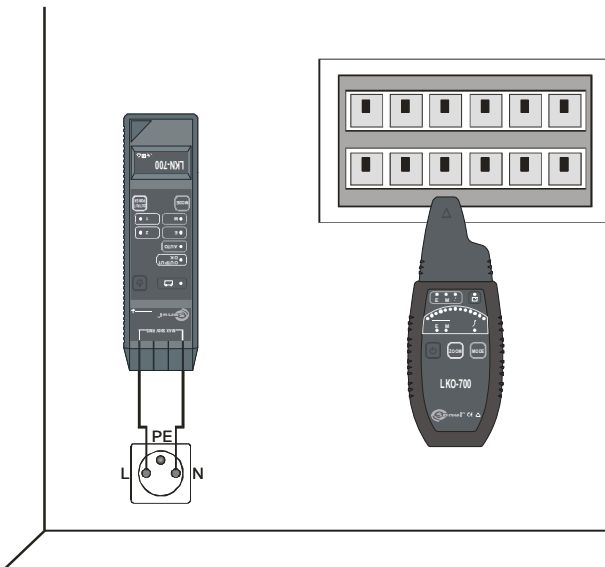







Fig.10 Identification of circuit breakers in a distribution board

7.7 Locating Short Circuits between Leads

WARNING:

Before a measurement check if the cables are live. If yes then cut off the power.

- Turn the transmitter on by pressing the **3**  key.

- Set a desired transmitter's output signal by pressing the **5**  button.
- Using the **4**  button select the current-voltage „M+E” or “AUTO” mode (Fig. 11a) or the “M” mode if an external power source is being used (Fig. 11b).
- Connect one of **1** or **2** sockets of the transmitter to shorted wires
- After connecting the transmitter the **9** „OUTPUT OK” LED should light up
- Turn the receiver on by pressing the **14**  button.
- Select the „M” mode by pressing the **15**  button.
- Move the receiver's antenna along the tested line (Fig. 4) following the maximum strength of the received signal. Using the **16**  button (section 7.1) increase the search precision (section 7.1). Starting from the spot where the short circuit is located the signal will decrease or disappear.

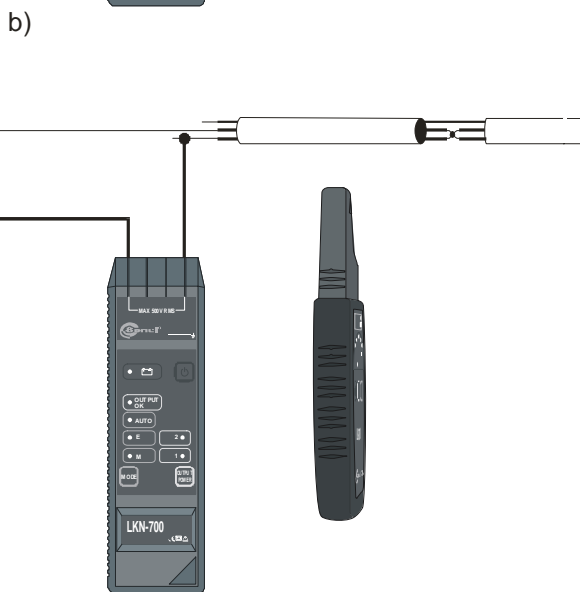

Fig.11 Locating a short circuit in a cable

Note:

With a high resistance of the circuit, transmitter's power supply voltage may be insufficient to provide adequate current: 10mA, 20mA or 40mA (LED 9 „OUTPUT OK” is off). In such situation you need to connect between the transmitter and one of the leads an additional power source providing satisfactory voltage (Fig.11b) and change transmitter's mode to “M”. In the diagram Fig.11a you can use the “power” remembering to set receiver's mode to current “M”.

Note:

For increased accuracy of the short circuit localization the test should be repeated starting from the other end of the cable.
When locating a short circuit point in a twisted pair cable you need to take into account heterogenous field distribution along the cable (Fig.5).

Note:

Because of the strong reciprocal suppression of signals in shorted wires, the location of short between leads in underground cables is very difficult or impossible.

7.8 Locating Underground Dead Cables (Not in Use)

Note:

LKZ-700 is intended mainly for locating electrical wiring in buildings. It can be also useful for detecting underground cables. In situations when it is difficult or impossible, a specialised detector for underground cables should be used.

In a closed circuit.

WARNING:

Disconnecting the protective wire is hazardous for the operator and for other bystanders. Special caution should be used when disconnecting the protective wire or the earthing of the neutral wire from the installation and the cable must be checked if it is not live. Ensure that there are no bystanders in the danger zone. After completing the task you must restore the PE or N wire connection.

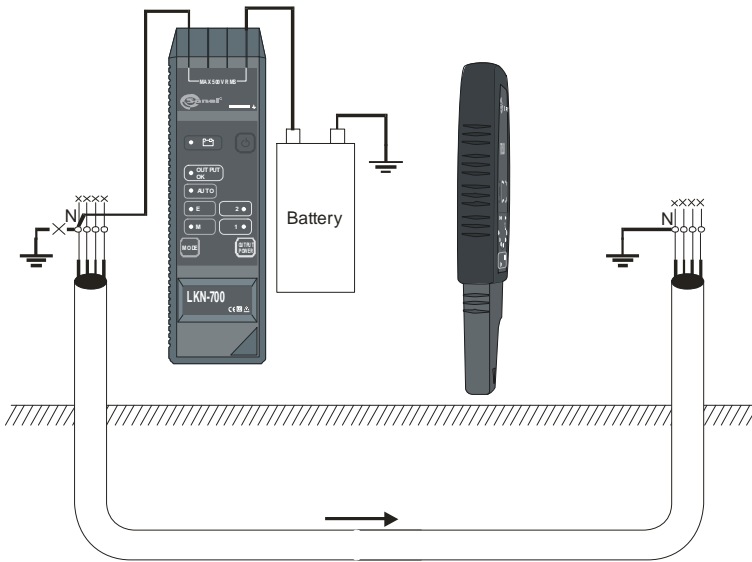







Fig.12 Locating unused underground cables using an additional voltage source

- Disconnect the protective (neutral) wire at the power distribution board and earth its other end.
- Turn the transmitter on by pressing the **3**  key.
- Set a desired transmitter's output signal by pressing the **5**  button.
- Using the **4**  button select the current „M” or “AUTO” mode. Use an additional voltage source.
- Connect transmitter's socket **1** or **2** to the ground, it can be the earthed frame of the distribution board, and the second socket to the disconnected neutral (protective) wire with a serially connected additional source of voltage.
- After connecting the transmitter the **9** „OUTPUT OK” LED should light up.
- Turn the receiver on by pressing the **14**  button.
- Select the „M” mode by pressing the **15**  button.
- Move the receiver's antenna along the tested line (Fig. 4) following the maximum strength of the received signal. Using the **16**  button (section 7.1) increase the search precision (section 7.1).

If the earth resistance is sufficiently low for a suitable current to be forced by receiver's internal power supply, the „M+E” mode or “power” „E” mode can be used. The transmitter should be then connected in the way shown in Fig.13.

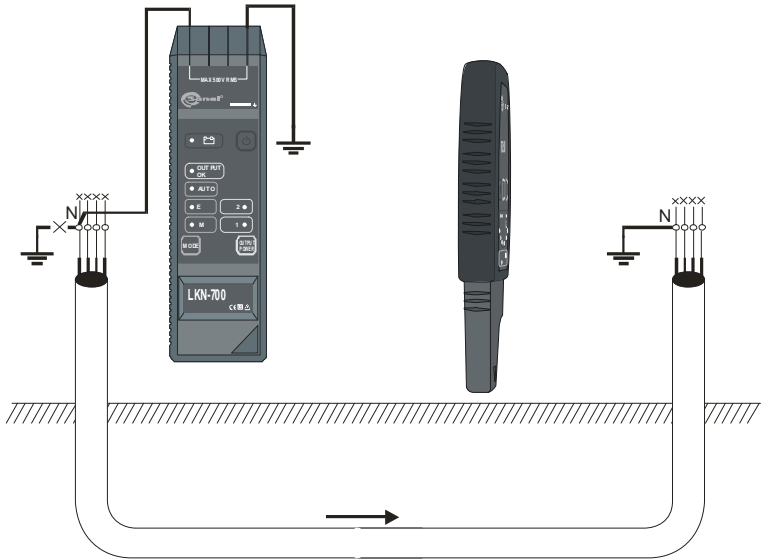

Fig.13 Locating unused underground cables using transmitter's internal power supply

If the resistance between earths is too high for a suitable transmitter's current to be forced (Fig.13) use the "power" „E" mode (the receiver works in the current mode) and connect the transmitter to the cores of the cable that are shorted at the other end (Fig.14). In this mode received signals are several times stronger than in the „M+E" mode in the same configuration.

If it is possible to use one external cable instead of one of the wires in the tested cable (Fig.15), the signal will be strengthened even more.

Note:

The method shown in Fig. 15 can be used in live cables if they cannot be disconnected.

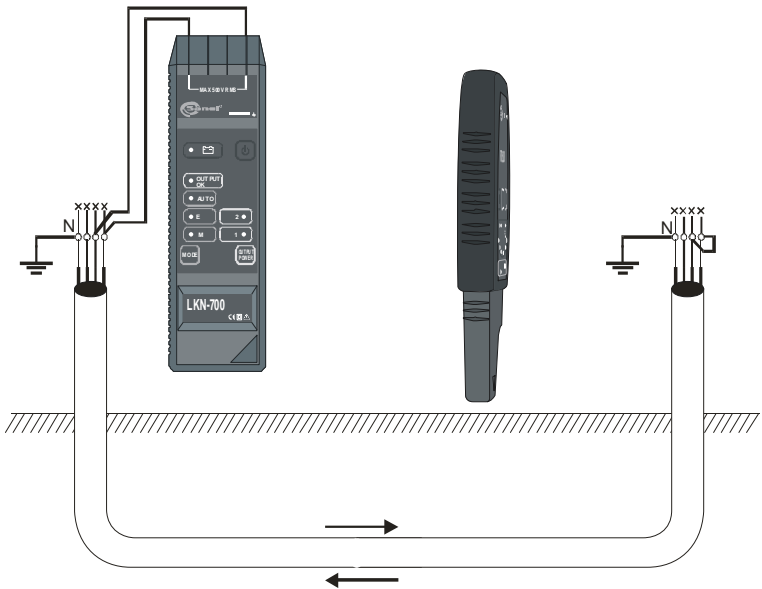

Fig.14 Locating unused underground cables using transmitter's internal power supply and with the cores shorted

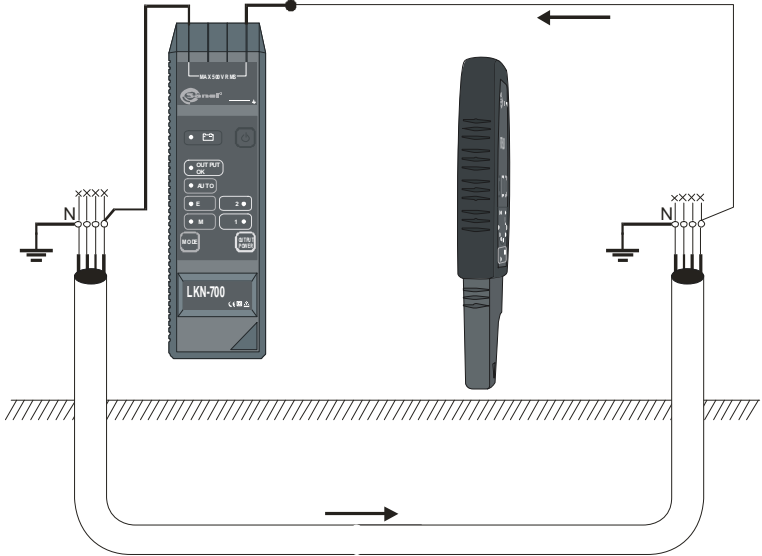







Fig.15 Locating unused underground cables using transmitter's internal power supply and an external wire

In an open circuit.

WARNING:

You have to check if the cable is not live. Ensure that there are no bystanders in the danger zone.

- Disconnect the phase wire at the power distribution board (Fig.16).
- Disconnect the neutral and protective wires earthing.
- Turn the transmitter on by pressing the **3**  key.
- Set a desired transmitter's output signal by pressing the **5**  button.
- Using the **4**  button select the voltage "E" or "AUTO" mode. the **9** „OUTPUT OK" LED should light up.
- Connect transmitter's socket **1** or **2** to the ground and the other one to the disconnected phase wire.
- Turn the receiver on by pressing the **14**  button.
- Select the „E" mode by pressing the **15**  button.
- Move the receiver's antenna along the tested line (Fig. 6) following the maximum strength of the received signal. Using the **16**  button increase the search precision (section 7.1).

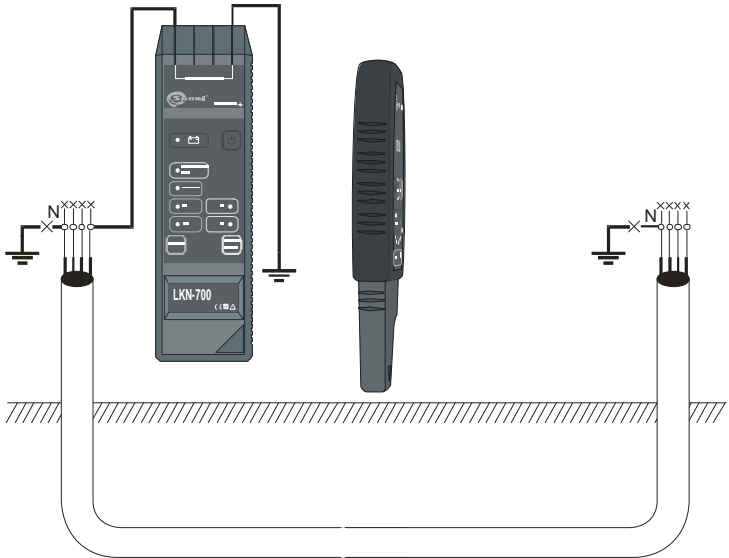





Fig.16 Locating unused underground cables in an open circuit

7.9 Tracing Shielded Cables

- Turn the transmitter on by pressing the **3**  key.
- Select the „M+E" mode using an external power source (as in section 7.7)
- Connect transmitter's socket **1** or **2** to the shield and the other one to the ground or to a grounded AC or DC voltage source (Fig. 17).

- Earth the other end of the shield
- After connecting the transmitter, the **9** „OUTPUT OK” LED should light up
- Turn the receiver on by pressing the **14**  button.
- Select the „M” mode by pressing the **15**  button.
- Move the receiver’s antenna along the tested line (Fig. 6) following the maximum strength of the received signal. Using the **16**  button increase the search precision (section 7.1).

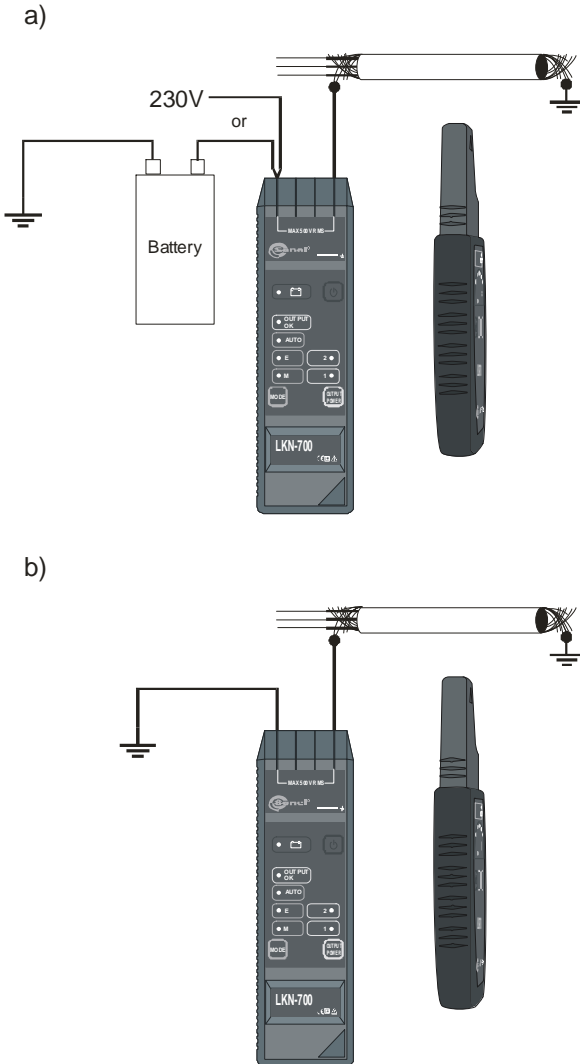

Fig.17 Tracing shielded cables routes: a) “M” mode, b) “M+E” mode

7.10 Tracing Cables in Metal Ducts

Procedure is the same as the one described in section 7.2. You only have to take into account that in steel ducts the signal is subject to attenuation. On the other hand aluminium and plastic ducts have no impact on the signal level.

7.11 Tracing Water Pipes and Heating Pipelines

7.11.1 Closed Circuit.

The procedure is the same as for locating cables in a closed circuit.

For earthed pipes you can use the „**M+E**” mode with connections shown in Fig.18 or the „**M**” mode with connections illustrated in Fig.19.

For pipes that are not earthed or when their earthing status is not known you can use the „**M+E**” mode with connections shown in Fig.20.

Ability to trace water pipes or heating pipelines is a side effect when searching for cables that utilise pipe work as earthing – the return current flows to the point where the transmitter is connected.

Note:
You need to take into account that the current flowing through a metal pipe to the earth will do so using all possible routes.

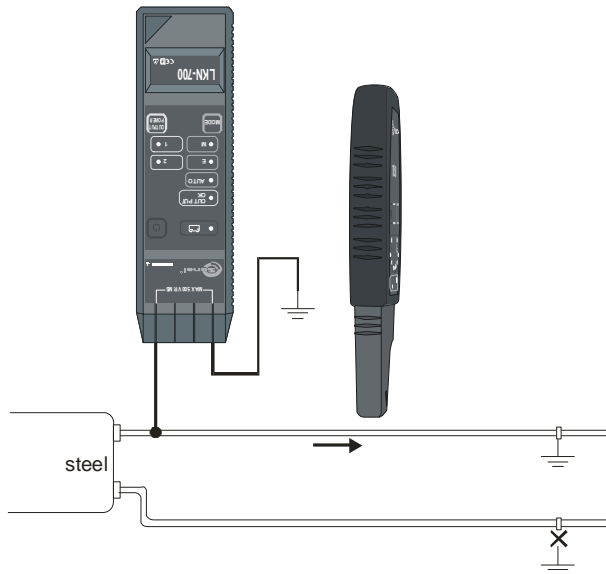

Fig.18 Tracing earthed pipes using „M+E” mode

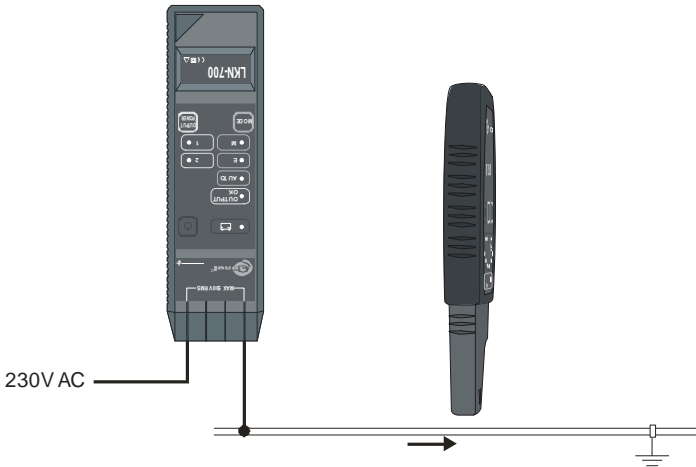

Fig.19 Tracing earthed pipes using “M” mode

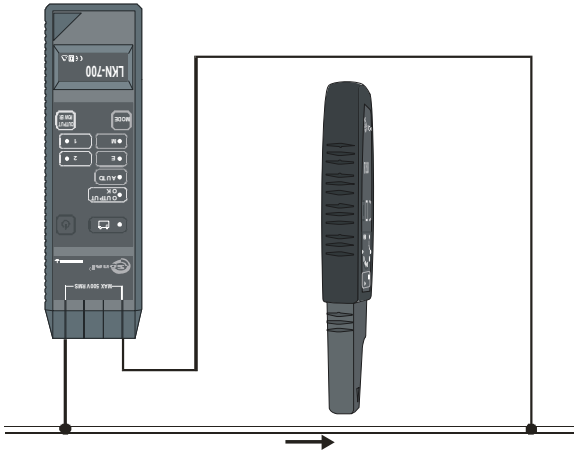





Fig.20 Tracing pipes that are not earthed using “M+E” mode

7.11.2 Open Circuit.

- Disconnect the earth connection from the pipeline.
- Turn the transmitter on by pressing the **3**  key.
- Set a desired transmitter's output signal by pressing the **5**  button.
- Using the **4**  button select the voltage “E” or “AUTO” mode
- Connect transmitter's socket **1** or **2** to the ground and the other one to tested pipeline.
- After connecting the transmitter, the **9** „OUTPUT OK” LED should light up
- Turn the receiver on by pressing the **14**  button.

- Select the „E” mode by pressing the **15** **MODE** button.
- Move the receiver's antenna along the pipeline (Fig. 6) following the maximum strength of the received signal. Using the **16** **ZOOM** button increase the search precision (section 7.1).

7.12 Investigating Channels and Holes Routings

Described locating methods can be used to investigate routings of channels and holes. A couple of examples are shown on the drawings below.

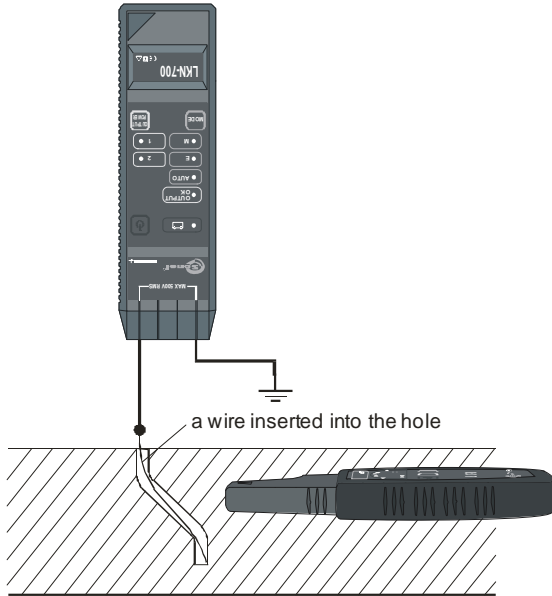

Fig.21 Investigating channels and holes routings using the “E” mode

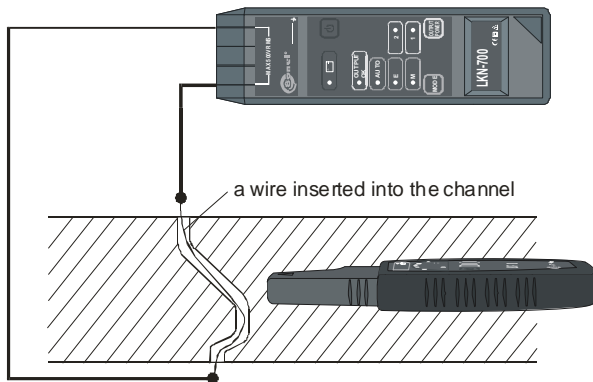



Fig.22 Investigating channels and holes routings using the „M+E” mode

8 Trouble Shooting

Transmitter automatically blocks signal broadcast if the batteries are discharged, which is signalled by a flashing LED .

If as a result of a self-test the transmitter discovers some irregularities, after a long audible signal that confirms completion of the auto-test and a 1s long pause, additional 2, 3 or 4 long signals identifying the problem will follow. In such situation switch the device off and then turn it on again. If the problem persists send the equipment to a service agent

LED  **OUTPUT OK** remaining off despite a correct selection of the work mode for the conditions in the tested circuit, indicates that the device is faulty.

9 Power Supply

9.1 Batteries

LKN-700 transmitter is equipped with a SONEL/NiMH 9,6V battery pack.

A need to recharge the battery pack is signalled by a flashing LED  with a frequency of :

- every 2,4 s when battery is discharged to the level 40...20 %
- every 1,2 s when battery is discharged to the level 20-0%
- every 0,4 s when battery is completely discharged and the broadcast is blocked.

9.1.1 Replacement of the Battery Pack

NOTE!

The battery pack can be replaced only by the manufacturer or an authorised service agent.

9.1.2 Charging the Battery Pack

A socket located under a cover on the bottom wall of the housing enables periodical recharging of the batteries without a need to remove them from the device. To recharge the batteries a charger supplied as a standard accessory is connected to the socket.

WARNING:

Before inserting the plug of working charger, disconnect the leads from the device.

NOTE!



To prevent a damage to the device and to ensure correct charging of the battery pack use only the charger that was supplied with the equipment.

To connect the charger:

1. Disconnect all cables and switch the transmitter off.
2. Remove the cover in the bottom part of the housing. Insert a thin screwdriver into the gap, press gently and slide the cover in the direction indicated by the arrow.
3. Insert the charger plug into the charger socket.
4. After charging is completed replace the cover.

Note:

For charging to be successful the ambient temperature must stay between 0 and +40°C.

Connecting the charger turns the device off (if it was turned on) and commences a charging cycle. During charging LEDs **6** M, **7** E, **8** AUTO, **9** OUTPUT OK, **12**  are being lit sequentially. Each LED is on for 0.3s. If the batteries voltage is below 6.5V, the batteries have to be preconditioned before the actual charging commences. During this stage each LED is on for 1s. If the batteries voltage is higher than 11.6V charging does not get activated and the LED **12**  flashes like after a successful recharge. After charging is completed the LED **12**  flashes in a 0.5s/1s cycle. Other flashing LEDs provide additional information:

9 OUTPUT OK – charging completed successfully

8 AUTO – charging completed after a time interval elapsed

7 E – charging completed after too high battery voltage detected

Additionally the transmitter signals charging irregularities by flashing the **11** **2** LED at a rate of 5 flashes per second. At the same time LEDs from **6** M to **9** OUTPUT OK display the error code. If such situation reoccurs contact a service agent.

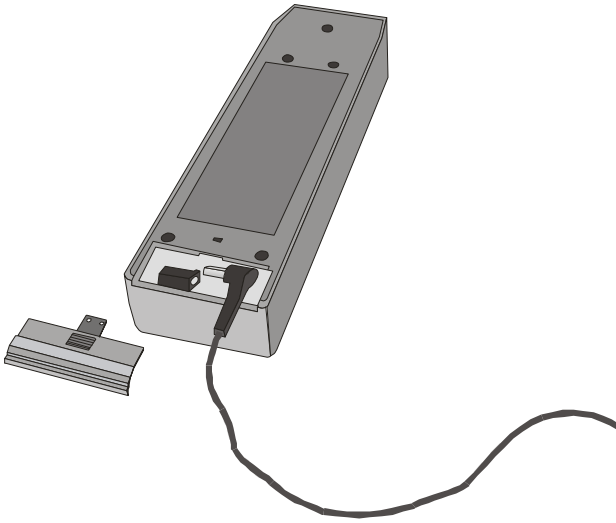

Fig.23. Connecting the battery charger.

9.1.3 General principles of using nickel metal hydride (Ni-MH) accumulators

- If the device is not used for a prolonged period of time, remove the accumulators and store them separately.

- Store accumulators in a dry, cool and well ventilated place, and protect them from direct sunlight. The storage temperature in the case of prolonged storage should be kept below 30°C. If accumulators are stored at a high temperature for a long time, then the chemical processes that are occurring may lead to reduction of their durability.

- NiMH accumulators are generally designed for 500-1000 charging cycles. The accumulators reach their maximum efficiency once they have been formed (after 2-3 charging and discharging cycles). The most important factor that influences the durability of those accumulators is the discharging depth. The deeper is the discharge, the shorter their durability.

- The memory effect in the case of NiMH accumulators is limited. Those accumulators may be additionally charged with no serious consequences. However, it is recommended to discharge them completely after a couple of cycles.

- During storage of Ni-MH accumulators, they are spontaneously discharged at the rate of approximately 30% per month. If accumulators are stored at high temperatures, the process may be accelerated as much as twofold. Lest the accumulators discharge excessively and to avoid the necessity of forming them, it is recommended to charge them from time to time (even if they are not used).

- Modern and fast chargers detect both too low and too high temperature of accumulators and react adequately. Too low a temperature should preclude charging, which might cause irreversible damage to the accumulator. An increase of the temperature of the accumulator is a signal to finish the process of charging and it is a normal phenomenon. However, charging at a high room temperature not only reduces durability, but also a faster increase of the temperature of the accumulator, which will be not charged to its full capacity.

- Please remember that in the case of fast charging, accumulators are charged to approximately 80% of their capacity and better results may be obtained continuing the process of charging: the charger operates then in the additional charging mode with low current and after next couple of hours the accumulators are fully charged.

- Do not charge or use accumulators at extreme temperatures. Extreme temperatures reduce the durability of batteries and accumulators. It is recommended to avoid placing devices powered from accumulators at hot places. The nominal working temperature must always be observed.

9.2 Replacement of Batteries in the Receiver

Receiver LKO-700 is powered from a 6F22 9V battery.

NOTE!

If a battery leaks inside the instrument, send the device to a service agent.

To replace the battery:

1. Turn the receiver off.
2. Remove the battery cover in the bottom part of the housing: press with your finger next to the latch and remove the cover sliding it in the direction indicated by the arrow.
3. Remove the battery.
4. Insert a new battery paying attention to correct orientation.
5. Replace the removed cover.

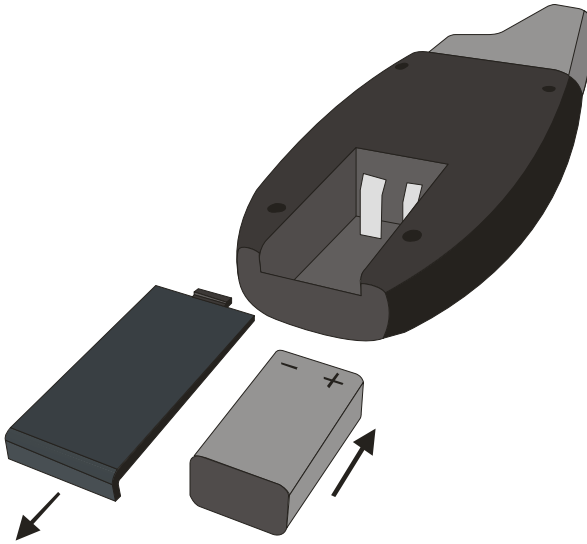

Fig.24. Replacement of the battery in the LKO-700 receiver

10 Cleaning and Maintenance

The housing of the meter should be cleaned with a soft, damp cloth using a general-purpose detergent. Do not use any solvents or any abrasive cleaning agents.

The electronic circuitry is maintenance free.

11 Storage

When storing the device you should:

- Disconnect all leads from the meter
- Ensure that the device and all accessories are dry
- Ensure that the batteries are removed if the device is not going to be used for a prolonged period of time
- Storage should conform to PN-85/T-06500/08 standard. Storage temperatures listed in the technical specification are acceptable

12 Decommissioning and Recycling

Decommissioned electrical equipment should be stored separately from other type of waste.

Decommissioned electrical equipment should be sent to an appropriate waste depot in compliance with legal acts governing electronic waste management..

Do not disassemble the equipment before sending it to a waste depot. Follow local legislation regulating disposal of packaging and batteries.

13 Appendices

13.1 Technical Specifications

- a) Type of insulation..... double, PN-EN 61010-1 compliant
- b) Metrological category.....III 600V in accordance with PN-EN 61010-1
- c) Tightness (transmitter and receiver) in accordance with PN-EN 60529
..... IP40
- d) Transmitter's power supply..... battery pack SONE/LNiMH 9.6V 2Ah
- e) Battery charging time.....aprox.10h,max13h
- f) Receiver's power supply battery 6LR61 9V alkaline
- g) Transmitter's max working voltage..... 500Vrms (707V_{amp})
- h) Transmitter's dimensions..... 230 x 67 x 36 mm
- i) Transmitter's mass..... ok. 490 g
- j) Receiver's dimensions 210 x 82 x 24 mm
- k) Receiver's mass..... ok. 200 g
- l) Working temperature..... -20..+50°C
- m) Storage temperature.....-20..+60°C
- n) Nominal temperature.....+20..+25°C
- o) Battery charging temperature..... 0..+40°C
- p) Receiver auto-off time.....10min
- q) Detector's max range („M" mode)..... 2m
- r) Non-contact neon max range:
 - In air 0.2m
 - In concrete 0.03m
- s) Quality standards design and manufacturing ISO 9001 compliant
- t) the product meets EMC requirements (immunity for industrial environment) according to the following standards.....EN 61326-1:2006 and EN 61326-2-2:2006

Note:

The transmitter can produce interference with the values exceeding the acceptable levels given in the PN-EN 61326-1 standard; in case of connection to the power network it can cause interference in other equipment.

13.2 Standard Accessories

Standard accessories comprise:

- Transmitter LKN-700 – **WMPLLN700**
- Receiver LKO-700 – **WMPLLK0700**
- Test lead with banana plug 1,2m ,black – **WAPRZ1x2BLBB**
- Test lead with banana plug 1,2m yellow – **WAPRZ1x2YEBB**
- Test lead on a reel with banana plugs: 20m,red – **WAPRZ020REBBSZ**
- Pin probe with banana connector black – **WASONBLOGB1**
- Pin probe with banana connector yellow – **WASONYEOGB1**
- Crocodile clip K01; black – **WAKROBL20K01**
- Crocodile clip K02; yellow – **WAKROYE20K02**
- Earth contact test probe (rod);0,26cm – **WASONG26**
- Carrying case M6 – **WAFUTM6**
- Ni-Mh battery package 9,6 V2Ah (inside the transmitter) – **WAAKU04**
- Battery charger – **WAZAS3x5Z1**

- Operating manual
- Battery 6F22

13.3 Optional Accessories

You can purchase the following optional accessories from the manufacturer or the distributors:

- Test probe 80cm for driving into the ground – **WASONG80**

13.4 The Manufacturer

The manufacturer of the device provides all warranty and after-warranty repairs:

SONEL S.A.
ul. Wokulskiego 11
58-100 Świdnica
Poland
tel. +48 74 858 38 60
fax +48 74 858 38 09
E-mail: export@sonel.pl
Web page: www.sonel.pl

Note:
Only the manufacturer is authorised to do any repairs.



MPI-525
Multifunction Electrical
Installations Meter



MPI-505
Multifunction
Electrical
Installations
Meter



MPI-502
Multifunction
Electrical
Installations
Meter



MRU-200
Earth Resistance
and Resistivity Meter



MRU-20
Earth
Resistance
and
Resistivity
Meter



MIC-2510
Insulation
Resistance
Meter



MIC-2
Insulation
Resistance
Meter



KT-384
Thermal
imager



MIC-30
Insulation
Resistance
Meter

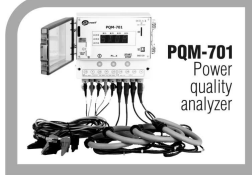

PQM-701
Power
quality
analyzer



LXP-1
Datalogging
Light
Meter



PAT-805
Portable
appliance
tester



CMM-40
Industrial
multimeter



CMP-1006
Digital
Clamp-on
multimeter



MMR-630
Microohmmeters



CMP-200
Digital
Clamp-on
AC



DIT-500
IR thermometer



LKZ-700
Wire tracer



SONEL S.A.
Wokulskiego 11, St
58-100 Swidnica
Poland



+48 74 85 83 860
+48 74 85 83 800
fax +48 74 85 83 808

<http://www.sonel.pl>
e-mail: export@sonel.pl